

ABB drives for HVAC

Quick installation and start-up guide

ACH580-01 drives

Frames R6 to R9

R6-
R9



EN

DA

DE

ES

FI

FR

IT

NL

PL

PT

RU

SV

TR

ZH

Power and productivity
for a better world™



List of related manuals in English

Drive manuals and guides

Code (English)

<i>ACH580 HVAC control program firmware manual</i>	3AXD50000027537
<i>ACH580-01 (0.75 to 250 kW) hardware manual</i>	3AUA0000076331
<i>ACH580-01 quick installation and start-up guide for frames R0 to R5</i>	3AUA0000076330
<i>ACH580-01 quick installation and start-up guide for frames R6 to R9</i>	3AXD50000036602
<i>ACS-AP-x assistant control panels user's manual</i>	3AUA0000085685

Option manuals and guides

<i>CDPI-01 communication adapter module user's manual</i>	3AXD50000009929
<i>DPMP-01 mounting platform for ACS-AP control panel</i>	3AUA0000100140
<i>DPMP-02/03 mounting platform for ACS-AP control panel</i>	3AUA0000136205
<i>FBIP-21 BACnet/IP adapter module</i>	3AXD50000028468
<i>FCAN-01 CANopen adapter module user's manual</i>	3AFE68615500
<i>FCNA-01 ControlNet adapter module user's manual</i>	3AUA0000141650
<i>FDNA-01 DeviceNet™ adapter module user's manual</i>	3AFE68573360
<i>FECA-01 EtherCAT adapter module user's manual</i>	3AUA0000068940
<i>FENA-01/-11/-21 Ethernet adapter module user's manual</i>	3AUA0000093568
<i>FEPL-02 Ethernet POWERLINK adapter module user's manual</i>	3AUA0000123527
<i>FLON-01 LonWORKS® adapter module user's manual</i>	3AUA0000041017
<i>FPBA-01 PROFIBUS DP adapter module user's manual</i>	3AFE68573271
<i>FSCA-01 RS-485 adapter module user's manual</i>	3AUA0000109533
<i>Flange mounting quick guide for frames R6 to R9</i>	3AXD50000019099
<i>Flange mounting supplement</i>	3AXD50000019100

Tool and maintenance manuals and guides

<i>Drive composer PC tool user's manual</i>	3AUA0000094606
<i>Converter module capacitor reforming instructions</i>	3BFE64059629
<i>NETA-21 remote monitoring tool user's manual</i>	3AUA00000969391
<i>NETA-21 remote monitoring tool installation and start-up guide</i>	3AUA0000096881

You can find manuals and other product documents in PDF format on the Internet. See section [Document library on the Internet](#) on the inside of the back cover. For manuals not available in the Document library, contact your local ABB representative.

The QR code below opens an online listing of the manuals applicable to this product.



3AXD50000036602 Rev A
MUL
EFFECTIVE: 2016-03-11

Table of contents

List of related manuals in English

Frames R6 to R9

Ratings and fuses

I	13
II	13
III	14
IV	14
V	14

EN – R6...R9 Quick installation guide

Obey the safety instructions	15
Check if capacitors need to be reformed	15
Select the power cables	16
Ensure the cooling	16
Protect the drive and input power cable	16
Install the drive on the wall	16
Check the insulation of the power cables and the motor	17
Check the compatibility with IT (ungrounded) and corner-grounded TN systems	17
EMC filter	17
Ground-to-phase varistor	17
Disconnect EMC filter or ground-to-phase varistor, if needed	19
Connect the power cables	20
Connect the control cables	21
Default I/O connections	22
Install optional modules, if any	23
Install side plates and covers	23

DA – R6...R9 Hurtig installationsvejledning

Overhold sikkerhedsinstruktionerne	25
Kontrollér, om det er nødvendigt at reformere kondensatorerne	25
Vælg effektkabler	26
Sørg for kølingen	26
Beskyt frekvensomformereren og netkablet	26
Installer frekvensomformereren på væggen	26
Kontrollér isoleringen på effektkablerne og motoren	27
Kontrollér kompatibiliteten med IT-net (ujordede) og hjørnejordede TN-net	27
EMC-filter	27
Jord til fase-varistor	27
Frakobl om nødvendigt EMC-filteret eller jord til fase-varistoren	29
Tilslut effektkablerne	30
Tilslutning af styrekablerne	31
I/O-standardtilslutninger	32

4 Table of contents

Installér valgfrie moduler, hvis de findes	33
Installér sideplader og dæksler	33

DE – R6...R9 Kurzanleitung für die Installation

Befolgen Sie die Sicherheitsvorschriften	35
Prüfen Sie, ob Kondensatoren nachformiert werden müssen	35
Auswahl der Leistungskabel	36
Ausreichende Kühlung sicherstellen	36
Schutz des Frequenzumrichters und der Eingangskabel	36
Wandmontage des Frequenzumrichters	36
Prüfung der Isolation der Einspeise- und Motorkabel und des Motors	37
Prüfung der Kompatibilität mit IT- (ungeerdeten) und asymmetrisch geerdeten TN-Netzen	37
EMV-Filter	37
Erde-Phase-Varistor	38
Trennen des EMV-Filters oder Erde-Phase-Varistors, falls erforderlich	39
Anschluss der Leistungskabel	40
Anschluss der Steuerkabel	41
Standard E/A-Anschlüsse	42
Installation optionaler Module, falls vorhanden	43
Installation der Seitenverkleidungen und Abdeckungen	43

ES – Guía rápida de instalación para bastidores R6...R9

Siga estrictamente las instrucciones de seguridad	45
Compruebe si es necesario reacondicionar los condensadores	45
Seleccione los cables de potencia	46
Garantice la refrigeración	46
Proteja el convertidor y el cable de potencia de entrada	46
Monte el convertidor de frecuencia en la pared	46
Compruebe el aislamiento de los cables de potencia y del propio motor	47
Compruebe la compatibilidad con las redes IT (sin conexión a tierra) y redes TN con conexión a tierra en un vértice	47
Filtro EMC	47
Varistor tierra-fase	47
Desconecte el filtro EMC o el varistor tierra-fase, si es necesario	49
Conecte los cables de potencia	50
Conecte los cables de control	51
Conexiones de I/O por defecto	52
Si tiene módulos opcionales, instálelos	53
Instale las cubiertas y las placas laterales	53

FI – R6...R9 Asennuksen pikaopas

Noudata turvaohjeita	55
Tarkista, täytyykö kondensaattorit elvyttää	55
Valitse tehokaapelit	56
Varmista jäähdytys	56
Suojaa taajuusmuuttaja ja syöttökaapeli	56
Asenna taajuusmuuttaja seinälle	56
Tarkista tehokaapelien ja moottorin eristys	57
Tarkista yhteensopivuuksia maadoittamattomien IT-verkkojen ja epäsymmetrisesti maadoitettujen TN-verkkojen kanssa	57

EMC-suodin	57
Maajohtimen ja vaihejohtimen välinen varistori	57
Kytke EMC-suodin tai maajohtimen ja vaihejohtimen välinen varistori tarvittaessa irti	59
Kytke tehokaapelit	60
Kytke ohjauskaapelit	61
Oletusarvoiset I/O-kytkennät	62
Asenna mahdolliset lisävarustemoduulit	63
Asenna sivulevyt ja kannet	63

FR – Guide d'installation R6...R9

Consignes de sécurité	65
Vérification des condensateurs	65
Sélection des câbles de puissance	66
Refroidissement	66
Protection du variateur et du câble réseau	66
Montage mural du variateur	66
Mesure de la résistance d'isolement des câbles de puissance et du moteur	67
Vérification de la compatibilité avec les réseaux en schéma IT (neutre isolé ou impédant) ou TN (mise à la terre asymétrique)	67
Filtre RFI	67
Varistance phase-terre	67
Déconnexion du filtre RFI ou de la varistance phase-terre si requis	69
Raccordement des câbles de puissance	70
Raccordement des câbles de commande	71
Raccordement des signaux d'E/S (préréglages)	72
Installation des modules optionnels (si présents)	73
Montage des capots et des plaques latérales	73

IT – Guida rapida all'installazione R6...R9

Rispettare le norme di sicurezza	75
Ricondizionamento dei condensatori	75
Selezione dei cavi di potenza	76
Raffreddamento	76
Protezione del convertitore e del cavo di alimentazione di ingresso	76
Montaggio del convertitore di frequenza a parete	76
Controllo dell'isolamento dei cavi di potenza e del cavo motore	77
Verifica della compatibilità con sistemi IT (senza messa a terra) e sistemi TN con una fase a terra	77
Filtro EMC	77
Varistore fase-terra	77
Scollegamento del filtro EMC o del varistore fase-terra (quando necessario)	79
Collegamento dei cavi di alimentazione	80
Collegamento dei cavi di controllo	81
Collegamenti di I/O di default	82
Installazione dei moduli opzionali, se presenti	83
Installazione di piastre laterali e coperchi	83

NL – R6...R9 Beknopte installatiegids

Volg de veiligheidsvoorschriften	85
Controleer of condensatoren opnieuw geformeerd moeten worden	85

6 Table of contents

Kies de vermogenskabels	86
Zorg voor de koeling	86
Beveilig de omvormer en de voedingskabel	86
Installeer de omvormer aan de wand	86
Controleer de isolatie van de vermogenskabels en de motor	87
Controleer de compatibiliteit met IT (ongearde) en hoekgeaarde TN systemen	87
EMC-filter	87
Aarde-naar-fase varistor	87
Ontkoppel, indien nodig, het EMC-filter of de aarde-naar-fase varistor	89
Sluit de vermogenskabels aan	90
Sluit de besturingskabels aan	91
Standaard I/O aansluitingen	92
Installeren van eventuele optionele modules	93
Installeer zijplaten en kappen	93

PL – Skrócona instrukcja montażu – obudowy R6...R9

Należy przestrzegać instrukcji bezpieczeństwa	95
Sprawdzenie, czy kondensatory wymagają formowania	95
Dobór kabli zasilania	96
Zapewnianie chłodzenia	96
Ochrona przemiennika częstotliwości i kabla zasilania wejściowego	96
Montaż przemiennika częstotliwości na ścianie	96
Sprawdzenie izolacji kabli zasilania i silnika	97
Sprawdzanie zgodności z sieciami IT (bez uziemienia) i sieciami TN (z uziemieniem wierzchołkowym)	97
Filtr EMC	97
Warystor uziemienie-faza	97
Odłączanie filtra EMC lub warystora uziemienie-faza, jeśli jest to wymagane	99
Podłączanie kabli zasilania	100
Podłączanie kabli sterowania	101
Domyślne połączenia we/wy	102
Instalacja ewentualnych modułów opcjonalnych	103
Montowanie płyt bocznych i osłon	103

PT – R6...R9 Guia de instalação rápida

Obedeça às instruções de segurança	105
Verifique se os capacitores precisam ser reformados	105
Selecione os cabos de força	106
Assegure que haja resfriamento	106
Proteja o inversor de frequência e o cabo de força de entrada	106
Instale o inversor de frequência na parede	106
Verifique o isolamento dos cabos de energia e do motor	107
Verifique se há compatibilidade com os sistemas de IT (sem aterramento) e TN com aterramento no vértice	107
Filtro EMC	107
Varistor terra-fase	107
Desconecte o filtro EMC ou varistor terra-fase, se necessário	109
Conecte os cabos de força	110
Conecte os cabos de controle	111
Conexões padrão de E/S	112

Instale módulos opcionais, caso haja algum	113
Instale as placas laterais e tampas	113

RU – Руководство по быстрому монтажу R6...R9

Следуйте указаниям по технике безопасности	115
Проверьте, не требуется ли формовка конденсаторов	115
Выберите силовые кабели	116
Обеспечьте надлежащее охлаждение	116
Защитите привод и входной силовой кабель от повреждений	116
Закрепите привод на стене	116
Проверьте сопротивление изоляции питающих кабелей и двигателя	117
Проверьте совместимость с системами ИТ (незаземленные сети) и системами TN с заземленной вершиной треугольника	117
ЭМС-фильтр	117
Варистор «земля-фаза»	118
При необходимости отключите ЭМС-фильтр или варистор «земля-фаза»	119
Подключите силовые кабели	120
Подключите кабели управления	121
Стандартные подключения входов/выходов	122
Установите дополнительные модули, если таковые имеются	123
Установите боковые панели и крышки	123

SV – R6...R9 Snabbguide för installation

Följ säkerhetsinstruktionerna	125
Kontrollera om kondensatorerna måste reformeras	125
Anslutning av kraftkablar	126
Kontrollera att kylningen är tillfredsställande	126
Skydda frekvensomriktaren och matningskabeln	126
Installera frekvensomriktaren på vägg	126
Kontrollera isolationen hos matningskablarna och motorn	127
Kontrollera kompatibilitet med IT-system (icke-direktjordade) och impedansjordade TN-system	127
EMC-filtret	127
Jord till fas-varistor	127
Koppla bort EMC-filtret eller jord till fas-varistorn vid behov	129
Anslut matningskablarna	130
Anslut styrkablarna	131
Förvalda I/O-anslutningar	132
Installera tillvalsmoduler, om det finns några	133
Installera sidoplattorna och kåporna	133

TR – R6...R9 Hızlı kurulum kılavuzu

Güvenlik talimatlarına uyun	135
Kondansatörlerin yenilenmesinin gerekip gerekmediğini kontrol edin	135
Güç kablolarını seçin	136
Soğutmayı sağlayın	136
Sürücüyü ve giriş güç kablosunu koruyun	136
Sürücüyü duvara kurun	136
Güç kablolarının ve motorun yalıtımını kontrol edin	137
İT (topraklamasız) ve TN sistemleriyle uyumluluğu kontrol edin	137

8 Table of contents

EMC filtresi	137
Toprak-faz varistörü	137
Gerekirse, EMC filtresinin veya toprak-faz varistörünün bağlantısını kesin	139
Güç kablolarını bağlayın	140
Kontrol kablolarını bağlayın	141
Varsayılan G/Ç bağlantıları	142
Varsa isteğe bağlı modülleri kurun	143
Yan plakaları ve kapakları takın	143

ZH – R6...R9 快速安装指南

遵循安全指导	145
检查电容是否需要重整	145
选择电缆	145
确保冷却	146
保护变频器和输入电缆	146
在墙上安装变频器	146
检查供电电缆和电机的绝缘	147
检查与 IT (浮地) 和角接地的 TN 系统的兼容性	147
EMC 滤波器	147
压敏电阻	147
断开 EMC 滤波器或压敏电阻 (必要时)	149
连接电缆	150
连接控制电缆	151
默认 I/O 连接	152
安装可选模块	153
安装侧板和盖板	153

Compliance with the European Machinery Directive 2006/42/EC

Declaration of conformity	155
---------------------------	-----

R6...R9 Figures A

B	157
C	157
D	158

R6...R9 Figures E

Quick start-up guide

EN – Quick start-up guide

Before you start	163
Start-up with the First start assistant on an HVAC control panel	163

DA – Vejledning til hurtig opstart

Inden du starter	169
Opstart ved hjælp af HVAC-betjeningspanelet og Første start-assistenten	169

DE – Kurzanleitung für die Inbetriebnahme

Vor Beginn der Arbeit	175
Erstinbetriebnahme mit dem Assistenten des HLK-Bedienpanels	175

ES – Guía rápida de puesta en marcha

Antes de empezar	181
Puesta en marcha con el Asistente de primera puesta en marcha con un panel de control HVAC	181

FI – Pika-aloitusopas

Ennen käynnistystä	187
Käynnistys HVAC-ohjauspaneelin 1. käynnistyksen assistentti -toiminnon avulla	187

FR – Guide de mise en route

Avant de commencer	193
Mise en route avec l'assistant de la micro-console HVAC	193

IT – Guida rapida all'avviamento

Prima di iniziare	199
Avviamento con la funzione di assistenza del pannello di controllo HVAC	199

NL – Beknopte opstartgids

Vóór het starten	205
Opstarten met de Eerste-start assistent op een HVAC bedieningspaneel	205

PL – Skrócona instrukcja uruchamiania

Przed rozpoczęciem	211
Uruchamianie przy użyciu Asystenta pierwszego uruchamiania na panelu sterowania HVAC	211

PT – Guia de início rápido

Antes de iniciar	217
Dando início ao assistente de inicialização no painel de controle HVAC	217

RU – Краткое руководство по вводу в эксплуатацию

Подготовительные операции	223
Запуск с помощью мастера первого запуска панели управления HVAC	223

SV – Snabbguide för idrifttagning

Innan du börjar	229
Idrifttagning med Upstartsassistenten på en HVAC-manöverpanel	229

TR – Hızlı başlatma kılavuzu

Başlamadan önce	235
HVAC kontrol panelinde İlk başlatma asistanıyla başlatma	235

ZH – 快速启动指南

启动之前 241
在 HVAC 控制盘上用“初次启动助手”启动 241

Further information

Product and service inquiries 247
Product training 247
Providing feedback on ABB Drives manuals 247
Document library on the Internet 247

Quick installation guide

ACH580-01 drives

Frames R6 to R9

R6-
R9



English	15	EN
Dansk	25	DA
Deutsch	35	DE
Español	45	ES
Suomi	55	FI
Français	65	FR
Italiano	75	IT
Nederlands	85	NL
Polski	95	PL
Português	105	PT
Русский	115	RU
Svenska	125	SV
Türkçe	135	TR
中文	145	ZH

3AXD50000036602 Rev A
MUL
EFFECTIVE: 2016-03-11

© 2016 ABB Oy. All Rights Reserved.

Ratings and fuses

I

ACH580 -01-	Input rating	Output ratings			Heat dissipation	Air flow	Frame size
		Nominal use					
	I_{1N}	I_{2N}	P_N	P_{Ld}			
	A	A	kW	kW			
3-phase $U_N = 400$ V (380...415 V)							
145A-4	145	145	75	75	1476	435	R6
169A-4	169	169	90	90	1976	450	R7
206A-4	206	206	110	110	2346	450	R7
246A-4	246	246	132	132	3336	550	R8
293A-4	293	293	160	160	3936	550	R8
363A-4	363	363	200	200	4836	1150	R9
430A-4	430	430	250	200	6036	1150	R9

3AXD00000586715.xls H

R6-
R9

II

ACH580 -01-	Input rating	Output ratings				Heat dissipation	Air flow	Frame size
		Nominal use		Heavy duty use				
	I_{1N}	I_{2Ld}	P_{Ld}	I_{2Hd}	P_{Hd}			
	A	A	hp	A	hp			
3-phase $U_N = 480$ V (440...480 V)								
145A-4	124	124	100	96	75	1476	256	R6
169A-4	156	156	125	124	100	1976	265	R7
206A-4	180	180	150	156	125	2346	265	R7
246A-4	240	240	200	180	150	3336	324	R8
293A-4	260	260	200	240*	150	3936	324	R8
363A-4	361	361	300	302	250	4836	677	R9
430A-4	414	414	350	361**	300	6036	677	R9

* 130% overload only

** 125% overload only

3AXD00000586715.xls H

III

ACH580 -01-	gG				Type IEC 60269
	I_N	I^2t	Voltage rating	ABB type	
	A	A ² s	V		
3-phase $U_N = 400/480$ V (380...415 V, 440...480 V)					
145A-4	160	185000	500	OFAF00H160	00
169A-4	250	600000	500	OFAF0H250	0
206A-4	315	710000	500	OFAF1H315	1
246A-4	355	920000	500	OFAF1H355	1
293A-4	425	1300000	500	OFAF2H425	2
363A-4	500	2000000	500	OFAF2H500	2
430A-4	600	2800000	500	OFAF3H630	3

3AXD00000586715.xls H

R6-
R9

IV

ACH580 -01-	uR or aR				Type IEC 60269
	I_N	I^2t	Voltage rating	Bussmann type	
	A	A ² s	V		
3-phase $U_N = 400/480$ V (380...415 V, 440...480 V)					
145A-4	250	28500	690	170M3816	1
169A-4	315	46500	690	170M3817	1
206A-4	350	68500	690	170M3818	1
246A-4	450	105000	690	170M5809	2
293A-4	500	145000	690	170M5810	2
363A-4	630	275000	690	170M5812	2
430A-4	700	405000	690	170M5813	2

3AXD00000586715.xls H

V

ACH580 -01-	UL			
	I_N	Voltage rating	Bussmann type	UL class
	A	V		
3-phase $U_N = 460$ V (440...480 V)				
145A-4	200	600	JJS-200	T
169A-4	225	600	JJS-225	T
206A-4	300	600	JJS-300	T
246A-4	350	600	JJS-350	T
293A-4	400	600	JJS-400	T
363A-4	500	600	JJS-500	T
430A-4	600	600	JJS-600	T

3AXD00000586715.xls H

EN – R6...R9 Quick installation guide

This guide briefly describes how to install the drive. For complete information on installation, see *ACH580-01 (0.75 to 250 kW) hardware manual* (3AUA0000076331 [English]). For start-up instructions, see chapter *EN – Quick start-up guide* on page 163.

To read a manual, go to www.abb.com/drives/documents and search for the document number.

R6-
R9

Obey the safety instructions



WARNING! Obey these instructions. If you ignore them, injury or death, or damage to the equipment can occur:

- If you are not a qualified electrician, do not do electrical installation work.
- Do not work on the drive, motor cable or motor when main power is applied. If the drive is already connected to the input power, wait for 5 minutes after disconnecting the input power.
- Do not work on the control cables when power is applied to the drive or to the external control circuits.
- Use the lifting eyes of the drive when you lift the drive. Do not tilt the drive. The drive is heavy and its center of gravity is high. An overturning drive can cause physical injury.
- Make sure that debris from borings and grindings does not enter the drive when installing.
- Make sure that the floor below the drive and the wall where the drive is installed are non-flammable.

EN

Check if capacitors need to be reformed

If the drive has not been powered (either in storage or unused) for over one year, you must reform the capacitors.

You can determine the manufacturing time from the serial number, which you find on the type designation label attached to the drive. The serial number is of format MYYWWRXXXX. YY and WW tell the manufacturing year and week as follows:

YY: 13, 14, 15, ... for 2013, 2014, 2015, ...

WW: 01, 02, 03, ... for week 1, week 2, week 3, ...

For information on reforming the capacitors, see *Converter module capacitor reforming instructions* (3BFE64059629 [English]), available on the Internet at www.abb.com/drives/documents.

Select the power cables

Size the power cables according to local regulations to carry the nominal current given on the type designation label of your drive.

R6-
R9

Ensure the cooling

See table I on page 13 (UL: table II on page 13) for the heat dissipation. The allowed operating temperature range of the drive is -15 to +50 °C (+5 to +122 °F). No condensation or frost is allowed. For more information on the ambient temperature and derating, see chapter *Technical data* in *ACH580-01 (0.75 to 250 kW) hardware manual* (3AJUA0000076331 [English]).

EN

Protect the drive and input power cable

See tables III, IV and V on pages 14 and 14 for the fuses.

If you use gG fuses, make sure that the operating time of the fuse is below 0.5 seconds. Follow the local regulations.

Install the drive on the wall

 **Warning!** The drive module is heavy (42 to 103 kg / 93 to 227 lb). Use a suitable lifting device. Do not lift the module manually. Make sure that the wall and the fixing devices can carry the weight.

See figure *R6...R9 Figures A* on page 157.

Check the insulation of the power cables and the motor

Check the insulation of the input cable according to local regulations before connecting it to the drive.

See figure **B** on page **157**.

1. Check the insulation of the motor cable and motor before connecting it to the drive. Measure the insulation resistance between each phase conductor and then between each phase conductor and the Protective Earth conductor using a measuring voltage of 1000 V DC. The insulation resistance of a typical motor must exceed 100 Mohm (reference value at 25 °C or 77 °F). For the insulation resistance of motors, see the manufacturer's instructions.

R6-
R9

Note: Moisture inside the motor casing will reduce the insulation resistance. If moisture is suspected, dry the motor and repeat the measurement.

EN

Check the compatibility with IT (ungrounded) and corner-grounded TN systems

■ EMC filter

The internal EMC filter is not suitable for use on an IT (ungrounded) system or on a corner-grounded TN system. Disconnect the EMC filter before connecting the drive to the supply network. Check the table on page **18**.



WARNING! Do not install the drive with the internal EMC filter connected on an IT system (an ungrounded power system or a high-resistance-grounded [over 30 ohms] power system), otherwise the system will be connected to ground potential through the EMC filter capacitors of the drive. This can cause danger, or damage the drive.

Do not install the drive with the internal EMC filter connected on a corner-grounded TN system, otherwise the drive will be damaged.

Note: When the internal EMC filter is disconnected, the drive EMC compatibility is considerably reduced.

■ Ground-to-phase varistor

The ground-to-phase varistor is not suitable for use on an IT (ungrounded) system. Disconnect the ground-to-phase varistor before connecting the drive to the supply network. Check the table on page **18**.

⚠ WARNING! Do not install the drive with the ground-to-phase varistor connected on an IT system (an ungrounded power system or a high-resistance-grounded [over 30 ohms] power system), otherwise the varistor circuit can be damaged.

Check from the table below if you have to disconnect the EMC filter (EMC) or ground-to-phase varistor (VAR). For instructions on how to do this, see page 19.

R6-
R9

EN

Frame sizes	EMC filter (EMC)	Ground-to-phase varistor (VAR)	Symmetrically grounded TN systems (TN-S systems) ¹	Corner grounded TN systems ²	IT systems (ungrounded or high-resistance grounded [>30 ohms]) ³
R6...R9	EMC (2 screws)	-	Do not disconnect	Disconnect	Disconnect
	-	VAR (1 screw)	Do not disconnect	Do not disconnect	Disconnect

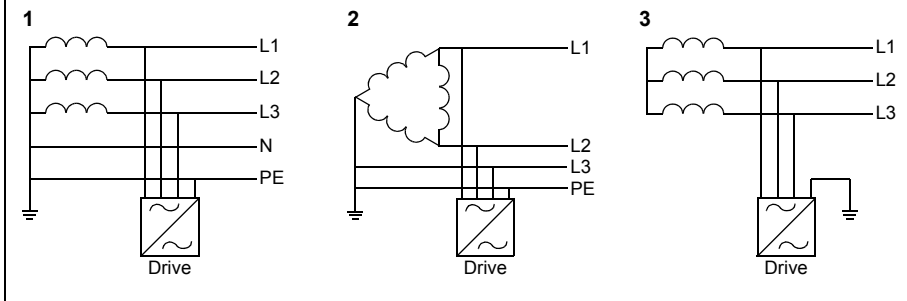

■ Disconnect EMC filter or ground-to-phase varistor, if needed

To disconnect the internal EMC filter or ground-to-phase varistor, if needed, do as follows:

1. Switch off the power from the drive.
2. Open the front cover, if not already opened, see steps 5, IP21 and 5, IP55 in figure [R6...R9 Figures A](#) on page 157.
3. To disconnect the internal EMC filter, remove the two EMC screws.
4. To disconnect the ground-to-phase varistor, remove the varistor screw.

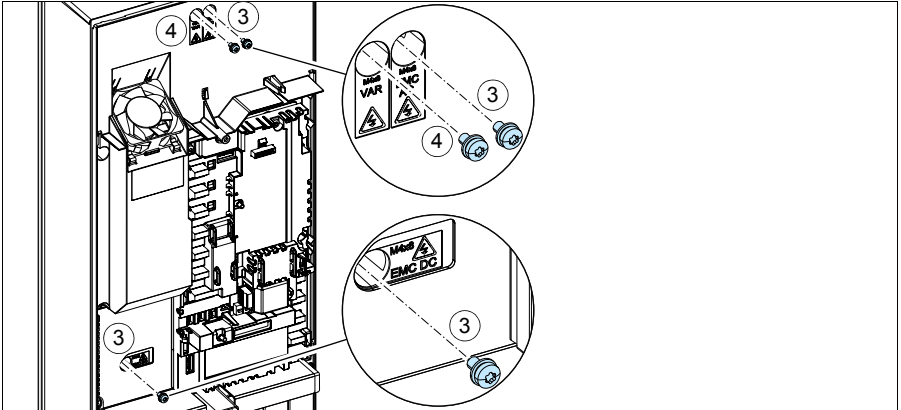
R6-
R9

EN

Connect the power cables

See figure C on page 157. Use symmetrical shielded cable for motor cabling. If the cable shield is the sole PE conductor for drive or motor, make sure that it has sufficient conductivity for the PE.

1. Attach the residual voltage warning sticker in the local language next to the control board.
 - R6-R9** 2. Remove the side plates of the cable entry box: Loosen the retaining screws and slide the walls out.
 3. Remove the shroud on the power cable terminals by releasing the clips with a screwdriver and pulling the shroud out.
 4. Knock out holes for the cables to be installed.
 - EN** 5. Cut an adequate hole into the rubber grommet. Slide the grommet onto the cable.
 6. Prepare the ends of the input power cable and motor cable as illustrated in the figure. **Note:** The bare shield will be grounded 360 degrees. Mark the pigtail made from the shield as a PE conductor with yellow-and-green color.
 7. Slide the cables through the holes of the bottom plate and attach the grommets to the holes (the motor cable to the right and the input power cable to the left).
 8. Connect the motor cable:
 - Ground the shield 360 degrees under the grounding clamp (8a).
 - Connect the twisted shield of the cable to the grounding terminal (8b).
 - Connect the phase conductors of the cable to terminals T1/U, T2/V and T3/W. Tighten the screws to the torque given in the figure (8c). **Note:** Phase conductors (R8, R9) are detachable.
 9. Connect the input power cable as in step 8. Use terminals L1, L2 and L3.
 10. R8...R9: If you install parallel, install the second grounding shelf for the parallel power cables. Repeat steps 5...9.
 11. Install the grounding shelf for the control cables.
 12. Reinstall the shroud on the power terminals.
 13. Secure the cables outside the unit mechanically.
 14. Ground the motor cable shield at the motor end. For minimum radio frequency interference, ground the motor cable shield 360 degrees at the lead-through of the motor terminal box.
-

Connect the control cables

See figure *D* on page 158. It shows an example with one analog signal cable and one digital signal cable. Make the connections according to the default configuration in use. The default connections of the HVAC default configuration are shown in section *Default I/O connections* on page 22.

Example of connecting an analog signal cable:

1. Cut an adequate hole into the rubber grommet and slide the grommet onto the cable. Slide the cable through a hole of the bottom plate and attach the grommet to the hole.
2. Ground the stripped outer shield of the cable 360 degrees under the grounding clamp. Keep the cable otherwise unstripped as close to the terminals of the control board as possible. For analog signal cables, ground also the pair-cable shields and grounding wire at the SCR1 terminal. Secure the cables mechanically at the clamps below the control board.
3. Route the cable as shown in the figure.
4. Connect the conductors to the appropriate terminals of the control board and tighten to 0.5...0.6 N·m (0.4 lbf·ft).
5. Tie all control cables to the provided cable tie mounts.
6. Put the unused rubber grommets to the holes in the lead-through plate.

**R6-
R9****EN**

Default I/O connections

Default I/O connections of the HVAC default configuration are shown below.

R6-
R9

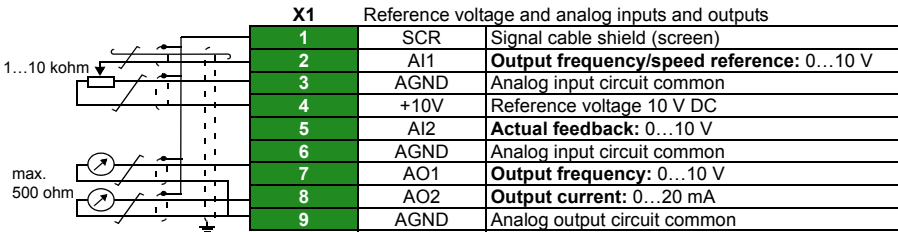

EN

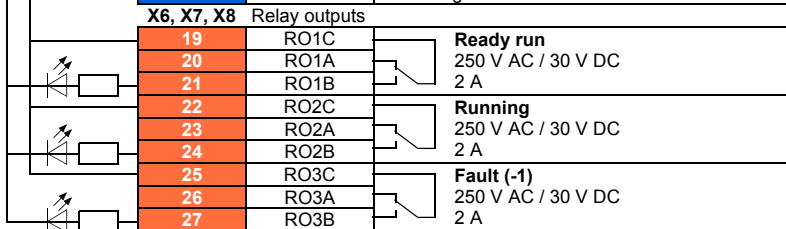
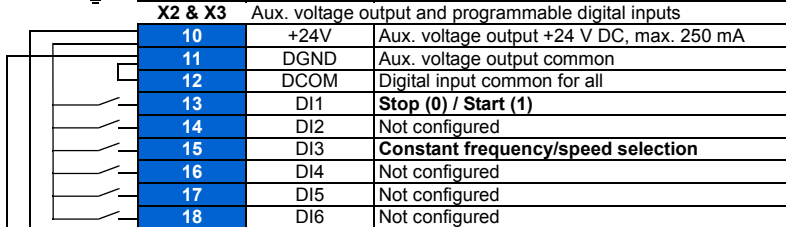

X5 Embedded fieldbus		
29	B+	Embedded fieldbus, EFB (EIA-485)
30	A-	
31	DGND	
S4	TERM	Termination switch
S5	BIAS	Bias resistors switch

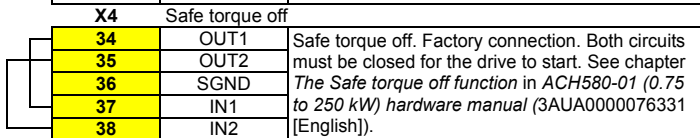

X10 24 V AC/DC		
40	24 V AC/DC+ in	Ext. 24 V AC/DC input to power up the control unit when the main supply is disconnected.
41	24 V AC/DC- in	

Total load capacity of the Auxiliary voltage output +24V (X2:10) is 6.0 W (250 mA / 24 V DC).

Wire sizes: 0.14...2.5 mm² (26...16 AWG): All terminals

Tightening torques: 0.5...0.6 N·m (0.4 lbf·ft)

Install optional modules, if any

See chapter *Electrical installation* in *ACH580-01 (0.75 to 250 kW) hardware manual* (3AUA0000076331 [English]).

Install side plates and covers

See figure *R6...R9 Figures E* on page 159.

**R6-
R9**

IP21

1. Reinstall the side plates of the cable entry box. Tighten the retaining screws with a screwdriver.
2. Slide the cover of the cable entry box on the module from below until the cover snaps into place.
3. Reinstall the module cover. Tighten the two retaining screws with a screwdriver.

EN

IP55

1. Reinstall the module cover. Tighten the two retaining screws with a screwdriver.

For start-up instructions, see chapter *EN – Quick start-up guide* on page 163.

R6-
R9

EN

DA – R6...R9 Hurtig installationsvejledning

Denne guide er en kortfattet beskrivelse af, hvordan du installerer frekvensomformerer. Du finder fuldstændige oplysninger om installationen i *ACH580-01 (0.75 to 250 kW) hardware manual* (3AUA0000076331 [på engelsk]). Se opstartsinstruktionerne i kapitlet [DA – Vejledning til hurtig opstart](#) på side 169.

R6-
R9

Du kan læse en manual ved at gå til www.abb.com/drives/documents og søge efter dokumentnummeret.

Overhold sikkerhedsinstruktionerne



ADVARSEL! Følg disse instruktioner. Hvis de ignoreres, kan det resultere i personskader, dødsfald eller skade på udstyret:

- Elektrisk installationsarbejde må kun udføres af uddannede elektrikere.
- Undlad at arbejde med frekvensomformerer, motorkablet eller motoren, når tilslutning til nettet er foretaget. Hvis frekvensomformerer allerede er tilsluttet netforsyning, skal du vente 5 minutter efter frakobling af netspændingen.
- Der må ikke arbejdes med signalkablerne, når netspændingen er tilsluttet frekvensomformerer eller de eksterne styrekredse.
- Brug frekvensomformerens løfteøjer, når du skal løfte den. Frekvensomformerer må ikke vippe. Frekvensomformerer er tung og har et højt tyngdepunkt. En frekvensomformer, der vælter, kan forårsage fysisk skade.
- Undgå, at der trænger smuds fra borer og sliberester ind i frekvensomformerer under installation.
- Sørg for, at gulvet under frekvensomformerer og den væg, hvor frekvensomformerer installeres, ikke er brændbare.

DA

Kontrollér, om det er nødvendigt at reformere kondensatorerne

Hvis frekvensomformerer ikke har været tilsluttet spænding (opbevaret eller ikke anvendt) i over et år, skal du reformere kondensatorerne.

Du kan bestemme produktionstidspunktet ud fra serienummeret, som du finder på typebetegnelsesmærket på frekvensomformerer. Serienummeret har formatet MYYYWWRXXXX. YY og WW angiver produktionsåret og ugen på følgende måde:

YY: 13, 14, 15, ... for 2013, 2014, 2015,
WW: 01, 02, 03, ... for uge 1, uge 2, uge 3, ...

Oplysninger om reformering af kondensatorer findes i *Converter module capacitor reforming instructions* (3BFE64059629 [på engelsk]), som findes på internettet på www.abb.com/drives/documents.

Vælg effektkabler

Vælg en størrelse til kablerne i henhold til lokale forskrifter til at bære den nominelle strøm, der er anført på mærket med typebetegnelsen på din frekvensomformer.

R6-
R9

Sørg for kølingen

Se tabel I på side 13 (UL: tabel II på side 13) vedrørende varmeafledningen. Frekvensomformerens tilladte driftstemperaturområde er -15 til +50 °C (+5 til +122 °F). Kondensation eller frost er ikke tilladt. Yderligere oplysninger om omgivelsestemperatur og reduktion finder du i kapitlet *Technical data* i *ACH580-01 (0.75 to 250 kW) hardware manual* (3AJA0000076331 [på engelsk]).

DA

Beskyt frekvensomformerer og netkablet

Se tabel III, IV og V på side 14 og 14 vedrørende sikringerne.

Hvis du bruger gG-sikringer, skal du sørge for, at sikringens funktionstid er under 0,5 sekund. Følg de lokale bestemmelser.

Installer frekvensomformerer på væggen

 **Advarsel!** Frekvensomformermodul er tungt (42 til 103 kg / 93 til 227 lb). Brug en egnet løfteanordning. Løft ikke modulet manuelt. Sørg for, at væggen og fastgørelsesanordningerne kan understøtte vægten.

Se figur R6...R9 Figures A på side 157.

Kontrollér isoleringen på effektkablerne og motoren

Kontrollér isoleringen af indgangskablet i overensstemmelse med de nationale forskrifter, inden det tilsluttes frekvensomformereren.

Se figur **B** på side **157**.

1. Kontrollér isoleringen af motorkablet og motoren, inden det tilsluttes frekvensomformereren. Mål isolationsmodstanden mellem hver faseleder og derefter mellem hver faseleder og beskyttelsesjordens leder med en målespænding på 1000 V DC. Isolationsmodstanden på en typisk motor skal være større end 100 Mohm (referenceværdi ved 25 °C eller 77 °F). Oplysninger om isolationsmodstanden på motorer kan findes i producentens vejledninger.

R6-
R9

Bemærk! Fugt inden i motorhuset reducerer isolationsmodstanden. Hvis der er mistanke om fugt, skal motoren tørres, og målingen gentages.

Kontrollér kompatibiliteten med IT-net (ujordede) og hjørnejordede TN-net

DA

■ EMC-filter

Det interne EMC-filter egner sig ikke til anvendelse på et IT-net (jordet) eller på et hjørnejordet TN-net. Frakobl EMC-filteret, før du slutter frekvensomformereren til forsyningsnettet. Kontrollér tabellen på side **28**.



ADVARSEL! Installér ikke frekvensomformereren med det interne EMC-filter tilsluttet på et IT-net (et ikke-jordet net eller et højimpedansjordet net [mere end 30 ohm]). Ellers vil systemet blive tilsluttet jordpotentialet via frekvensomformerens EMC-filterkondensatorer. Dette kan medføre fare eller ødelægge frekvensomformereren.

Installér ikke en frekvensomformer med det interne EMC-filter tilsluttet på et hjørnejordet TN-net, ellers bliver frekvensomformereren beskadiget.

Bemærk! Når det interne EMC-filter frakobles, reduceres frekvensomformerens EMC-kompatibilitet betydeligt.

■ Jord til fase-varistor

Jord til fase-varistoren er ikke egnet til brug på et (ujordet) IT-system. Frakobl jord til fase-varistoren, før du slutter frekvensomformereren til forsyningsnettet. Kontrollér tabellen på side **28**.



ADVARSEL! Installér ikke frekvensomformeren med jord til fase-varistoren tilsluttet på et IT system (et ikke-jordet net eller et højimpedansjordet net (mere end 30 ohm)). Ellers kan varistorkredsløbet tage skade.

Kontrollér i henhold til tabellen nedenfor, om du skal frakoble EMC-filteret (EMC) eller jord til fase-varistoren (VAR). Se side 29 for at få instruktioner i, hvordan dette gøres.

R6-
R9

Modulstørrelser	EMC-filter (EMC)	Jord til fase-varistor (VAR)	Symmetrisk jordede TN-systemer (TN-S-systemer) ¹	Hjørnejordede TN-systemer ²	IT-net (ujordede eller højmodstands-jordede [>30 ohms]) ³
R6...R9	EMC (2 skruer)	-	Frakobl ikke	Frakoblet	Frakoblet
	-	VAR (1 skrue)	Frakobl ikke	Frakobl ikke	Frakoblet

DA

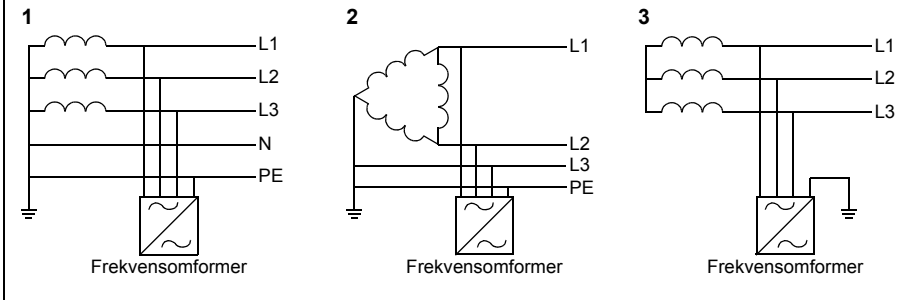

■ Frakobl om nødvendigt EMC-filteret eller jord til fase-varistoren

Du kan frakoble det interne EMC-filter eller jord til fase-varistoren, hvis det er nødvendigt, på følgende måde:

1. Sluk for strømmen til frekvensomformeren.
2. Åbn forsideomslaget, hvis det ikke allerede åbent. Se trin 5, IP21 og 5, IP55 på figur *R6...R9 Figures A* på side 157.
3. Du kan frakoble det interne EMC-filter ved at fjerne de to EMC-skruer.
4. Du kan frakoble jord til fase-varistoren ved at fjerne varistorens skrue.

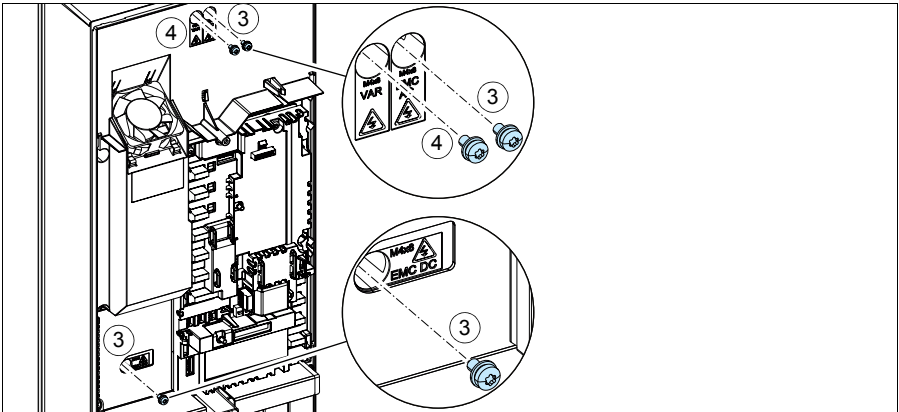
R6-
R9

DA

Tilslut effektkablerne

Se figur C på side 157. Anvend et skærmet symmetrisk kabel til motorkabling. Hvis kabelskærmen er den eneste PE-leder til frekvensomformereren eller motoren, skal du sørge for, at den har tilstrækkelig ledeevne til PE'en.

1. Fastgør advarselmærkatet om restspænding på det lokale sprog ved siden af styrekortet.
2. Fjern sidepladerne fra kabelindgangskassen: Løsn holdeskruerne, og træk panelerne ud.
3. Fjern afskærmningen på netkabelterminalerne ved at løsne splitterne med en skruetrækker og trække afskærmningen ud.
4. Slå hullerne ud, hvor kablerne skal installeres.
5. Skær et tilstrækkeligt stort hul i gummimuffen. Træk muffen over på kablet.
6. Forbered enderne på net- og motorkablet som vist på figuren. **Bemærk!** Afskærmningen jordes 360 grader. Markér det øje, der dannes af skærmen, som en PE-leder med gult og grønt.
7. Før kablerne gennem hullerne i bundpladen, og sæt mufferne fast i hullerne (motorkablet til højre og netkablet til venstre).
8. Kontrollér motorkablet:
 - Jord skærmen 360 grader under jordingsklemmen (8a).
 - Forbind den snoede del af kabelskærmen med jordingsterminalen (8b).
 - Slut kablets faseledere til terminalerne T1/U, T2/V og T3/W Spænd skruerne til momentet, der er angivet på figur (8c). **Bemærk!** Faseledere (R8, R9) kan afmonteres.
9. Tilslut netkablet som i trin 8. Anvend terminal L1, L2 og L3
10. R8...R9: Hvis du installerer parallelt, skal du installere den anden jordingsplint for de parallelle netkabler. Gentag trin 5...9.
11. Installér styrekablernes jordingsterminal.
12. Geninstallér afskærmningen på strømterminalerne.
13. Fastgør kablerne uden for enheden mekanisk.
14. Tilslut motorkabelskærmen i motorenden. For at opnå mindst mulig radiofrekvensinterferens jordes motorkabelskærmen 360 grader ved motorklemkassens gennemføring.

R6-
R9

DA

Tilslutning af styrekablerne

Se figur [D](#) på side [158](#). Den viser et eksempel med ét analogsignalkabel og ét digitalsignalkabel. Foretag tilslutningerne i henhold til standardkonfigurationen. Standardtilslutningerne for HVAC-standardkonfigurationen er vist i afsnittet [I/O-standardtilslutninger](#) på side [32](#).

Eksempel på tilslutning af et analogsignalkabel:

1. Klip et passende hul i gummimuffen, og skub muffen på kablet. Før kablet gennem et hul i bundpladen, og sæt muffen fast i hullet.
2. Jord den afisolerede udvendige skærm på kablet 360 grader under jordingsklemmen. Resten af kablet skal være isoleret så tæt på terminalerne på styrekortet som muligt. For analogsignalkabler skal også skærmene på de parsnoede kabler og jordkablet ved SCR1-terminalen jordes. Fastgør kablerne mekanisk på klemmerne under styrekortet.
3. Før kablet som vist på figuren.
4. Slut lederne til styrekortets relevante terminaler, og spænd til 0,5...0,6 Nm (0,4 lbf-ft).
5. Bind alle styrekabler fast til de medfølgende kabelbinderbeslag.
6. Montér de ikke-anvendte gummimuffer i hullerne i gennemføringspladen.

R6-
R9

DA

I/O-standardtilslutninger

I/O-standardtilslutninger til HVAC-standardkonfigurationen er vist nedenfor.

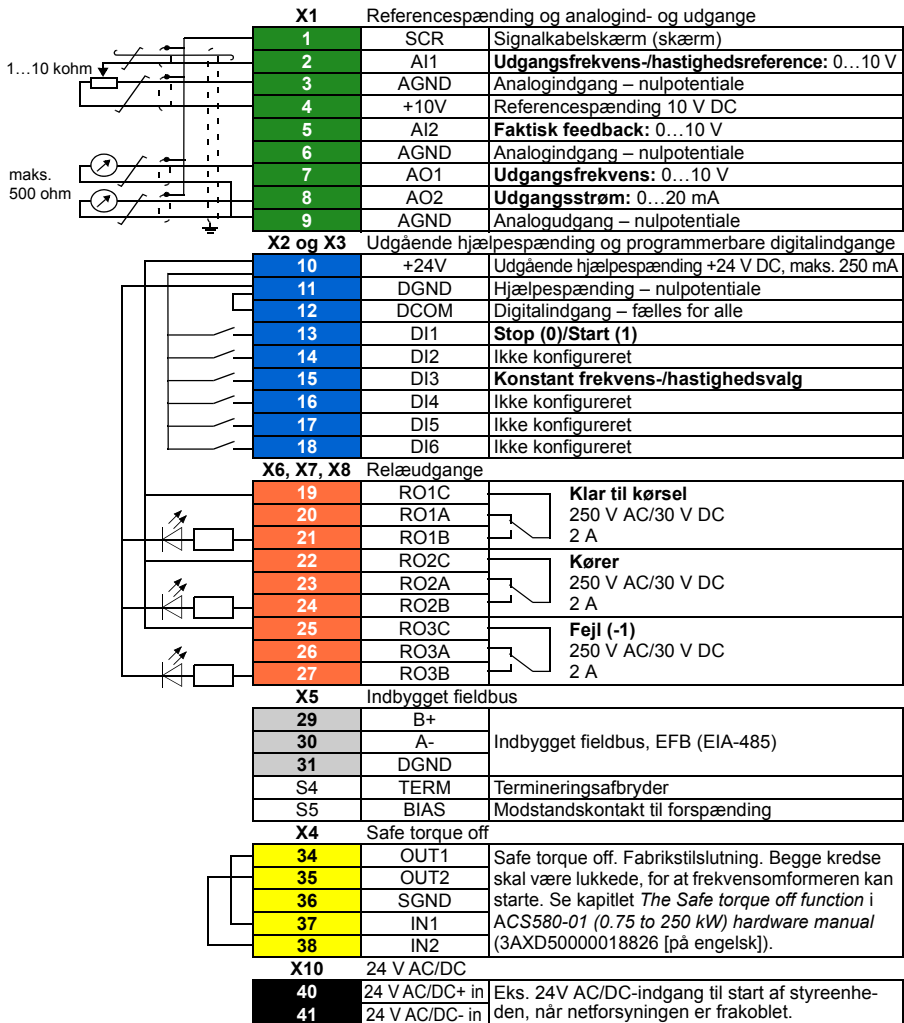

Den samlede belastningskapacitet for hjælpespændingsudgangen +24V (X2:10) er 6,0 W (250 mA/24 V DC).

Ledningsstørrelse: 0,14...2,5 mm² (26...16 AWG): Alle terminaler

Tilspændingsmomenter: 0.5...0.6 N·m (0.4 lbf·ft)

Installér valgfrie moduler, hvis de findes

Se kapitlet *Electrical installation* i *ACH580-01 (0.75 to 250 kW) hardware manual* (3AUA0000076331 [på engelsk]).

Installér sideplader og dæksler

Se figur *R6...R9 Figures E* på side 159.

R6-
R9

IP21

1. Montér sidepladerne på kabelindgangskassen. Stram holdeskruerne med en skruetrækker.
2. Skub kabelindgangskassens dæksel på modulet nedefra, indtil dækslet klikker på plads.
3. Geninstallér modulets dæksel. Stram de to holdeskruer med en skruetrækker.

IP55

1. Geninstallér modulets dæksel. Stram de to holdeskruer med en skruetrækker.

DA

Se opstartsinstruktionerne i kapitlet *DA – Vejledning til hurtig opstart* på side 169.

R6-
R9

DA

DE – R6...R9 Kurzanleitung für die Installation

Diese Kurzanleitung beschreibt die Installation des Frequenzumrichters. Die vollständigen Informationen für die Installation enthält das *Hardware-Handbuch ACH580-01 Frequenzumrichter (0.75 bis 250 kW)* (3AXD50000027539 [deutsch]). Die Inbetriebnahmeanleitung enthält Kapitel *DE – Kurzanleitung für die Inbetriebnahme* auf Seite 175.

Die Handbücher finden Sie im Internet unter www.abb.com/drives/documents, und suchen Sie dort anhand der Dokumentennummer.

R6-
R9

Befolgen Sie die Sicherheitsvorschriften



WARNUNG! Befolgen Sie diese Vorschriften. Wenn diese nicht befolgt werden, können Verletzungen, tödliche Unfälle oder Schäden an den Geräten auftreten:

- Elektrische Installationsarbeiten dürfen nur von Fachpersonal durchgeführt werden.
- Am Frequenzumrichter, dem Motorkabel oder dem Motor dürfen keinerlei Arbeiten ausgeführt werden, solange die Netzspannung anliegt. Wenn der Frequenzumrichter bereits an die Spannungsversorgung angeschlossen ist/war, warten Sie 5 Minuten nach der Trennung von der Eingangsspannung.
- Führen Sie keine Arbeiten an den Steuerkabeln durch, wenn Spannung am Frequenzumrichter oder externen Steuerkreisen anliegt.
- Verwenden Sie zum Anheben die Hebeösen des Frequenzumrichters. Der Frequenzumrichter darf nicht gekippt werden. Der Frequenzumrichter ist schwer und hat einen hoch liegenden Schwerpunkt. Wenn er umfällt, kann er schwere Verletzungen verursachen.
- Stellen Sie sicher, dass bei der Installation keine Bohrspäne und Staub in den Frequenzumrichter eindringen.
- Stellen Sie sicher, dass der Boden unterhalb des Frequenzumrichters und die Wand, an der Frequenzumrichter montiert wird, aus nicht brennbarem Material bestehen.

DE

Prüfen Sie, ob Kondensatoren nachformiert werden müssen

Wenn der Frequenzumrichter noch nicht oder seit mehr als einem Jahr nicht an die Spannungsversorgung angeschlossen war (entweder gelagert oder nicht benutzt), müssen die Kondensatoren formiert werden.

Das Herstellungsdatum kann anhand der Seriennummer bestimmt werden, welche auf dem Typenschild (seitlich am Frequenzumrichter angebracht) angegeben ist. Die Seriennummer hat das Format MJJWWRXXXX. JJ und WW geben das Herstellungsjahr und die -woche an:

JJ: 13, 14, 15, ... für 2013, 2014, 2015, ...

WW: 01, 02, 03, ... für Woche 1, Woche 2, Woche 3, ...

Informationen zum Formieren der Kondensatoren enthält die Anleitung *Converter module capacitor reforming instructions* (3BFE64059629 [englisch]), verfügbar im Internet auf www.abb.com/drives/documents.

R6-
R9

Auswahl der Leistungskabel

Die Leistungskabel müssen nach den örtlichen Vorschriften für den auf dem Typenschild des Frequenzumrichters angegebenen Nennstrom ausreichend bemessen sein.

Ausreichende Kühlung sicherstellen

Siehe Tabelle I auf Seite 13 (UL: Tabelle II auf Seite 13) bezüglich der Wärmeableitung. Der zulässige Umgebungstemperaturbereich für den Betrieb des Frequenzumrichters beträgt -15 bis +50 °C (+5 bis +122 °F). Kondensation und/oder Vereisung sind nicht zulässig. Weitere Informationen zur Umgebungstemperatur und Leistungsminderung enthält Kapitel *Technische Daten* im Handbuch *ACH580-01 Frequenzumrichter (0,75 bis 250 kW)* (3AXD50000027539 [deutsch]).

DE

Schutz des Frequenzumrichters und der Eingangskabel

Angaben zu den Sicherungen enthalten die Tabellen III, IV und V auf den Seiten 14 und 14.

Wenn Sie Sicherungen des Typs gG benutzen, prüfen Sie anhand der Zeit-Stromkurve der Sicherung, ob die Ansprechzeit unter 0,5 Sekunden liegt. Befolgen Sie die örtlichen Vorschriften.

Wandmontage des Frequenzumrichters



Warnung! Das Frequenzumrichtermodul ist schwer (42 bis 103 kg / 93 bis 227 lb). Verwenden Sie eine geeignete Hebevorrichtung. Das Modul darf nicht manuell angehoben werden. Stellen Sie sicher, dass Wand und Befestigungsvorrichtungen das Gewicht tragen können.

Siehe Abbildung *R6...R9 Figures A* auf Seite 157.

Prüfung der Isolation der Einspeise- und Motorkabel und des Motors

Prüfen Sie, ob die Isolation des Einspeise-/Netzanschlusskabels den örtlichen Vorschriften entspricht, bevor dieses an den Frequenzumrichter angeschlossen wird.

Siehe Abbildung **B** auf Seite **157**.

1. Prüfen Sie die Isolation des Motorkabels und des Motors, wenn das Motorkabel vom Frequenzumrichter getrennt ist. Messen Sie die Isolationswiderstände zwischen jeweils zwei Phasenleitern sowie jedem Phasenleiter und der Schutzerde mit einer Messspannung von 1000 V DC. Der Isolationswiderstand eines typischen Motors muss mehr als 100 MOhm betragen (Referenzwert bei 25 °C bzw. 77 °F). Die Isolationswiderstände anderer Motoren entnehmen Sie bitte der jeweiligen Anleitung des Herstellers.

Hinweis: Feuchtigkeit innerhalb des Motorgehäuses reduziert den Isolationswiderstand. Bei Verdacht auf Feuchtigkeit muss der Motor getrocknet und die Messung wiederholt werden.

Prüfung der Kompatibilität mit IT- (ungeerdeten) und asymmetrisch geerdeten TN-Netzen

■ EMV-Filter

Der interne EMV-Filter ist für die Verwendung in IT- (ungeerdeten) und asymmetrisch geerdeten TN-Netzen nicht geeignet. Trennen Sie den EMV-Filter, bevor Sie den Frequenzumrichter an das Einspeisenetz anschließen. Siehe Tabelle auf Seite **38**.



WARNUNG! Schließen Sie den Frequenzumrichter nicht an ein IT-System (ein nicht geerdetes oder hochohmig geerdetes Netz [über 30 Ohm]) an, wenn der interne EMV-Filter nicht getrennt worden ist, da sonst das Netz über die EMV-Filterkondensatoren des Frequenzumrichters mit dem Erdpotenzial verbunden wird. Dadurch können Gefahren entstehen oder der Frequenzumrichter kann beschädigt werden.

Schließen Sie den Frequenzumrichter nicht an ein asymmetrisch geerdetes TN-Netz an, wenn der EMV-Filter nicht getrennt worden ist, da sonst der Frequenzumrichter beschädigt werden kann.

Hinweis: Bei getrenntem internen EMV-Filter ist die EMV-Kompatibilität des Frequenzumrichters deutlich geringer.

Erde-Phase-Varistor

Der Erde-Phase-Varistor ist für die Verwendung in IT- (ungeerdeten) Netzen nicht geeignet. Trennen Sie den Erde-Phase-Varistor, bevor Sie den Frequenzumrichter an das Einspeisernetz anschließen. Siehe Tabelle auf Seite 38.



WARNUNG! Der Frequenzumrichter darf mit dem Erde-Phase-Varistor nicht an ein IT-Netz (ein ungeerdetes oder ein hochohmig geerdetes [über 30 Ohm] Netz) angeschlossen werden, da sonst der Varistor-Schaltkreis beschädigt werden kann.

R6-
R9

Prüfen Sie anhand der folgenden Tabelle, ob der EMV-Filter (EMC) oder der Erde-Phase-Varistor (VAR) getrennt werden müssen. Anweisungen dazu finden Sie auf Seite 39.

Bau- größe	EMV- Filter (EMC)	Erde- Phase- Varistor (VAR)	Symmetrisch geerdete TN-Netze (TN-S-Netze) ¹	Asymmetrisch geerdete TN-Netze ²	IT-Systeme (ungeerdet oder hochohmig geerdet [>30 Ohm]) ³
R6...R9	EMV (2 Schrau- ben)	-	Nicht trennen	Trennen	Trennen
	-	VAR (1 Schrau- be)	Nicht trennen	Nicht trennen	Trennen

DE

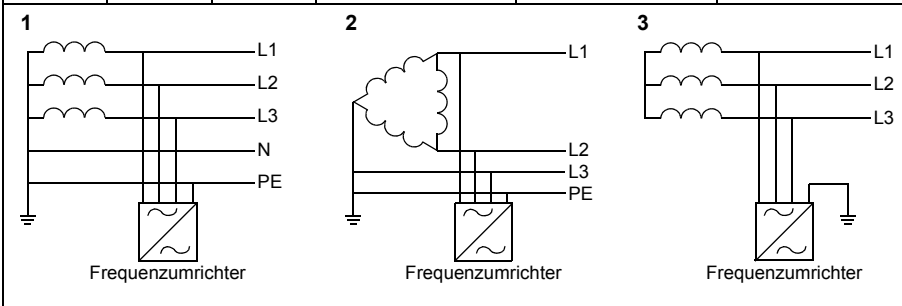

■ Trennen des EMV-Filters oder Erde-Phase-Varistors, falls erforderlich

Zum Trennen des internen EMV-Filters oder des Erde-Phase-Varistors, falls erforderlich, gehen Sie wie folgt vor:

1. Die Spannungsversorgung des Frequenzumrichters abschalten und 5 Minuten warten, bevor Sie weiterarbeiten.
2. Entfernen Sie die vordere Abdeckung, falls diese noch nicht entfernt worden ist, siehe Schritt 5, IP21 und 5, IP55 in Abbildung [R6...R9 Figures A](#) auf Seite [157](#).
3. Zum Trennen des internen EMV-Filters die zwei EMV-Schrauben (EMC) entfernen.
4. Zum Trennen des Erde-Phase-Varistors die Varistorschraube entfernen.

R6-
R9

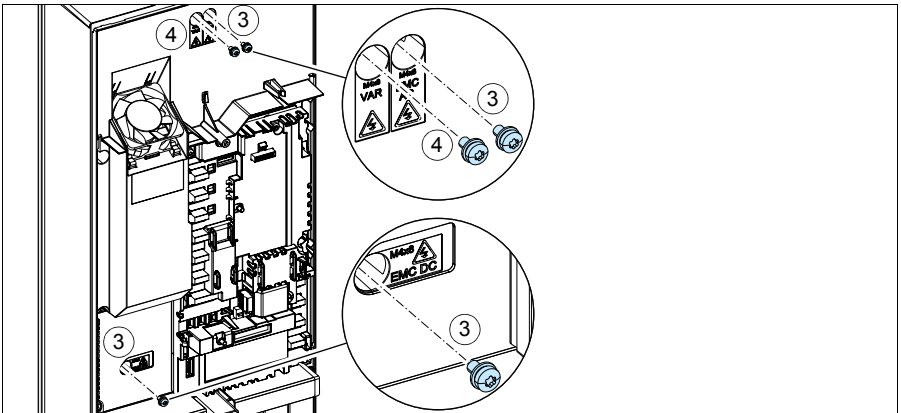

DE

Anschluss der Leistungskabel

Siehe Abbildung C auf Seite 157. Ein symmetrisch geschirmtes Motorkabel verwenden. Wenn der Kabelschirm der einzige PE-Leiter für den Frequenzumrichter oder Motor ist, stellen Sie sicher, dass er eine ausreichend bemessene Leitfähigkeit für PE hat.

R6-
R9

1. Den Restspannungs-Warnaufkleber in der erforderlichen lokalen Sprache neben der Regelungseinheit anbringen.
2. Die Seitenverkleidungen des Kabelanschlusskastens entfernen. Die Befestigungsschrauben lösen und die Trennbleche herausnehmen.
3. Die Abdeckung von den Leistungskabelklemmen entfernen; hierzu die Clips mit einem Schraubendreher lösen und die Abdeckung herausziehen.
4. Die Öffnungen für die zu installierenden Kabel ausbrechen.
5. Passende Öffnungen in die Gummidichtungen schneiden. Die Dichtungen auf die Kabel schieben.

DE

6. Die Enden des Netzanschlusskabels und des Motorkabels wie in der Abbildung gezeigt vorbereiten. **Hinweis:** Der blanke Schirm des Kabels muss 360 Grad geerdet werden. Kennzeichnen Sie das verdrehte Schirmbündel als PE-Leiter mit einer gelb-grünen Markierung.
 7. Stecken Sie die Kabel durch die Bohrungen in der Bodenplatte und setzen Sie die Gummi-Durchführungsdichtungen in die Bohrungen (das Motorkabel rechts und das Leistungskabel links).
 8. Anschließen des Motorkabels:
 - Den Schirm 360 Grad erden, indem die Kabelschelle für die Leistungskabelerdung über den abisolierten Teil des Kabels gelegt und verschraubt wird (8a).
 - Den verdrehten Schirm des Kabels an die PE-Klemme anschließen (8b).
 - Die Phasenleiter des Kabels an die Klemmen T1/U, T2/V und T3/W anschließen. Die Schrauben mit dem in der Abbildung (8c) angegebenen Anzugsmoment festziehen. **Hinweis:** Die Phasenleiter (R8, R9) sind abnehmbar.
 9. Das Netzanschlusskabel, wie in Schritt 8 beschrieben, anschließen. Dafür die Klemmen L1, L2 und L3 verwenden.
 10. R8...R9: Bei parallelem Anschluss mehrerer Module (Baugrößen R8...R9) installieren Sie die zweite Erdungsanschlussschiene für die Netzanschlusskabel der parall geschalteten Module. Die Schritte 5...9 wiederholen.
 11. Die Erdungsschiene für die Steuerkabel installieren.
 12. Die Abdeckung wieder auf den Leistungskabelklemmen anbringen.
 13. Die Kabel außerhalb der Einheit mechanisch sichern.
-

14. Die Motorkabelschirme motorseitig an Erde/PE anschließen. Für minimale HF-Störungen muss der Kabelschirm an der Eingangsverschraubung des Motorklemmenkastens mit einer 360-Grad-Erdung versehen werden.

Anschluss der Steuerkabel

Siehe Abbildung *D* auf Seite 158. Es wird ein Beispiel mit einem Analogsignalkabel und einem Digitalsignalkabel gezeigt. Installieren Sie die Anschlüsse entsprechend der benutzten Standard-Konfiguration. Die Standardanschlüsse der HLK-Standard-Konfiguration werden in Abschnitt *Standard E/A-Anschlüsse* auf Seite 42 gezeigt.

R6-
R9

Beispiel für den Anschluss eines Analogsignalkabels:

1. Eine passende Öffnung in die Gummidurchführungsdichtung schneiden und die Dichtung auf das Kabel schieben. Das Kabel durch die Öffnung des unteren Abschlussblechs stecken und die Dichtung in die Öffnung drücken.
2. Den abisolierten äußeren Schirm des Kabels 360 Grad unter die Erdungsklemme stecken und die Klemme verschrauben. Das Kabel mit durchgängigem Schirm so nahe wie möglich an die Klemmen der Regelungseinheit führen. Für Analogsignalkabel auch die beiden Schirme der paarweisen Einzelleiter und den Erdungsleiter an Klemme SCR1 anschließen (erden). Die Kabel an den Schellen unter der Regelungseinheit mechanisch sichern.
3. Die Kabel so, wie in der Abbildung gezeigt, verlegen.
4. Die Leiter an die entsprechenden Klemmen der Regelungseinheit anschließen und mit 0,5...0,6 Nm (0,4 lbf·ft) festziehen.
5. Alle Steuerkabel an den vorgesehenen Kabelhalterungen befestigen.
6. Die unbenutzten Gummidichtungen in die Öffnungen der Durchführungsplatte stecken.

DE

Standard E/A-Anschlüsse

Im folgenden Anschlussplan sind die Standard-E/A-Anschlüsse der HLK-Standard-Konfiguration dargestellt.

R6-
R9

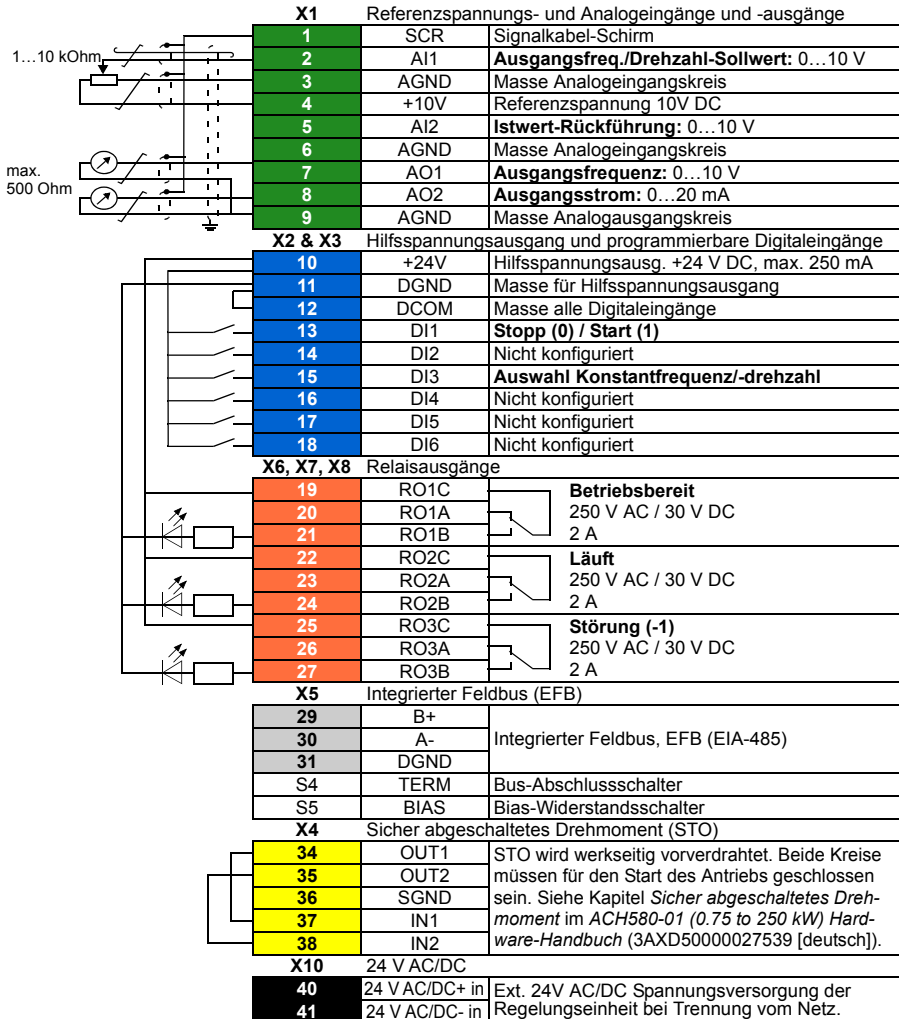

DE

Die Gesamtbelastbarkeit des Hilfsspannungsausgangs +24V (X2:10) beträgt 6,0 W (250 mA / 24 V DC).

Leitergrößen: 0,14...2,5 mm² (26...16 AWG): Alle Klemmen

Anzugsmomente: 0,5...0,6 Nm (0,4 lbf-ft)

Installation optionaler Module, falls vorhanden

Siehe Kapitel *Elektrische Installation* im *Hardware-Handbuch ACH580-01 Frequenzumrichter (0,75 bis 250 kW)* (3AXD50000027539 [deutsch]).

Installation der Seitenverkleidungen und Abdeckungen

Siehe Abbildung *R6...R9 Figures E* auf Seite 159.

R6-
R9

IP21

1. Die Seitenverkleidungen des Kabelanschlusskastens wieder montieren. Die Befestigungsschrauben mit einem Schraubendreher festziehen.
2. Die Abdeckung des Kabelanschlusskastens von unten auf das Modul schieben, bis sie einrastet.
3. Die Modulabdeckung wieder montieren. Die zwei Befestigungsschrauben mit einem Schraubendreher festziehen.

IP55

1. Die Modulabdeckung wieder montieren. Die zwei Befestigungsschrauben mit einem Schraubendreher festziehen.

DE

Die Inbetriebnahmeanleitung enthält Kapitel *DE – Kurzanleitung für die Inbetriebnahme* auf Seite 175.

R6-
R9

DE

ES – Guía rápida de instalación para bastidores R6...R9

Esta guía describe brevemente cómo instalar el convertidor de frecuencia. Consulte la documentación completa sobre instalación en el *ACH580-01 (0.75 to 250 kW) hardware manual* (3AUA0000076331 [Inglés]). Para las instrucciones de puesta en marcha, véase el capítulo *ES – Guía rápida de puesta en marcha* en la página 181.

Para consultar un manual, entre en www.abb.com/drives/documents y busque el número del documento.

R6-
R9

Siga estrictamente las instrucciones de seguridad



ADVERTENCIA: Siga estas instrucciones. Si no se tienen en cuenta las instrucciones, pueden producirse lesiones físicas, muertes o daños en el equipo.

- Si no es un electricista cualificado, no realice ningún trabajo relacionado con la instalación eléctrica.
- No manipule el convertidor, el cable de motor ni el motor cuando el convertidor esté alimentado. Si el convertidor está conectado a la potencia de entrada, espere 5 minutos tras desconectarlo.
- No manipule los cables de control mientras el convertidor o los circuitos de control externo reciban alimentación.
- Use los cáncamos de elevación del convertidor para levantarlo. No incline el convertidor. El convertidor es pesado y su centro de gravedad alto. El vuelco de un convertidor puede producir lesiones.
- Asegúrese de que los restos de polvo y virutas resultantes de practicar orificios y rectificaciones no entren en el convertidor de frecuencia durante la instalación.
- Asegúrese de que el suelo sobre el que se apoya el convertidor y la pared sobre la que está instalado son ignífugos.

ES

Compruebe si es necesario reacondicionar los condensadores

Si el convertidor no ha recibido alimentación (estando almacenado o fuera de uso) durante un año o más, debe reacondicionar los condensadores.

Puede determinar la fecha de fabricación a partir del número de serie, que encontrará en la etiqueta de designación de tipo adherida al convertidor. El número de serie tiene el formato MAASSRXXXX. AA y SS indican el año y la semana de fabricación, de la forma siguiente:

AA: 13, 14, 15... para 2013, 2014, 2015...

SS: 01, 02, 03... para semana 1, semana 2, semana 3...

Para más información sobre el reacondicionamiento de los condensadores, consulte el documento *Converter module capacitor reforming instructions* (3BFE64059629 [Inglés]), disponible en Internet en www.abb.com/drives/documents.

R6-R9 Seleccione los cables de potencia

Dimensione los cables de potencia de conformidad con los reglamentos locales para el transporte de la intensidad nominal indicada en la etiqueta de designación de tipo de su convertidor de frecuencia.

Garantice la refrigeración

Consulte la disipación de calor en la tabla I en la página 13 (UL: tabla II en la página 13). El rango de temperatura de funcionamiento permitido para el convertidor de frecuencia es de -15 a +50 °C (+5 a +122 °F). No se permite ni condensación ni escarcha. Para obtener más información acerca de la temperatura ambiente y el derrateo, véase el capítulo *Technical data* en el *ACH580-01 (0.75 to 250 kW) hardware manual* (3AUA0000076331 [Inglés]).

ES

Proteja el convertidor y el cable de potencia de entrada

Consulte los fusibles en las tablas III, IV y V de las páginas 14 y 14.

Si emplea fusibles gG, compruebe que el tiempo de fusión del fusible sea inferior a 0,5 segundos. Siga los reglamentos locales.

Monte el convertidor de frecuencia en la pared

 **Advertencia:** El módulo de convertidor es pesado (de 42 a 103 kg / de 93 a 227 lb). Utilice un dispositivo de elevación adecuado. No levante el módulo de forma manual. Asegúrese de que la pared y los dispositivos de fijación puedan soportar el peso.

Véase la figura *R6...R9 Figures A* en la página 157.

Compruebe el aislamiento de los cables de potencia y del propio motor

Compruebe el aislamiento del cable de entrada de conformidad con la normativa local antes de conectarlo al convertidor de frecuencia.

Véase la figura *B* en la página 157.

1. Compruebe el aislamiento del cable de motor y del motor antes de conectarlo al convertidor de frecuencia. Mida la resistencia de aislamiento entre los conductores de fase y a continuación entre el conductor de cada fase y el conductor de conexión a tierra con una tensión de medición de 1000 V CC. La resistencia de aislamiento de un motor típico debe ser superior a los 100 Mohmios (valor de referencia a 25 °C o 77 °F). Para la resistencia de aislamiento de los motores, véanse las instrucciones del fabricante.

Nota: La humedad en el interior de la carcasa del motor reduce la resistencia de aislamiento. Si sospecha de la presencia de humedad, seque el motor y repita la medición.

Compruebe la compatibilidad con las redes IT (sin conexión a tierra) y redes TN con conexión a tierra en un vértice

■ Filtro EMC

El filtro EMC interno no es adecuado para su uso en una red IT (sin conexión a tierra) o red TN con conexión a tierra en un vértice. Desconecte el filtro EMC antes de conectar el convertidor de frecuencia a la red. Véase la tabla en la página 48.

 **ADVERTENCIA:** No instale el convertidor de frecuencia con el filtro EMC interno conectado a una red IT (sin conexión a tierra o con conexión a tierra de alta resistencia [por encima de 30 ohmios]), de lo contrario el sistema se conectará al potencial de tierra a través de los condensadores del filtro EMC del convertidor de frecuencia. Esto puede entrañar peligro o provocar daños en el convertidor.

No instale un convertidor con un filtro EMC interno conectado a una red TN con conexión a tierra en un vértice; de lo contrario el convertidor resultará dañado.

Nota: Cuando el filtro EMC interno está desconectado, la compatibilidad EMC del convertidor se reduce considerablemente.

■ Varistor tierra-fase

El varistor tierra-fase no es adecuado para una red IT (sin conexión a tierra). Desconecte el varistor tierra-fase antes de conectar el convertidor de frecuencia a la red. Véase la tabla en la página 48.



ADVERTENCIA: No instale el convertidor con el varistor tierra-fase conectado a una red IT (sin conexión a tierra o con conexión a tierra de alta resistencia [por encima de 30 ohmios]); de lo contrario, el circuito del varistor puede resultar dañado.

R6-
R9

Consulte la tabla siguiente si debe desconectar el filtro EMC (EMC) o el varistor tierra-fase (VAR). Para obtener instrucciones sobre cómo hacerlo, véase la página 49.

Tamaño de bastidor	Filtro EMC (EMC)	Varistor tierra-fase (VAR)	Redes TN conectadas a tierra simétricamente (Redes TN-S) ¹	Redes TN con conexión a tierra en un vértice ²	Redes IT (sin conexión a tierra o con conexión a tierra de alta resistencia [>30 ohmios]) ³
R6...R9	EMC (2 tornillos)	-	No desconectar	Desconectar	Desconectar
	-	VAR (1 tornillo)	No desconectar	No desconectar	Desconectar

ES

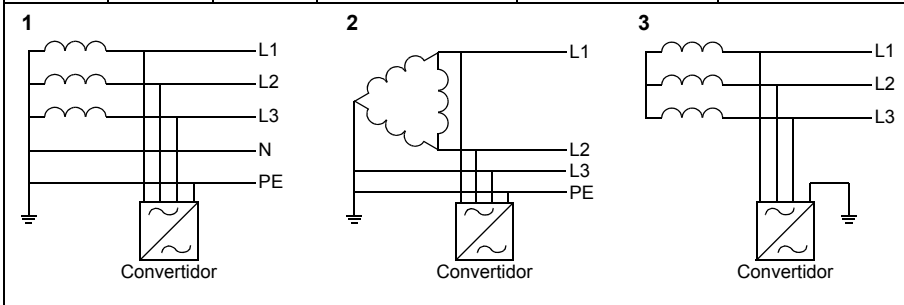

■ Desconecte el filtro EMC o el varistor tierra-fase, si es necesario

Si es necesario desconectar el filtro EMC interno o el varistor tierra-fase, siga los siguientes pasos:

1. Desconecte la alimentación del convertidor.
2. Abra la cubierta frontal, si no está abierta; siga los pasos 5 (IP21) y 5 (IP55) en la figura *R6...R9 Figures A* en la página 157.
3. Desconecte el filtro EMC interno extrayendo los dos tornillos del filtro EMC.
4. Desconecte el varistor retirando el tornillo del varistor.

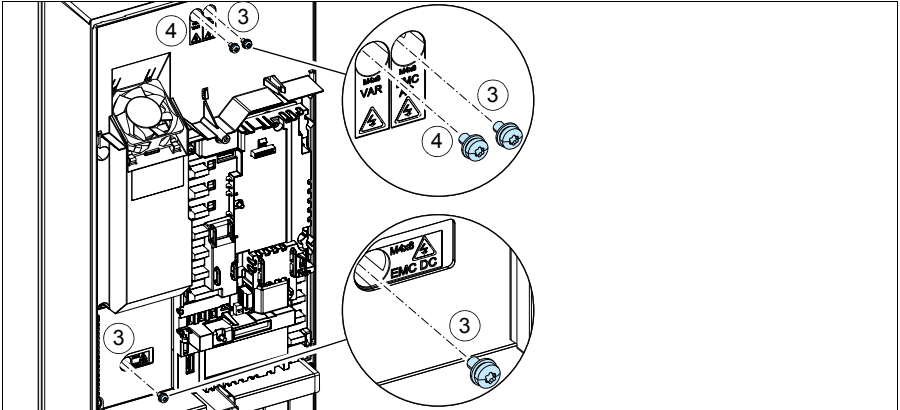
R6-
R9

ES

Conecte los cables de potencia

Véase la figura C de la página 157. Use cable apantallado simétrico para el cableado al motor. Si la pantalla del cable es el único conductor de conexión a tierra que tiene el convertidor o el motor, asegúrese de que tiene la conductividad suficiente como para ofrecer una protección adecuada de este tipo.

1. Pegue el adhesivo de advertencia de tensión residual en el idioma local junto a la tarjeta de control.
2. Retire las placas laterales de la caja de entrada de cables: Retire los tornillos de sujeción y deslice las paredes hacia fuera.
3. Retire la cubierta protectora de los terminales de los cables de potencia, liberando las presillas con un destornillador y tirando de la cubierta protectora para extraerla.
4. Practique los orificios que sean necesarios para poder pasar los cables.
5. Recorte un orificio adecuado en el pasacables de goma. Deslice el pasacables por el cable.
6. Prepare los extremos del cable de potencia de entrada y de motor de la forma mostrada en la figura. **Nota:** La pantalla pelada se conecta a tierra a 360 grados. Marque el extremo del cable de la pantalla con colores verde y amarillo para indicar que es el cable de conexión a tierra.
7. Pase los cables a través de los orificios de la placa pasacables y coloque los pasacables en los orificios (el cable de motor a la derecha y el de potencia de entrada a la izquierda).
8. Conecte el cable de motor:
 - Conecte a tierra las pantallas de los cables a 360 grados bajo la abrazadera de conexión a tierra (8a).
 - Conecte la pantalla trenzada del cable al terminal de conexión a tierra (8b).
 - Conecte los conductores de fase del cable a los terminales T1/U, T2/V y T3/W. Apriete los tornillos con el par indicado en la figura (8c). **Nota:** Los conductores de fase (R8, R9) pueden extraerse.
9. Conecte los cables de potencia de entrada como en el paso 8. Utilice los terminales L1, L2 y L3.
10. **R8...R9:** Si instala en paralelo, instale la segunda pletina de conexión a tierra para los cables de potencia paralelos. Repita los pasos 5...9.
11. Instale la pletina de conexión a tierra de los cables de control.
12. Reinstale la cubierta protectora en los terminales de potencia.
13. Fije los cables fuera de la unidad de forma mecánica.
14. Conecte a tierra la pantalla del cable de motor en el extremo del motor. Para que las interferencias por radiofrecuencia sean mínimas, conecte a tierra la pantalla a 360 grados del cable de motor en la placa pasacables de la caja de terminales del motor.

R6-
R9

ES

Conecte los cables de control

Véase la figura *D* de la página 158. Muestra un ejemplo de un cable de señal analógica y un cable de señal digital. Realice las conexiones de acuerdo con la configuración predeterminada que esté utilizando. Las conexiones predeterminadas de la configuración por defecto de HVAC se muestran en el apartado *Conexiones de I/O por defecto* de la página 52.

Ejemplo de conexión de un cable de señal analógica:

1. Practique un orificio adecuado en el pasacables de goma y pase el cable a través de él. Pase el cable a través de un orificio de la placa pasacables y fije el pasacables en el orificio.
2. Conecte a tierra la pantalla exterior del cable a 360 grados bajo la abrazadera de conexión a tierra. Mantenga el cable apantallado lo más próximo posible a los terminales de la tarjeta de control. Para cables de señal analógica, conecte a tierra las pantallas del par de cables y el cable de conexión a tierra al terminal SCR1. Asegure los cables mecánicamente a las abrazaderas situadas debajo de la unidad de control.
3. Tienda el cable como se muestra en la figura.
4. Conecte los conductores a los terminales adecuados de la tarjeta de control y apriete con un par de 0,5 a 0,6 N·m (0,4 lbf·ft).
5. Ajuste todos los cables de control usando las abrazaderas de montaje de cables.
6. Coloque los restantes pasacables de goma en los orificios de la placa pasacables.

**R6-
R9****ES**

Conexiones de I/O por defecto

A continuación se muestran las conexiones de E/S predeterminadas de la configuración por defecto de HVAC.

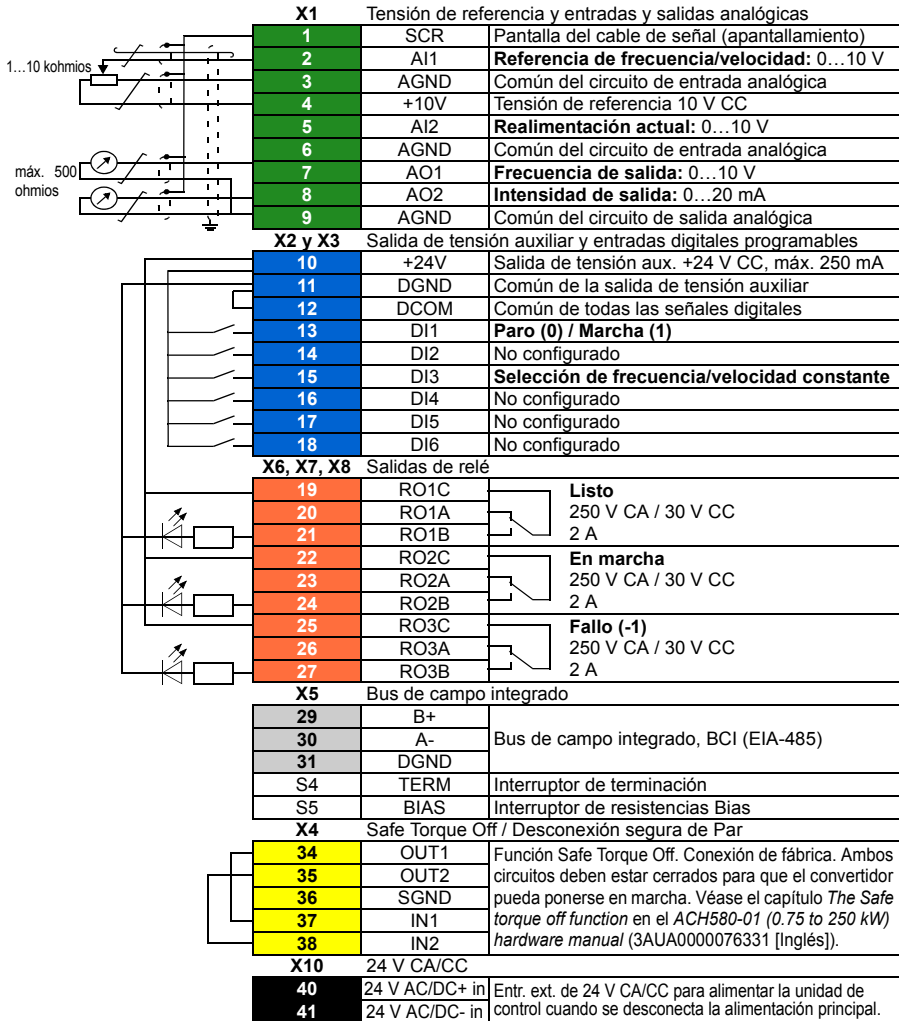
R6-
R9

ES

La capacidad de carga total de la salida de tensión auxiliar +24 V (X2:10) es de 6,0 W (250 mA/24 V CC).

Tamaños de cables: 0,14...2,5 mm² (26...16 AWG): Todos los terminales

Pares de apriete: 0,5...0,6 N·m (0,4 lbf·ft)

Si tiene módulos opcionales, instálelos

Véase el capítulo *Electrical installation* en el *ACH580-01 (0.75 to 250 kW) hardware manual* (3AUA0000076331 [Inglés]).

Instale las cubiertas y las placas laterales

Véase la figura *R6...R9 Figures E* en la página 159:

R6-
R9

IP21

1. Reinstale las placas laterales de la caja de entrada de cables. Apriete los tornillos de sujeción con un destornillador.
2. Deslice la cubierta de la caja de entrada de cables sobre el módulo desde abajo hasta que encaje.
3. Vuelva a colocar la cubierta del módulo. Apriete los dos tornillos de sujeción con un destornillador.

IP55

1. Vuelva a colocar la cubierta del módulo. Apriete los dos tornillos de sujeción con un destornillador.

ES

Para las instrucciones de puesta en marcha, véase el capítulo *ES – Guía rápida de puesta en marcha* en la página 181.

R6-
R9

ES

FI – R6...R9 Asennuksen pikaopas

Tässä oppaassa on taajuusmuuttajan lyhyet asennusohjeet. Täydelliset tiedot asennuksesta löytyvät oppaasta *ACH580-01 (0.75 to 250 kW) hardware manual* (3AUA0000076331, englanninkielinen). Ensimmäiseen käynnistykseen on annettu ohjeet luvussa *FI – Pika-aloitusopas* sivulla 187.

Voit lukea oppaita osoitteessa www.abb.com/drives/documents. Löydät oikean oppaan asiakirjanumerolla.

R6-
R9

Noudata turvaohjeita



VAROITUS! Noudata näitä ohjeita. Ohjeiden laiminlyönti voi aiheuttaa fyysisen vamman tai hengenvaaran tai vahingoittaa laitteistoa.

- Sähköasennustöitä saa tehdä vain pätevä sähköasentaja.
- Tee kaikki taajuusmuuttajan, moottorikaapelin ja moottorin asennus- ja huoltotyöt jännitteen ollessa katkaistuna. Jos taajuusmuuttaja on jo kytketty syöttöverkkoon, kytke se irti verkosta ja odota 5 minuuttia.
- Älä käsittele ohjauskaapeleita verkkojännitteen ollessa kytkettynä taajuusmuuttajaan tai ulkoisiin ohjauspiireihin.
- Nosta taajuusmuuttajaa nostokorvakkeista. Älä kallista taajuusmuuttajaa. Taajuusmuuttaja on raskas, ja sen painopiste on korkealla. Kaatuva taajuusmuuttaja saattaa aiheuttaa fyysisen vamman.
- Varmista, ettei poraus- tai hiomajäte pääse laitteen sisään asennuksen yhteydessä.
- Varmista, että taajuusmuuttajan alla oleva lattia ja seinä, johon taajuusmuuttaja on asennettu, ovat syttymättömiä.

FI

Tarkista, täytyykö kondensaattorit elvyttää

Jos taajuusmuuttajaan ei ole kytketty virtaa (eli se on ollut varastossa tai käyttämättömänä) yli vuoteen, kondensaattorit on elvytettävä.

Voit selvittää valmistusajankohdan sarjanumeron perusteella. Sarjanumero on taajuusmuuttajaan kiinnitetystä tyyppikilvessä. Sarjanumero on muotoa MYYWWRXXXX. YY ja WW ilmaisevat valmistusvuoden ja -viikon seuraavasti:

YY: 13, 14, 15,..., mikä tarkoittaa vuotta 2013, 2014, 2015,...

WW: 01, 02, 03,..., mikä tarkoittaa viikkoa 1, 2, 3,...

Lisätietoja kondensaattorien elvyttämisestä on *Converter module capacitor reforming instructions* -oppaassa (3BFE64059629, englanninkielinen), joka on saatavana osoitteesta www.abb.com/drives/documents.

Valitse tehokaapelit

Mitoita tehokaapelit taajuusmuuttajan tyyppikilvessä ilmoitetun nimellisvirran mukaan. Noudata paikallisia määräyksiä.

R6-
R9

Varmista jäähdytys

Lisätietoja lämpöhäviöstä on taulukossa I sivulla 13 (UL: taulukko II sivulla 13). Taajuusmuuttajan sallittu käyttölämpötila-alue on $-15...+50$ °C. Tiivistyminen ja huurtuminen eivät ole sallittuja. Lisätietoja käyttöympäristön lämpötilasta and derating on oppaan *ACH580-01 (0.75 to 250 kW) hardware manual* (3AUA0000076331, englanninkielinen) luvussa *Technical data*.

Suojaa taajuusmuuttaja ja syöttökaapeli

Tietoja sulakkeista on taulukoissa III, IV ja V sivuilla 14 ja 14.

Jos käytät gG-sulakkeita, varmista, että sulakkeen toiminta-aika on alle 0,5 sekuntia. Noudata paikallisia määräyksiä.

FI

Asenna taajuusmuuttaja seinälle



Varoitus! Taajuusmuuttajamoduuli on raskas (42–103 kg). Käytä sopivaa nostolaitetta. Älä nosta moduulia käsin. Varmista, että seinä ja kiinnitysvälineet kestävät painon.

Katso kuva *R6...R9 Figures A* sivulla 157.

Tarkista tehokaapelien ja moottorin eristys

Tarkista syöttökaapelin eristys paikallisten määräysten mukaisesti ennen kaapelin kytkemistä taajuusmuuttajaan.

Katso kuva [B](#) sivulla [157](#).

1. Tarkista moottorikaapelin ja moottorin eristys ennen niiden kytkemistä taajuusmuuttajaan. Mittaa vaihejohtimien väliset eristysvastukset sekä kunkin vaihejohtimen ja suojamaajohtimen (PE) välinen eristysvastus 1 000 V DC:n mittausjännitteellä. Tyyppillisen moottorin eristysvastuksen tulee olla yli 100 megaohmia (ohjearvo lämpötilassa 25 °C). Lisätietoja moottorien eristysvastuksista on moottorin valmistajan ohjeissa.

R6-
R9

Huomaa: Moottorin kotelon sisällä oleva kosteus pienentää eristysvastusta. Jos epäilet, että kotelon sisällä on kosteutta, kuivata moottori ja toista mittaus.

Tarkista yhteensopivuus maadoittamattomien IT-verkkojen ja epäsymmetrisesti maadoitettujen TN-verkkojen kanssa

■ EMC-suodin

Sisäinen EMC-suodin ei sovellu käytettäväksi maadoittamattomassa IT-verkossa tai epäsymmetrisesti maadoitetussa TN-verkossa. Kytke EMC-suodin irti, ennen kuin kytket taajuusmuuttajan syöttöverkkoon. Katso taulukko sivulla [58](#).

FI

 **VAROITUS!** Älä asenna sisäisellä EMC-suotimella varustettua taajuusmuuttajaa IT-verkkoon (maadoittamaton tai suurohmisesti [yli 30 ohmia] maadoitettu verkko), koska tällöin järjestelmä kytkeytyy maapotentiaaliin taajuusmuuttajan EMC-suotimen kondensaattorien kautta. Tämä voi aiheuttaa vaaratilanteen tai vahingoittaa taajuusmuuttajaa.

Älä asenna sisäisellä EMC-suotimella varustettua taajuusmuuttajaa epäsymmetrisesti maadoitettuun TN-verkkoon, koska tällöin taajuusmuuttaja vioittuu.

Huomautus: Kun sisäinen EMC-suodin on kytketty irti, taajuusmuuttajan EMC-yhteensopivuus on merkittävästi heikentynyt.

■ Maajohtimen ja vaihejohtimen välinen varistori

Maajohtimen ja vaihejohtimen välistä varistoria ei voi käyttää maadoittamattomassa IT-verkossa. Kytke varistori irti, ennen kuin kytket taajuusmuuttajan syöttöverkkoon. Katso taulukko sivulla [58](#).



VAROITUS! Jos taajuusmuuttaja, johon on kytketty maajohtimen ja vaihejohtimen välinen varistori, liitetään IT-verkkoon (maadoittamattomaan verkkoon tai suurohmisesti [yli 30 ohmia] maadoitettuun verkkoon), varistoripiiri saattaa vahingoittua.

R6-R9

Katso alla olevasta taulukosta, onko EMC-suodin (EMC) tai maajohtimen ja vaihejohtimen välinen varistori (VAR) kytkettävä irti. Irtykkyttämiseen on ohjeita sivulla 59.

Runkokoot	EMC-suodin (EMC)	Maajohtimen ja vaihejohtimen välinen varistori (VAR)	Symmetrisesti maadoitetut TN-verkot (TN-S-verkot) ¹	Epäsymmetrisesti maadoitetut TN-verkot ²	IT-verkot (maadoittamattomat tai suurohmisesti maadoitetut [>30 ohmia]) ³
R6...R9	EMC (2 ruuvia)	-	Älä kytke irti	Kytke irti	Kytke irti
	-	VAR (1 ruuvi)	Älä kytke irti	Älä kytke irti	Kytke irti

FI

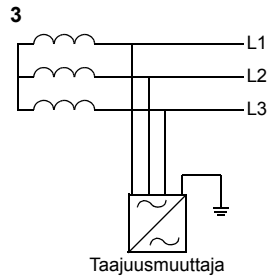
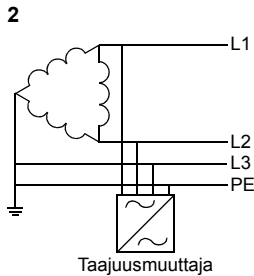
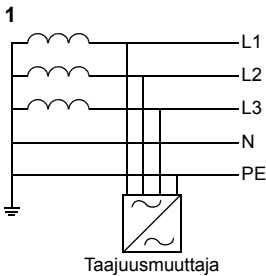

■ Kytke EMC-suodin tai maajohtimen ja vaihejohtimen välinen varistori tarvittaessa irti

Irrota sisäinen EMC-suodin tai maajohtimen ja vaihejohtimen välinen varistori tarvittaessa seuraavasti:

1. Katkaise taajuusmuuttajasta virta.
2. Avaa etukansi, jos se ei jo ole auki. Katso vaiheet 5, IP21 ja 5, IP55 kuvassa [R6...R9 Figures A](#) sivulla [157](#).
3. Kytke sisäinen EMC-suodin irti irrottamalla kaksi EMC-ruuvia.
4. Kytke maajohtimen ja vaihejohtimen välinen varistori irti irrottamalla varistorin ruuvi.

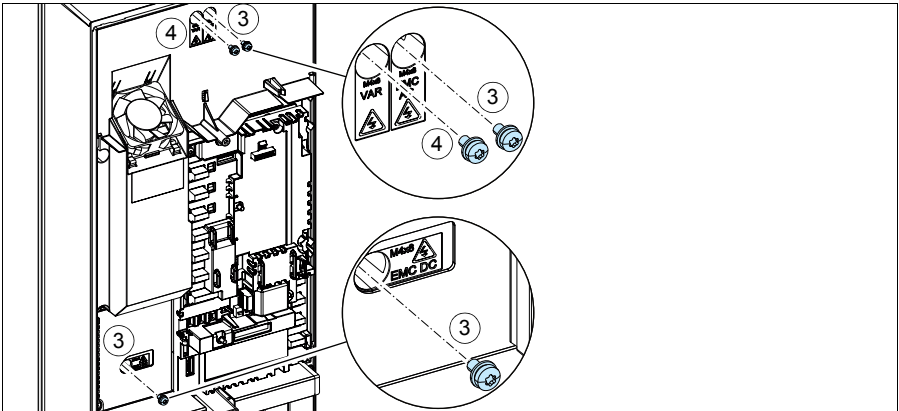
R6-
R9

FI

Kytke tehokaapelit

Katso kuva C sivulla 157. Käytä suojattua symmetristä moottorikaapelia. Jos kaapelin suojavaippa on taajuusmuuttajan tai moottorin ainoa PE-johdin, varmista, että sillä on riittävä johtavuus suojavaadoitusta varten.

1. Kiinnitä oikeankielinen jäännösjännitteen varoitustarra ohjauskortin viereen.
- R6-
R9 2. Irrota kaapelin läpivientikotelon sivulevyt: Löysää kiinnitysruuvit ja vedä seinät ulos.
3. Irrota suoja tehokaapelien liittimistä vapauttamalla sivulla olevat pidikkeet ruuvitalalla ja vetämällä suoja ulos.
4. Leikkaa aukot asennettaville kaapeleille.
5. Leikkaa kumitiivisteeseen sopivankokoinen reikä. Liu'uta tiiviste kaapelin päälle.
6. Valmistele syöttö- ja moottorikaapelin päät kuvassa esitetyllä tavalla. **Huomaa:** Paljas vaippa maadoitetaan 360 astetta. Merkitse suojavaipasta tehty punos PE-johtimeksi keltavihreällä värillä.
7. Liu'uta kaapelit pohjalevyn reikien läpi ja kiinnitä tiivisteet reikiin (moottorikaapeli oikeanpuoleiseen ja syöttökaapeli vasemmanpuoleiseen).
8. Kytke moottorikaapeli:
 - Maadoita suojavaippa 360 astetta maadoituskiinnikkeen alta (8a).
 - Kytke kaapelin kierretty suojavaippa maadoitusliittimeen (8b).
 - Kytke kaapelin vaihejohtimet liittimiin T1/U, T2/V ja T3/W. Kiristä ruuvit kuvassa (8c) annettuun momenttiin. **Huomaa:** Vaihejohtimet (R8, R9) ovat irrotettavia.
9. Kytke syöttökaapeli vaiheessa 8 kuvatulla tavalla. Käytä liittimiä L1, L2 ja L3.
10. R8...R9: Jos kyseessä on rinnakkaisasennus, asenna toinen maadoitushylly rinnakkaisia tehokaapeleita varten. Toista vaiheet 5...9.
11. Asenna ohjauskaapeleiden maadoitushylly.
12. Asenna teholiittimien suoja takaisin paikalleen.
13. Kiinnitä kaapelit yksikön ulkopuolella mekaanisesti.
14. Maadoita moottorikaapelin suojavaippa moottorin päästä. Vähennä EMC-häiriöitä maadoittamalla moottorikaapelin suojavaippa 360 astetta moottorin kytkentäkotelon läpiviennissä.

Kytke ohjauskaapelit

Katso kuva [D](#) sivulla [158](#). Kuvassa näkyy esimerkki yhdestä analogia- ja yhdestä digitaalisignaalkaapelista. Tee kytkennät käytössä olevan oletuskokoonpanon mukaisesti. HVAC-oletuskokoonpanon oletuskytkennät on esitetty kohdassa [Oletusarvoiset I/O-kytkennät](#) sivulla [62](#).

Esimerkki analogiasignaalkaapelin kytkemisestä:

1. Leikkaa kumitiivisteeseen sopivan kokoinen reikä ja liu'uta kumitiiviste kaapeliin. Vie kaapeli pohjalevyssä olevan reiän läpi ja kiinnitä tiiviste reikään.
2. Maadoita kaapelin kuorittu ulompi suojavaippa 360 astetta maadoitusliittimen alta. Pidä kaapeli muutoin kuorimattomana niin lähelle ohjauskortin liittimiä kuin mahdollista. Maadoita myös analogiasignaalkaapelien parikaapelin suojavaipat ja maadoitusjohdin SCR1-liittimen kohdalla. Kiinnitä kaapelit mekaanisesti ohjauskortin alla oleviin kiinnikkeisiin.
3. Reititä kaapeli kuvassa esitetyllä tavalla.
4. Kytke johtimet oikeisiin ohjauskortin liittimiin ja kiristä momenttiin 0,5...0,6 Nm.
5. Sido kaikki ohjauskaapelit sidontakiinnikkeisiin.
6. Pane käyttämättömät kumitiivisteet läpivientilevyn reikiin.

**R6-
R9****FI**

Oletusarvoiset I/O-kytkennät

Alla on esitetty HVAC-oletuskokoonpanon oletusarvoiset I/O-kytkennät.

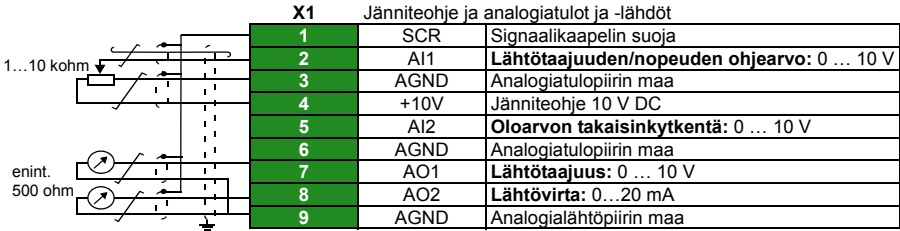
R6-
R9enint.
500 ohm

FI

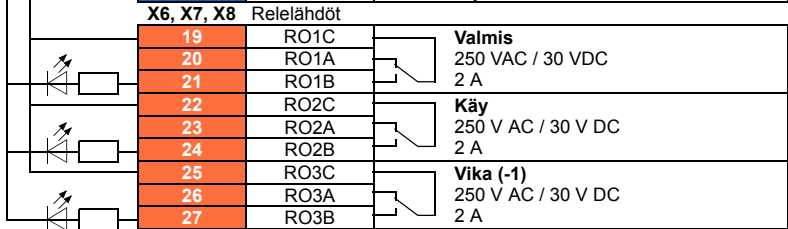

X5		Sisäänrakennettu kenttäväylä
29	B+	Sisäänrakennettu kenttäväylä, EFB (EIA-485)
30	A-	
31	DGND	
S4	TERM	Päätevastuksen kytkin
S5	BIAS	Esijännitysvastusten kytkin

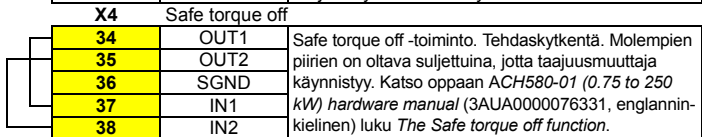

X10		24 V AC/DC
40	24 V AC/DC+ in	Ulk. 24V:n AC/DC-tulo ohjausyksikön virransyöttöön, kun verkkosyöttö on katkaistu.
41	24 V AC/DC- in	

Apujännitelähdön +24 V (X2:10) kokonaiskuormitettavuus on 6,0 W (250 mA / 24 V DC).

Johdinkoot: 0,14...2,5 mm²(26...16 AWG): kaikki liittimet

Kiristysmomentit: 0,5...0,6 Nm

Asenna mahdolliset lisävarustemoduulit

Katso oppaan *ACH580-01 (0.75 to 250 kW) hardware manual* (3AJUA0000076331, englanninkielinen) luku *Electrical installation*.

Asenna sivulevyt ja kannet

Katso kuva [R6...R9 Figures E](#) sivulla [159](#).

**R6-
R9**

IP21

1. Asenna kaapelin läpivientikotelon sivulevyt takaisin paikoilleen. Kiristä kiinnitysruuvit ruuvitaltalla.
2. Työnnä kaapelien läpivientikotelon kantta moduuliin altapäin, kunnes kansi napsahtaa paikalleen.
3. Asenna moduulin kansi takaisin paikalleen. Kiristä kaksi kiinnitysruuvia ruuvitaltalla.

IP55

1. Asenna moduulin kansi takaisin paikalleen. Kiristä kaksi kiinnitysruuvia ruuvitaltalla.

Ensimmäiseen käynnistykseen on annettu ohjeet luvussa [FI – Pika-aloitusopas](#) sivulla [187](#).

FI

R6-
R9

FI

FR – Guide d'installation R6...R9

Ce guide vous explique brièvement comment installer le variateur. Pour une présentation détaillée de l'installation, cf. *Manuel d'installation ACH580-01 (0,75 à 250 kW)*. Pour les consignes de mise en route, cf. chapitre *FR – Guide de mise en route* page 193.

Pour consulter un manuel, rendez-vous à l'adresse www.abb.com/drives/documents et recherchez le numéro du document souhaité.

R6-
R9

Consignes de sécurité



ATTENTION ! Vous devez suivre les consignes de sécurité à la lettre. Leur non-respect est susceptible de provoquer des blessures graves, voire mortelles, ou des dégâts matériels.

- Seul un électricien qualifié est autorisé à effectuer les raccordements électriques.
- N'intervenez jamais sur le variateur, le moteur ou son câblage sous tension. S'il est déjà raccordé au réseau, vous devez attendre 5 minutes après sectionnement de l'alimentation avant d'intervenir.
- Vous ne devez pas intervenir sur les câbles de commande lorsque le variateur ou les circuits de commande externes sont sous tension.
- Soulevez le variateur à l'aide des anneaux de levage. Vous ne devez pas pencher le variateur. Il est lourd et son centre de gravité est élevé. Un appareil qui bascule peut provoquer des blessures graves.
- En cas de perçage ou de rectification d'un élément, évitez toute pénétration de débris dans le variateur.
- Assurez-vous que le sol sous le variateur ainsi que la paroi de fixation sont en matériau ininflammable.

FR

Vérification des condensateurs

Si le variateur est resté plus d'un an sans être mis sous tension (en stockage ou non utilisé), vous devez réactiver les condensateurs.

Pour connaître la date de fabrication, consultez le numéro de série, qui se trouve sur la plaque signalétique de l'appareil. Le numéro de série est au format MAASSRXXXX, avec AA et SS indiquant respectivement l'année et la semaine de fabrication :

AA : 13, 14, 15, ... = 2013, 2014, 2015, ...

SS : 01, 02, 03, ... = semaine 1, semaine 2, semaine 3, ...

Pour la procédure de réactivation, cf. document anglais *Converter module capacitor reforming instructions* (3BFE64059629), disponible sur Internet à l'adresse www.abb.com/drives/documents.

Sélection des câbles de puissance

Les câbles de puissance doivent être dimensionnés en fonction de la réglementation locale pour supporter le courant nominal indiqué sur la plaque signalétique du variateur.

R6-
R9

Refroidissement

Cf. tableau / page 13 (UL : tableau // page 13) pour les valeurs de dissipation thermique. La plage de température de fonctionnement admissible va de -15 à +50 °C (de +5 à +122 °F). Condensation ou givre interdits. Pour en savoir plus sur la température ambiante et le déclassement, cf. chapitre *Caractéristiques techniques* du *Manuel d'installation ACH580-01 (0,75 à 250 kW)*.

Protection du variateur et du câble réseau

Cf. tableaux III, IV et V pages 14 et 14 pour les fusibles.

Si vous prévoyez d'utiliser des fusibles gG, vérifiez que le temps de manœuvre du fusible est inférieur à 0,5 seconde. Respectez la réglementation locale.

Montage mural du variateur

FR



Attention ! Le module variateur est lourd (entre 42 et 103 kg / entre 93 et 227 lb). Utilisez un dispositif de levage approprié. Tout levage manuel est exclus. Assurez-vous que la paroi et le dispositif de fixation supportent le poids de l'appareil.

Cf. figure R6...R9 Figures A page 157.

Mesure de la résistance d'isolement des câbles de puissance et du moteur

Mesurez la résistance d'isolement du câble réseau avant de le brancher sur le variateur conformément à la réglementation en vigueur.

Cf. figure *B* page 157.

1. Mesurez la résistance d'isolement du moteur et du câble moteur avant de le brancher sur le variateur. Mesurez la résistance d'isolement du câble moteur entre chaque phase ainsi qu'entre chaque phase et le conducteur PE du moteur avec une tension de mesure de 1000 Vc.c. Les valeurs mesurées sur un moteur typique doivent être supérieures à 100 Mohm (valeur de référence à 25 °C ou 77 °F). Pour la résistance d'isolement des moteurs, consultez les consignes du fabricant.

N.B. : La présence d'humidité à l'intérieur de l'enveloppe du moteur réduit sa résistance d'isolement. Si vous pensez que le moteur est humide, séchez-le et reprenez la mesure.

Vérification de la compatibilité avec les réseaux en schéma IT (neutre isolé ou impédant) ou TN (mise à la terre asymétrique)

■ Filtre RFI

Le filtre RFI interne ne convient ni à un réseau en schéma IT (neutre isolé ou impédant), ni à un réseau en schéma TN (mise à la terre asymétrique). Vous devez débrancher le filtre RFI avant de raccorder le variateur au réseau. Cf. tableau page 68.



ATTENTION ! Il est interdit de raccorder un variateur équipé du filtre RFI interne sur un réseau en schéma IT (neutre isolé ou impédant) [plus de 30 ohm]. Sinon, le réseau est raccordé au potentiel de la terre par l'intermédiaire des condensateurs du filtre RFI, ce qui peut s'avérer dangereux ou endommager l'appareil.

Il est par ailleurs interdit de raccorder un variateur équipé d'un filtre RFI sur un réseau en schéma TN (mise à la terre asymétrique), ce qui l'endommagerait.

N.B. : Lorsque le filtre RFI interne est débranché, la compatibilité CEM du variateur diminue fortement.

■ Varistance phase-terre

La varistance phase-terre ne convient pas à une utilisation sur un réseau en schéma IT (neutre isolé ou impédant). Vous devez débrancher la varistance avant de raccorder le variateur au réseau. Cf. tableau page 68.

ATTENTION ! Il est interdit de raccorder un variateur équipé de la varistance phase-terre sur un réseau en schéma IT (neutre isolé ou impédant) [plus de 30 ohm] ou en schéma TN (mise à la terre asymétrique), car cela risquerait d'endommager le circuit des varistances.

R6-
R9

Vérifiez à l'aide du tableau ci-dessous si vous devez débrancher le filtre RFI (EMC) ou la varistance phase-terre (VAR). Pour les consignes, cf. page 69.

Tailles	Filtre RFI CEM	Varistance phase-terre (VAR)	Réseau en schéma TN symétrique (TN-S) ¹	Réseaux en schéma TN asymétrique ²	Réseau en schéma IT (neutre isolé ou impédant [> 30 ohms]) ³
R6...R9	CEM 2 vis)	-	Ne pas déconnecter	Déconnecter	Déconnecter
	-	VAR 1 vis	Ne pas déconnecter	Ne pas déconnecter	Déconnecter

1

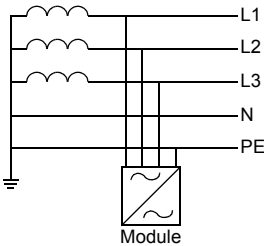

2

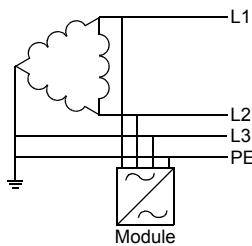

3

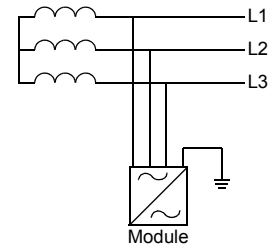

FR

■ Déconnexion du filtre RFI ou de la varistance phase-terre si requis

Pour déconnecter le filtre RFI ou la varistance phase-terre si nécessaire, procédez comme suit :

1. Mettez le variateur hors tension.
2. Ouvrez le capot supérieur si tel n'est pas déjà le cas ; cf. étape 5 pour les appareils IP21 et IP55 à la figure *R6...R9 Figures A* page 157.
3. Débranchez le filtre RFI interne en retirant les deux vis EMC.
4. Débranchez la varistance phase-terre en retirant la vis VAR.

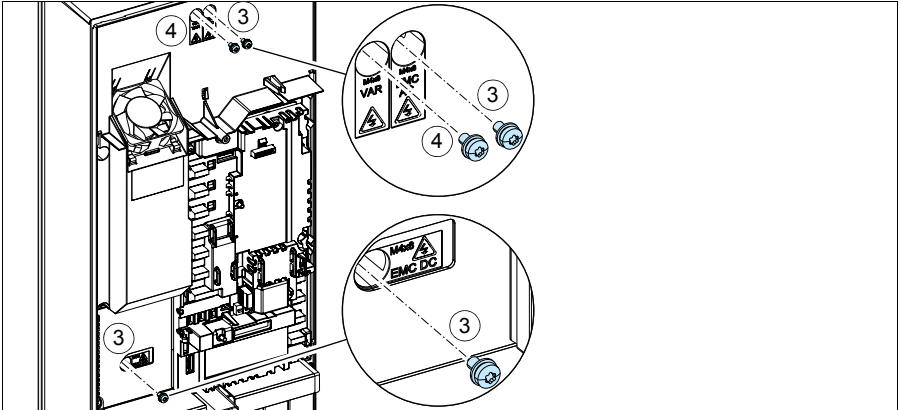
R6-
R9

FR

Raccordement des câbles de puissance

Cf. figure C page 157. Utilisez un câble moteur symétrique blindé. Si le blindage du câble constitue le seul conducteur PE du variateur ou du moteur, vérifiez que sa conductivité est suffisante pour assurer la protection.

1. Vous devez fixer une étiquette de mise en garde contre les tensions résiduelles dans votre langue à côté de la carte de commande.
2. Retirez les plaques latérales du boîtier d'entrée des câbles. Desserrez les vis de fixation et faites glisser la paroi.
3. Ôtez la protection des bornes de puissance en enfonçant les clips latéraux avec un tournevis pour sortir la protection.
4. Percez les ouvertures pour le passage des câbles.
5. Découpez un trou de diamètre adéquat dans le passe-câbles en caoutchouc pour le glisser sur le câble.
6. Préparez les extrémités des câbles d'alimentation et moteur comme l'illustre la figure. **N.B.** : Vous devrez effectuer une reprise de masse sur 360° du blindage nu. Marquez la queue de cochon du blindage en jaune et vert pour indiquer qu'il s'agit du conducteur PE.
7. Faites passer les câbles dans les perçages de la plaque du fond et fixez les passe-câbles dessus (câble moteur à droite et câble réseau à gauche).
8. Raccordez le câble moteur :
 - Effectuez une reprise de masse sur 360° du blindage sous le collier de terre (8a).
 - Raccordez le blindage torsadé du câble à la borne de terre (8b).
 - Raccordez les conducteurs de phase du câble aux bornes T1/U, T2/V et T3/W. Serrez les vis au couple indiqué à la figure 8c. **N.B.** : Les conducteurs de phase (R8, R9) sont débroschables.
9. Raccordez le câble réseau comme à l'étape 8. Utilisez les bornes L1, L2 et L3.
10. R8...R9 : En cas d'installation en parallèle, montez la deuxième platine de mise à la terre pour les câbles de puissance parallèles. Reproduisez les étapes 5 à 9.
11. Montez la platine de mise à la terre des câbles de commande.
12. Remplacez la protection des bornes de puissance.
13. Fixez mécaniquement les câbles à l'extérieur du variateur.
14. Mettez à la terre le blindage du câble moteur du côté moteur. Pour minimiser les perturbations HF, effectuez une reprise de masse sur 360° du blindage du câble moteur en entrée de la boîte à bornes du moteur.

R6-
R9

FR

Raccordement des câbles de commande

Cf. figure [D](#) page [158](#) pour un exemple avec un câble de signaux analogiques et un câble de signaux logiques. Raccordez les câbles selon le pré-réglages du macroprogramme. Les pré-réglages usine du macroprogramme Standard HVAC sont indiqués à la section [Raccordement des signaux d'E/S \(pré-réglages\)](#) page [72](#).

Raccordement d'un câble de signaux analogiques :

1. Découpez un trou de diamètre adéquat dans le passe-câbles en caoutchouc pour le glisser sur le câble. Insérez le câble dans le trou de la plaque inférieure et fixez-y le passe-câbles.
2. Effectuez une reprise de masse sur 360° du blindage externe sous le collier de terre. Le câble ne doit pas être dénudé et doit cheminer aussi près que possible des bornes de la carte de commande. Pour les câbles de signaux analogiques, vous devez aussi mettre à la terre les blindages doubles et le fil de terre sur la borne SCR1. Fixez mécaniquement les câbles aux colliers situés sous la carte de commande.
3. Les câbles doivent cheminer comme indiqué sur la figure.
4. Raccordez les conducteurs aux bornes appropriées de la carte de commande et serrez à 0,5...0,6 N·m (0.4 lbf·ft).
5. Fixez tous les câbles de commande sur les colliers de câble fournis.
6. Placez les passe-câbles en caoutchouc non utilisés sur les perçages de la plaque passe-câbles.

R6-
R9

FR

Raccordement des signaux d'E/S (préréglages)

Le schéma suivant illustre les préréglages usine des signaux d'E/S du programme de commande HVAC.

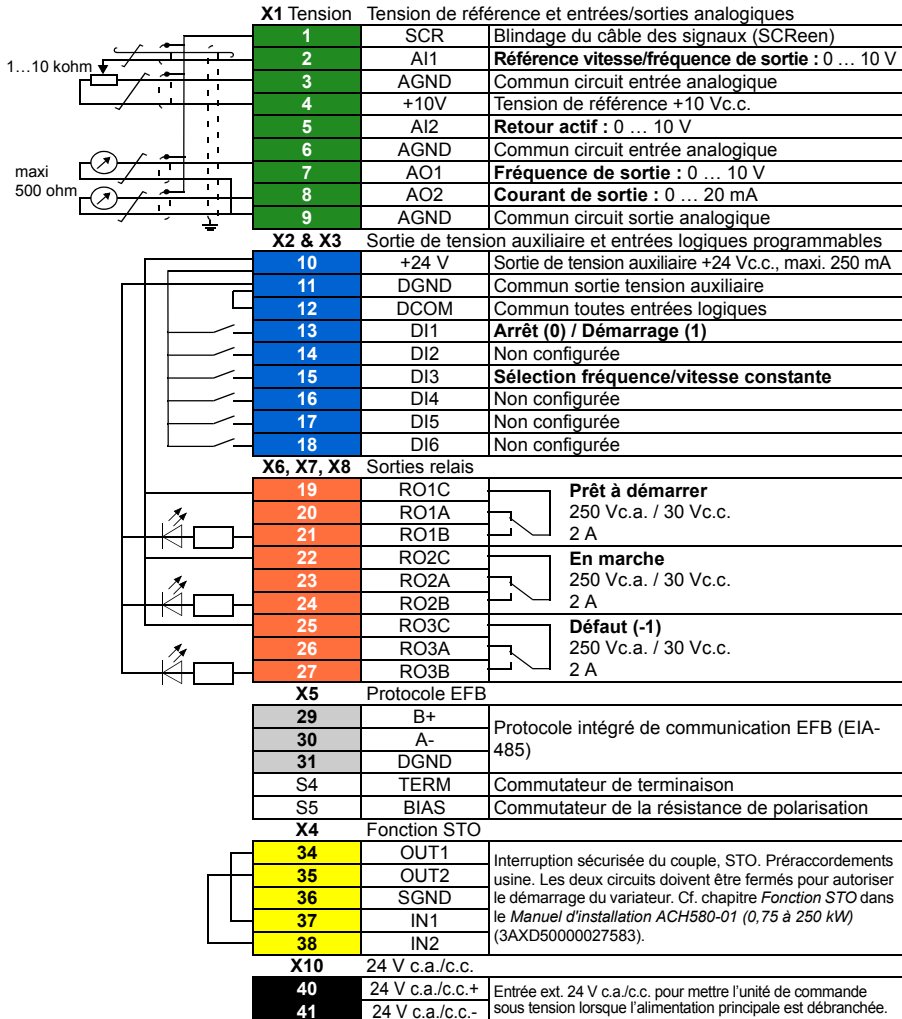
R6-
R9

FR

La capacité de charge totale de la sortie en tension auxiliaire +24V (X2:10) est 6,0 W (250 mA / 24 V c.c.).

Section des câbles : 0,14 ... 2,5 mm² (26...16 AWG) : toutes les bornes

Couples de serrage : 0,5...0,6 N·m (0.4 lbf·ft)

Installation des modules optionnels (si présents)

Cf. chapitre *Raccordements* dans le *Manuel d'installation ACH580-01 (0,75 à 250 kW)* (3AXD50000027583).

Montage des capots et des plaques latérales

Cf. figure *R6...R9 Figures E* page 159

R6-
R9

IP21

1. Remontez les plaques latérales du boîtier d'entrée des câbles. Serrez les vis restantes à l'aide d'un tournevis.
2. Faites glisser le capot du boîtier d'entrée des câbles de bas en haut le long du module jusqu'à ce qu'il s'enclenche.
3. Remontez le capot du module. Serrez les deux vis restantes à l'aide d'un tournevis.

IP55

1. Remontez le capot du module. Serrez les deux vis restantes à l'aide d'un tournevis.

Pour les consignes de mise en route, cf. chapitre *FR – Guide de mise en route* page 193.

FR

R6-
R9

FR

IT – Guida rapida all'installazione R6...R9

Questa guida descrive brevemente la procedura di installazione del convertitore di frequenza. Per le informazioni complete sull'installazione, vedere *ACH580-01 (0.75 to 250 kW) hardware manual* (3AUA0000076331 [inglese]). Per le istruzioni di avviamento, vedere il capitolo *IT – Guida rapida all'avviamento* a pag. 199.

Per consultare i manuali, visitare www.abb.com/drives/documents e cercare il numero di documento.

R6-
R9

Rispettare le norme di sicurezza



AVVERTENZA! Rispettare le seguenti norme di sicurezza. La mancata osservanza di queste norme può mettere in pericolo l'incolumità delle persone, con rischio di morte, e danneggiare le apparecchiature:

- L'installazione elettrica deve essere eseguita esclusivamente da elettricisti qualificati.
- Non operare sul convertitore, sul cavo motore o sul motore quando è inserita l'alimentazione. Se il convertitore è già collegato all'alimentazione, disinserirla e attendere 5 minuti.
- Non lavorare sui cavi di controllo quando il convertitore o i circuiti di controllo esterni sono alimentati.
- Sollevare il convertitore utilizzando i golfari presenti sull'unità. Non inclinare il convertitore. Il convertitore è pesante e ha il baricentro alto. Se l'unità si ribalta può causare infortuni.
- Assicurarsi che i detriti generati da forature e smerigliature non si infiltrino nell'unità durante l'installazione.
- Assicurarsi che il pavimento sotto il convertitore e la parete dove è installato il convertitore siano non infiammabili.

IT

Ricondizionamento dei condensatori

Se il convertitore è fermo da oltre un anno (perché è rimasto inutilizzato oppure in magazzino), è necessario ricondizionare i condensatori.

La data di fabbricazione si legge dal numero di serie riportato sull'etichetta identificativa del convertitore. Il formato del numero di serie è MYYWWRXXXX. YY e WW indicano rispettivamente l'anno e la settimana di produzione, nel modo seguente:

YY: 13, 14, 15, ... per 2013, 2014, 2015, ...

WW: 01, 02, 03, ... per settimana 1, settimana 2, settimana 3, ...

Per informazioni sul ricondizionamento dei condensatori, vedere *Converter module capacitor reforming instructions* (3BFE64059629 [inglese]), disponibile in Internet al sito www.abb.com/drives/documents.

Selezione dei cavi di potenza

Dimensionare i cavi di potenza in base alle normative locali. I cavi devono essere adatti a condurre la corrente nominale indicata sull'etichetta identificativa del convertitore.

R6-
R9

Raffreddamento

Vedere la tabella *I* a pag. 13 (UL: tabella *II* a pag. 13) per la dissipazione di calore. Il range di temperatura operativa del convertitore è -15...+50 °C (+5...+122 °F). Non sono ammessi ghiaccio e condensa. Per ulteriori informazioni sulla temperatura ambiente e il declassamento, vedere il capitolo *Technical data (Dati tecnici)* in *ACH580-01 (0.75 to 250 kW) hardware manual* (3AUA0000076331 [inglese]).

Protezione del convertitore e del cavo di alimentazione di ingresso

Vedere le tabelle *III*, *IV* e *V* alle pagg. 14 e 14 per i dati relativi ai fusibili.

Se si utilizzano fusibili gG, verificare che il tempo di intervento del fusibile sia inferiore a 0.5 secondi. Attenersi alle normative locali.

Montaggio del convertitore di frequenza a parete

IT



Avvertenza! Il modulo convertitore è pesante (42...103 kg / 93...227 lb).

Sollevarlo con un'attrezzatura idonea. Non sollevare il modulo manualmente. Assicurarsi che la parete e i dispositivi di fissaggio siano in grado di sostenere il peso.

Vedere la figura *R6...R9 Figures A* a pag. 157.

Controllo dell'isolamento dei cavi di potenza e del cavo motore

Verificare che l'isolamento del cavo di ingresso sia conforme alle normative locali prima di collegarlo al convertitore di frequenza.

Vedere la figura **B** a pag. **157**.

1. Verificare l'isolamento del cavo motore e del motore prima di effettuare il collegamento al convertitore di frequenza. Misurare la resistenza di isolamento tra ogni conduttore di fase e poi tra ogni conduttore di fase e il conduttore di protezione di terra (PE) con una tensione di misura di 1000 Vcc. La resistenza di isolamento di un motore tipico deve essere superiore a 100 Mohm (valore di riferimento a 25 °C o 77 °F). Per la resistenza di isolamento dei motori, consultare le istruzioni del produttore.

Nota: la presenza di umidità all'interno dell'alloggiamento del motore riduce la resistenza di isolamento. In caso di umidità, asciugare il motore e ripetere la misurazione.

Verifica della compatibilità con sistemi IT (senza messa a terra) e sistemi TN con una fase a terra

■ Filtro EMC

Il filtro EMC interno non deve essere utilizzato con sistemi IT (senza messa a terra) e sistemi TN con una fase a terra. Scollegare il filtro EMC prima di collegare il convertitore di frequenza alla rete di alimentazione. Vedere la tabella a pag. **78**.

 **AVVERTENZA!** Non installare il convertitore di frequenza con il filtro EMC interno collegato in un sistema IT (un sistema di alimentazione senza messa a terra o con messa a terra ad alta resistenza [superiore a 30 ohm]), altrimenti il sistema risulterà collegato al potenziale di terra attraverso i condensatori del filtro EMC. Questo può determinare una situazione di pericolo o danneggiare l'unità.

Non installare un convertitore con filtro EMC interno collegato in un sistema TN con una fase a terra, altrimenti il convertitore verrà danneggiato.

Nota: quando il filtro EMC interno è scollegato, la compatibilità elettromagnetica del convertitore risulta notevolmente ridotta.

■ Varistore fase-terra

Il varistore fase-terra non è adatto all'uso in sistemi IT (senza messa a terra). Scollegare il varistore fase-terra prima di collegare il convertitore di frequenza alla rete di alimentazione. Vedere la tabella a pag. **78**.

AVVERTENZA! Non installare il convertitore di frequenza con il varistore fase-terra collegato in sistemi IT (sistemi di alimentazione senza messa a terra o con messa a terra ad alta resistenza [oltre 30 ohm]) perché così facendo si può danneggiare il circuito del varistore.

R6-
R9

Con l'aiuto della tabella seguente, controllare se il filtro EMC o il varistore fase-terra (VAR) devono essere scollegati. Per le istruzioni su come procedere, vedere pag. 79.

Telai	Filtro EMC (EMC)	Varistore fase-terra (VAR)	Sistemi TN con messa a terra simmetrica (sistemi TN-S) ¹	Sistemi TN con una fase a terra ²	Sistemi IT (senza messa a terra o con messa a terra ad alta resistenza [$>30\text{ ohm}$]) ³
R6...R9	EMC (2 viti)	-	Non scollegare	Scollegare	Scollegare
	-	VAR (1 vite)	Non scollegare	Non scollegare	Scollegare

1

Convertitore

2

Convertitore

3

Convertitore

IT

■ Scollegamento del filtro EMC o del varistore fase-terra (quando necessario)

Per scollegare il filtro EMC interno o il varistore fase-terra, se necessario, procedere come segue:

1. Spegnerne l'alimentazione del convertitore di frequenza.
2. Aprire il coperchio anteriore, se non è già aperto; vedere i punti 5, IP21 e 5, IP55 nella figura *R6...R9 Figures A* a pag. 157.
3. Scollegare il filtro EMC interno rimuovendo le due viti EMC.
4. Scollegare il varistore fase-terra rimuovendo la vite del varistore.

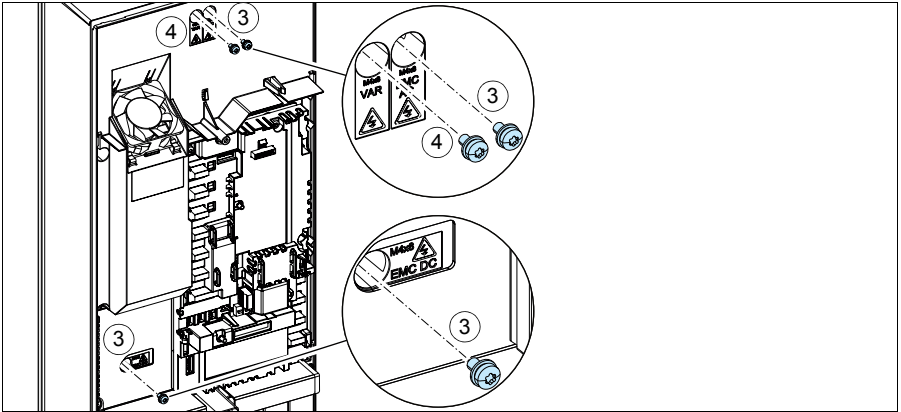
**R6-
R9****IT**

Collegamento dei cavi di alimentazione

Vedere la figura **C** a pag. **157**. Utilizzare un cavo schermato di tipo simmetrico per il motore. Se la schermatura del cavo è l'unico conduttore PE per convertitore e motore, assicurarsi che abbia una sezione adeguata per il circuito di terra.

1. Applicare l'adesivo con il messaggio di avvertenza per tensione residua (nella lingua locale) vicino alla scheda di controllo.
2. Rimuovere le piastre laterali della cassetta di ingresso dei cavi: allentare le viti di fermo ed estrarre le piastre.
3. Rimuovere la schermatura sui morsetti dei cavi di potenza sganciando le clip con un cacciavite e sollevandola.
4. Praticare i fori per l'ingresso dei cavi che saranno installati.
5. Tagliare un foro di dimensioni adeguate nel gommino. Far scivolare il gommino sul cavo.
6. Preparare le estremità del cavo di alimentazione e del cavo motore come illustrato nella figura. **Nota:** la schermatura dovrà essere messa a terra a 360°. Contrassegnare la treccia ottenuta con la schermatura come conduttore PE con i colori giallo e verde.
7. Far passare i cavi attraverso i fori della piastra inferiore e inserire i gommini nei fori (cavo motore a destra e cavo di alimentazione a sinistra).
8. Collegare il cavo motore:
 - Mettere a terra la schermatura a 360° sotto il morsetto di terra (8a).
 - Collegare la schermatura intrecciata del cavo al morsetto di terra (8b).
 - Collegare i conduttori di fase del cavo ai morsetti T1/U, T2/V e T3/W. Serrare le viti applicando le coppie indicate nella figura (8c). **Nota:** i conduttori di fase (R8, R9) sono remotabili.
9. Collegare il cavo di alimentazione di ingresso come spiegato al punto **8**. Utilizzare i morsetti L1, L2 e L3.
10. **R8...R9:** in caso di installazione parallela, installare la seconda piastra di messa a terra per i cavi di potenza paralleli. Ripetere i punti **5...9**.
11. Installare la piastra di messa a terra per i cavi di controllo.
12. Reinstallare la schermatura sui morsetti di potenza.
13. Assicurare meccanicamente i cavi all'esterno dell'unità.
14. Mettere a terra la schermatura del cavo del motore sul lato motore. Per ridurre al minimo le interferenze da radiofrequenza, mettere a terra la schermatura del cavo motore a 360° in corrispondenza della piastra passacavi della morsettiera del motore.

R6-
R9

IT

Collegamento dei cavi di controllo

Vedere la figura *D* a pag. 158. Mostra un esempio con un cavo dei segnali analogici e un cavo dei segnali digitali. Eseguire i collegamenti in base alla configurazione di default utilizzata. I collegamenti di default della configurazione HVAC di default sono illustrati nella sezione *Collegamenti di I/O di default* a pag. 82.

Esempio di collegamento del cavo dei segnali analogici:

1. Praticare un foro di dimensioni idonee nel gommino e fare scivolare il gommino sul cavo. Far passare il cavo attraverso un foro della piastra inferiore e inserire il gommino nel foro.
2. Mettere a terra la schermatura esterna spellata del cavo a 360° sotto il morsetto di terra. Il cavo non spellato deve rimanere il più possibile vicino ai morsetti della scheda di controllo. Per i cavi dei segnali analogici, mettere a terra anche le schermature dei doppini e il filo di terra in corrispondenza del morsetto SCR1. Fissare i cavi meccanicamente ai morsetti sotto la scheda di controllo.
3. Posare il cavo come mostrato nella figura.
4. Collegare i conduttori ai rispettivi morsetti della scheda di controllo e serrare applicando una coppia di 0.5...0.6 N·m (0.4 lbf·ft).
5. Fissare tutti i cavi di controllo alle apposite fascette.
6. Inserire i gommini inutilizzati nei fori della piastra passacavi.

**R6-
R9****IT**

Collegamenti di I/O di default

Di seguito sono mostrati i collegamenti di I/O di default della configurazione HVAC di default.

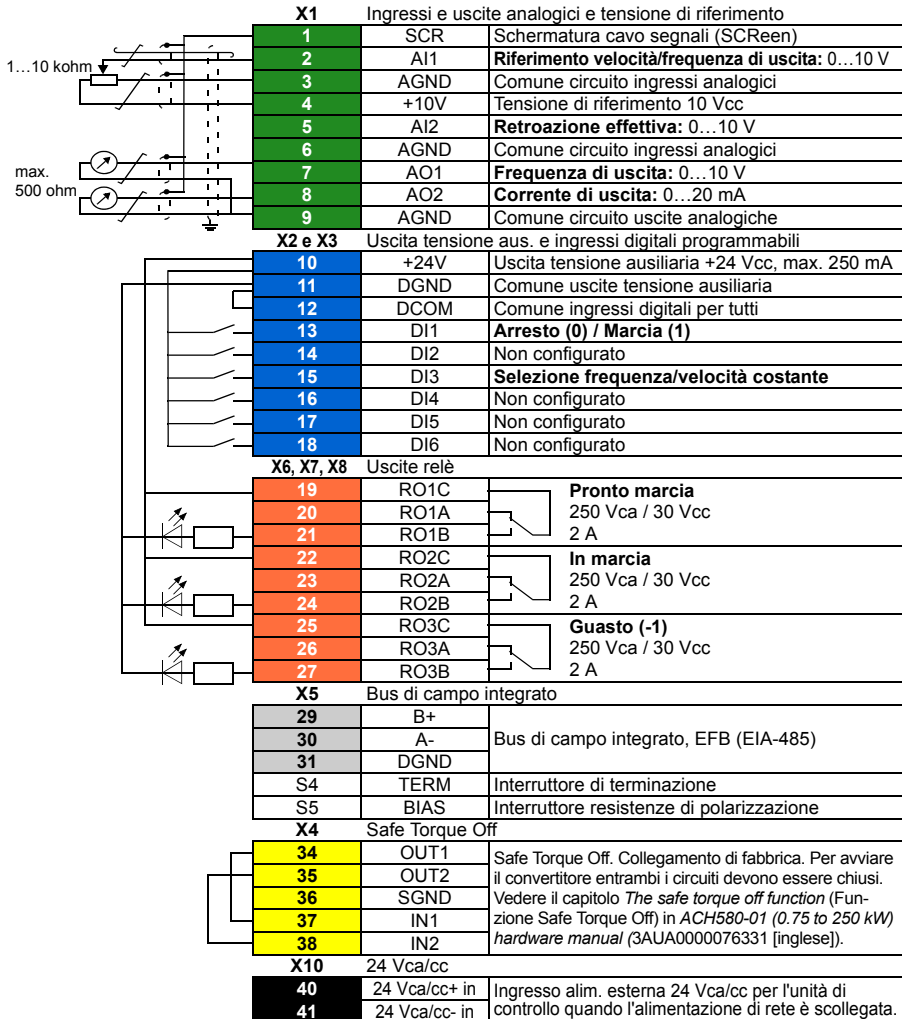
R6-
R9

IT

La capacità di carico totale dell'uscita della tensione ausiliaria +24V (X2:10) è 6.0 W (250 mA / 24 Vcc).

Dimensioni fili: 0.14...2.5 mm² (26...16 AWG); tutti i morsetti

Coppie di serraggio: 0.5...0.6 N·m (0.4 lbf·ft)

Installazione dei moduli opzionali, se presenti

Vedere il capitolo *Electrical installation* (Installazione elettrica) in *ACH580-01 (0.75 to 250 kW) hardware manual* (3AUA0000076331 [inglese]).

Installazione di piastre laterali e coperchi

Vedere la figura [R6...R9 Figures E](#) a pag. 159.

R6-
R9

IP21

1. Reinstallare le piastre laterali della cassetta di ingresso dei cavi. Serrare le viti di fermo con un cacciavite.
2. Inserire il coperchio della cassetta di ingresso cavi sul modulo, facendolo scorrere dal basso finché non si blocca con uno scatto.
3. Reinstallare il coperchio del modulo. Serrare le due viti di fermo con un cacciavite.

IP55

1. Reinstallare il coperchio del modulo. Serrare le due viti di fermo con un cacciavite.

Per le istruzioni di avviamento, vedere il capitolo [IT – Guida rapida all'avviamento](#) a pag. 199.

R6-
R9

IT

NL – R6...R9 Beknopte installatiegids

Deze gids geeft een beknopte beschrijving van het installeren van de omvormer. Zie voor volledige informatie over het installeren *ACH580-01 (0.75 to 250 kW) hardware manual* (3AUA0000076331 [Engels]). Zie voor opstart-instructies het hoofdstuk [NL – Beknopte opstartgids](#) op pagina 205.

Om een handleiding te lezen gaat u naar www.abb.com/drives/documents en zoekt u het documentnummer.

R6-
R9

Volg de veiligheidsvoorschriften



WAARSCHUWING! Volg deze instructies. Indien u deze negeert, kan dit lichamelijk letsel of de dood tot gevolg hebben, of er kan schade aan de apparatuur ontstaan:

- Als u geen gekwalificeerd elektricien bent, voer dan geen elektrisch installatiewerkzaamheden uit.
- Voer nooit werkzaamheden uit aan de omvormer, de motorkabel of de motor als ze onder spanning staan. Als de omvormer al is aangesloten op het voedingsnet, ontkoppelt u de omvormer en wacht u 5 minuten.
- Voer geen werkzaamheden uit aan de besturingskabels als de omvormer of externe besturingscircuits onder spanning staan.
- Gebruik de hijsogen van de omvormer bij het tillen van de omvormer. Kantel de omvormer niet. De omvormer is zwaar en het zwaartepunt ligt hoog. Een omvallende omvormer kan lichamelijk letsel veroorzaken.
- Zorg bij de installatie dat er geen boor- of slijpafval in de omvormer binnendringt.
- Zorg er voor dat de vloer onder de omvormer en de wand waaraan de omvormer is gemonteerd onbrandbaar zijn.

NL

Controleer of condensatoren opnieuw gevormed moeten worden

Als de omvormer langer dan een jaar niet ingeschakeld is (ofwel in opslag of ongebruikt), moet u de condensatoren opnieuw formeren.

U kunt de fabricagedatum bepalen uit het serienummer, dat op het typeplaatje, bevestigd aan de omvormer, te vinden is. Het serienummer heeft het formaat MYYWWRXXXX. YY en WW bepalen als volgt het jaar en de week van fabricage:

YY: 13, 14, 15, ... voor 2013, 2014, 2015, ...

WW: 01, 02, 03, ... voor week 1, week 2, week 3, ...

Zie, voor informatie over het opnieuw formeren van de condensatoren, *Converter module capacitor reforming instructions*(3BFE64059629 [Engels]), dat op internet te vinden is op www.abb.com/drives/documents.

Kies de vermogenskabels

Dimensioneer de vermogenskabels volgens de plaatselijke regelgeving om de nominale stroom te voeren die gegeven is op het typeplaatje van uw omvormer.

R6-
R9

Zorg voor de koeling

Zie tabel *I* op pagina *13* (UL: tabel *II* op pagina *13*) voor de warmteverliezen. Het toegestane bedrijfstemperatuurbereik van de omvormer is -15 tot +50 °C (+5 tot +122 °F). Er is geen condensatie of vorst toegestaan. Voor meer informatie over de omgevingstemperatuur en derating, zie het hoofdstuk *Technical data* in *ACH580-01 (0.75 to 250 kW) hardware manual* (3AUA0000076331 [Engels]).

Beveilig de omvormer en de voedingskabel

Zie tabel *III*, *IV* en *V* op pagina *14* en *14* voor de zekeringen.

Controleer, bij gebruik van gG-zekeringen, dat de responstijd van de zekering onder de 0,5 seconden ligt. Volg de plaatselijke bepalingen.

Installeer de omvormer aan de wand



Waarschuwing! De omvormermodule is zwaar (42 tot 103 kg / 93 tot 227 lb). Gebruik een geschikt hijs toestel. Til de module niet handmatig op. Zorg er voor dat de wand en de bevestigingsmaterialen het gewicht kunnen dragen.

NL

Zie figuur *R6...R9 Figures A* op pagina *157*.

Controleer de isolatie van de vermogenskabels en de motor

Controleer de isolatie van de ingangskabel volgens plaatselijke regelgeving alvorens deze aan te sluiten op de omvormer.

Zie figuur **B** op pagina **157**.

1. Controleer de isolatie van de motorkabel en motor alvorens deze aan te sluiten op de omvormer. Meet de isolatieweerstand tussen elke fasegeleider en daarna tussen elke fasegeleider en de veiligheidsaardegeleider door een meetspanning van 1000 V DC te gebruiken. De isolatieweerstand van een typische motor moet hoger zijn dan 100 Mohm (referentiewaarde bij 25 °C of 77 °F). Voor de isolatieweerstand van motors moet u de instructies van de fabrikant raadplegen.

R6-
R9

Opmerking: Vocht in de motorbehuizing zal de isolatieweerstand verlagen. Als u vocht vermoedt, moet u de motor drogen en de meting herhalen.

Controleer de compatibiliteit met IT (ongeaarde) en hoekgeaarde TN systemen

■ EMC-filter

Het interne EMC-filter is niet geschikt voor gebruik in een IT (ongeaard) systeem of een hoekgeaard TN-systeem. Ontkoppel het EMC-filter voordat u de omvormer aansluit op het voedingsnetwerk. Controleer de tabel op pagina **88**.



WAARSCHUWING! Installeer de omvormer niet met aangesloten intern EMC-filter bij installatie in een IT systeem (een niet-geaard vermogenssysteem of een hoogohmig geaard vermogenssysteem [meer dan 30 ohm]), anders zal het systeem met de aardpotentialaal verbonden zijn via de condensatoren van het EMC-filter van de omvormer. Dit kan gevaar opleveren of de omvormer beschadigen.

NL

Installeer de omvormer niet met aangesloten intern EMC-filter bij installatie in een hoekgeaard TN-systeem, anders zal de omvormer beschadigd worden.

Opmerking: Wanneer het interne EMC-filter ontkoppeld is, wordt de EMC-compatibiliteit aanzienlijk minder.

■ Aarde-naar-fase varistor

De aarde-naar-fase varistor is niet geschikt voor gebruik in een IT (ongeaard) systeem. Ontkoppel de aarde-naar-fase varistor voordat u de omvormer aansluit op het voedingsnetwerk. Controleer de tabel op pagina **88**.

⚠ WAARSCHUWING! Installeer de omvormer niet met de aarde-naar-fase varistor aangesloten op een IT-systeem (een ongeaard vermogenssysteem of een over een hoge weerstand geaard [meer dan 30 ohm] vermogenssysteem), anders kan het varistor-circuit beschadigd worden.

R6-
R9

Controleer in onderstaande tabel of u het EMC-filter (EMC) of de aarde-naar-fase varistor (VAR) los moet koppelen. Voor instructies over hoe u dit kunt doen, zie pagina 89.

Frame-afmeting	EMC-filter EMC	Aarde-naar-fase varistor VAR	Symmetrisch geaarde TN-systemen (TN-S systemen) ¹	Corner grounded TN systemen ²	IT-systemen (ongeaard of hoogohmig geaard [>30 ohms]) ³
R6...R9	EMC (2 schroeven)	-	Niet loskoppelen	Loskoppelen	Loskoppelen
	-	VAR (1 schroef)	Niet loskoppelen	Niet loskoppelen	Loskoppelen

1

Omvormer

2

Omvormer

3

Omvormer

■ Ontkoppel, indien nodig, het EMC-filter of de aarde-naar-fase varistor

Om het interne EMC-filter of de aarde-naar-fase varistor, indien nodig, te ontkoppelen, handelt u als volgt:

1. Schakel de voeding van de omvormer uit.
2. Open de frontkap, indien deze nog niet open is, zie de stappen 5, IP21 en 5, IP55 in figuur *R6...R9 Figures A* op pagina 157.
3. Om het interne EMC-filter te ontkoppelen, verwijdert u de twee EMC-schroeven.
4. Om de aarde-naar-fase varistor te ontkoppelen, verwijdert u de varistorschroef.

R6-
R9

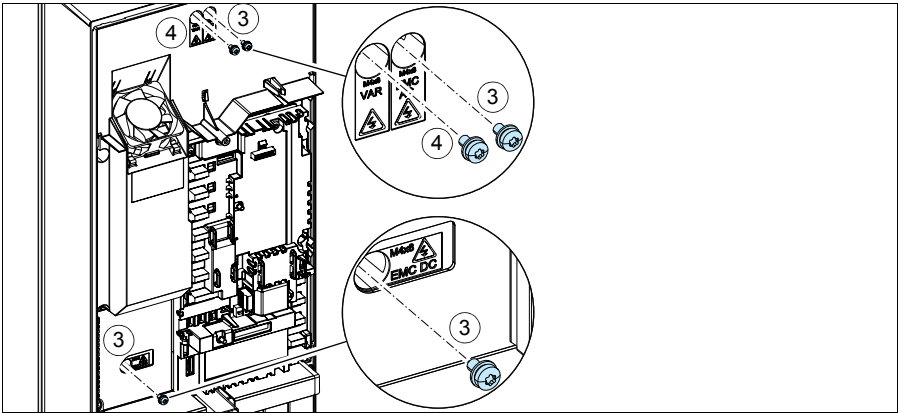

NL

Sluit de vermogenskabels aan

Zie figuur C op pagina 157. Gebruik symmetrisch afgeschermd kabel voor de motor-bekabeling. Als de kabelafscherming de enige PE-geleider voor de omvormer of motor is, zorg er dan voor dat deze voldoende geleidbaar is voor de PE.

1. Bevestig de waarschuwingssticker tegen restspanning in de plaatselijke taal vlak bij de stuurkaart.
2. Verwijder de zijplaten van het kabelangangsblok. Maak de bevestigingsschroeven los en schuif de platen eruit.
3. Verwijder de afdekking op de vermogenskabelklemmen door de clips los te maken met een schroevendraaier en de afdekking er uit te trekken.
4. Druk de gaten uit voor de te installeren kabels
5. Snijd een geschikt gat in de rubberen doorvoertule. Schuif de doorvoertule op de kabel.
6. Maak de uiteinden van de voedings- en motorkabels gereed zoals in de figuur geïllustreerd. **Opmerking:** De blote afscherming moet over 360 graden geaard worden. Markeer de pigtail die van de afscherming gemaakt is, als PE-geleider met een gele-en-groene kleur.
7. Schuif de kabels door de gaten in de bodemplaat en bevestig de doorvoertules in de gaten (de motorkabel rechts en de voedingskabel links).
8. Sluit de motorkabel aan:
 - Aard de kabelafschermingen over 360 graden onder de aardingsklem (8a).
 - Sluit de getwiste afscherming van de kabel aan op de aardklem (8b).
 - Sluit de fasegeleiders van de kabel aan op de T1/U, T2/V en T3/W klemmen. Draai de schroeven vast tot het aanhaalmoment gegeven in figuur (8c).
Opmerking: Fasegeleiders (R8, R9) zijn uitneembaar.
9. Sluit de voedingskabel aan zoals in stap 8. Gebruik aansluitklemmen L1, L2 en L3.
10. R8...R9: Als u parallelle kabels installeert, installeer dan de tweede aardingsplaat voor de parallelle vermogenskabels. Herhaal de stappen 5...9.
11. Installeer de aardingsplaat voor de besturingskabels.
12. Zet de afdekking op de vermogensklemmen terug.
13. Zet de kabels buiten de unit mechanisch vast.
14. Aard de motorkabelafscherming aan de motorzijde. Voor minimale radiofrequentie-interferentie, dient de motorkabelafscherming over 360 graden geaard te worden bij de doorvoer van de motorklemmenkast.

R6-
R9

NL

Sluit de besturingskabels aan

Zie figuur *D* op pagina 158. Deze toont een voorbeeld met één analoge signaalkabel en één digitale signaalkabel. Maak de aansluitingen volgens de standaard configuratie in gebruik. De standaard aansluitingen van de HVAC standaard configuratie zijn te zien in de sectie *Standaard I/O aansluitingen* op pagina 92.

Voorbeeld van aansluiten van een analoge signaalkabel:

1. Snij een voldoende groot gat in de rubberen doorvoertule en schuif de doorvoertule op de kabel. Schuif de kabel door een gat van de bodemplaat en maak de doorvoertule in het gat vast.
2. Aard de gestripte buitenste afscherming van de kabel over 360 graden onder de aardklem. Houd de kabel ongestript tot zo dicht mogelijk bij de aansluitklemmen van de besturingskaart. Aard bij analoge signaalkabels ook de afschermingen van het kabelpaar en de aardader bij de SCR1 klem. Zet de kabels mechanisch vast bij de klemmen onder de stuurkaart.
3. Leid de kabel zoals te zien in de figuur.
4. Sluit de geleiders aan op de betreffende klemmen van de stuurkaart en draai vast tot 0,5...0,6 N·m (0.4 lbf·ft).
5. Bind alle besturingskabels aan de aanwezige kabelhouders.
6. Plaats de ongebruikte rubber doorvoertules in de gaten in de doorvoerplaat.

**R6-
R9****NL**

Standaard I/O aansluitingen

Standaard I/O-aansluitingen van de HVAC standaard configuratie worden hieronder getoond.

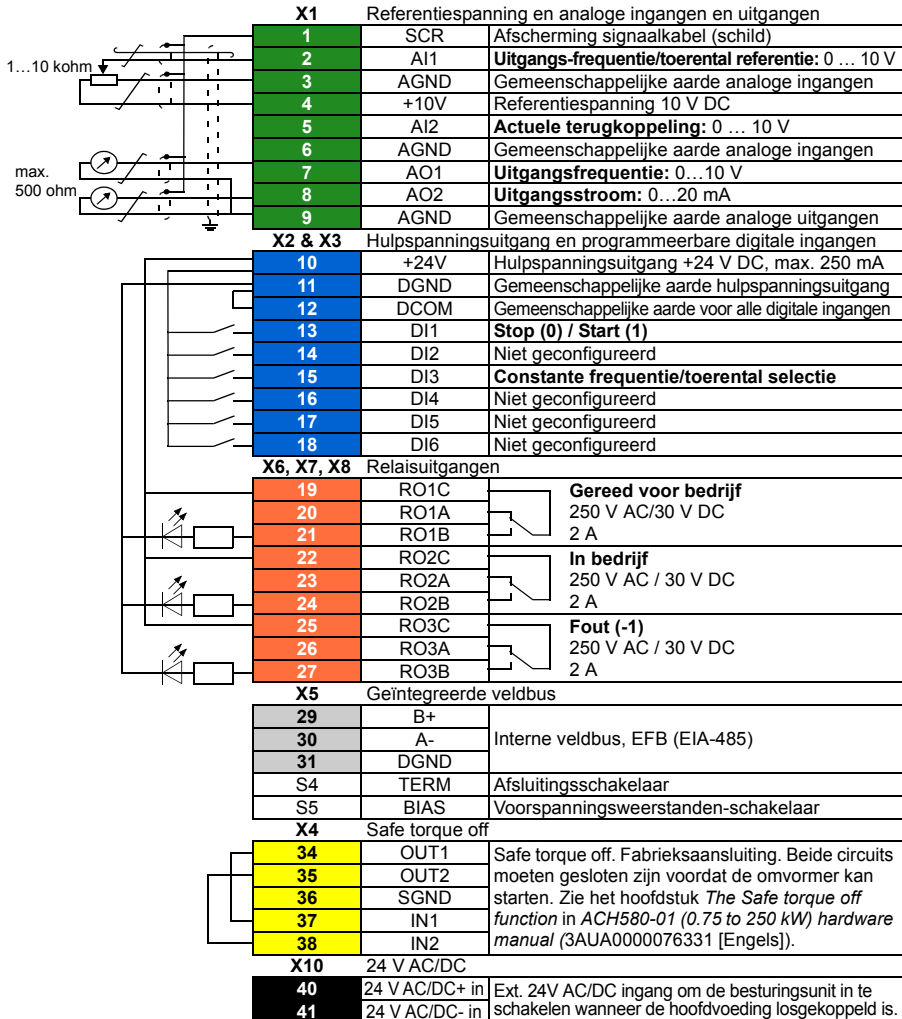
R6-
R9

NL

Totale belastingcapaciteit van de hulpspanningsuitgang +24V (X2:10) is 6,0 W (250 mA / 24 V DC).

Ader-afmetingen: 0,14 ... 2,5 mm² (26...16 AWG): Alle aansluitklemmen

Aanhaalmomenten: 0,5...0,6 N·m (0,4 lbf·ft)

Installeren van eventuele optionele modules

Zie het hoofdstuk *Electrical installation* in *ACH580-01 (0.75 to 250 kW) hardware manual* (3AUA0000076331 [Engels]).

Installeer zijplaten en kappen

Zie figuur [R6...R9 Figures E](#) op pagina [159](#).

**R6-
R9**

IP21

1. Zet de zijplaten van het kabelingangsblok terug. Draai de bevestigingsschroeven vast met een schroevendraaier.
2. Schuif de kap van het kabelingangsblok vanaf onder op de module totdat de kap op zijn plaats klikt.
3. Zet de modulekap terug. Draai de twee bevestigingsschroeven vast met een schroevendraaier.

IP55

1. Zet de modulekap terug. Draai de twee bevestigingsschroeven vast met een schroevendraaier.

Zie voor opstart-instructies het hoofdstuk [NL – Beknopte opstartgids](#) op pagina [205](#).

NL

R6-
R9

NL

PL – Skrócona instrukcja montażu – obudowy R6...R9

Ta instrukcja zawiera krótki opis sposobu montażu przemiennika częstotliwości. Pełne informacje dotyczące montażu zawiera dokument *ACH580-01 (0.75 to 250 kW) hardware manual* (3AUA0000076331 [j. ang.]). Instrukcje uruchamiania zawiera rozdział *PL – Skrócona instrukcja uruchamiania* na stronie 211.

Aby przeczytać podręcznik, przejdź na stronę www.abb.com/drives/documents i wyszukaj numer dokumentu.

R6-
R9

Należy przestrzegać instrukcji bezpieczeństwa



OSTRZEŻENIE! Należy przestrzegać tych instrukcji. Nieprzestrzeganie instrukcji może skutkować obrażeniami, śmiercią lub uszkodzeniem urządzenia:

- Wszelkie elektryczne prace instalacyjne powinny być wykonywane tylko przez wykwalifikowanych elektryków.
- Nie można wykonywać żadnych prac przy przemienniku częstotliwości, kablu silnika ani silniku, jeśli podłączone jest źródło zasilania. Jeśli przemiennik częstotliwości jest już podłączony do zasilania, należy odczekać 5 minut po jego odłączeniu.
- Nie można wykonywać żadnych prac przy kablach sterowania, jeśli do przemiennika częstotliwości lub zewnętrznych obwodów sterowania doprowadzone jest zasilanie.
- Przemiennik częstotliwości należy podnosić za przeznaczone do tego celu uchwyty. Nie przechylać przemiennika. Przemiennik jest ciężki i ma wysoko położony środek ciężkości. Przewracający się przemiennik może spowodować fizyczne obrażenia.
- Podczas montażu należy uważać, aby opiłki powstające w trakcie wiercenia i szlifowania nie przedostały się do wnętrza przemiennika częstotliwości.
- Należy upewnić się, że podłoga pod przemiennikiem częstotliwości i ściana, na której jest zainstalowany, nie są łatwopalne.

PL

Sprawdzenie, czy kondensatory wymagają formowania

Formowanie kondensatorów należy wykonać, jeśli przemiennik częstotliwości nie był włączany od ponad roku (był w magazynie lub nie był używany).

Datę produkcji można określić na podstawie numeru seryjnego, który jest widoczny na tabliczce znamionowej przymocowanej do przemiennika częstotliwości. Numer seryjny ma format MRRTTRXXXX. RR i TT określają rok i tydzień produkcji w następujący sposób:

RR: 13, 14, 15, ... oznacza 2013, 2014, 2015, ...

TT: 01, 02, 03, ... oznacza 1 tydzień, 2 tydzień, 3 tydzień, ...

Więcej informacji na temat formowania kondensatorów zawiera dokument *Converter module capacitor reforming instructions* (3BFE64059629 [j.ang.]), który jest dostępny na stronie internetowej www.abb.com/drives/documents.

R6-
R9

Dobór kabli zasilania

Kable zasilania należy zwymiarować zgodnie z obowiązującymi przepisami lokalnymi, tak aby zapewnić przepływ prądu znamionowego, którego wartość jest podana na tabliczce znamionowej przemiennika częstotliwości.

Zapewnianie chłodzenia

Informacje dotyczące rozpraszania ciepła zawiera tabela I na stronie 13 (UL: tabela II na stronie 13). Dozwolony zakres temperatury pracy przemiennika częstotliwości wynosi od -15 do +50°C (od +5 do +122°F). Nie jest dopuszczalne skraplanie i oszronienie. Więcej informacji o temperaturze otoczenia i obniżaniu wartości znamionowych zawiera rozdział *Technical data* w dokumencie *ACH580-01 (0.75 to 250 kW) hardware manual* (3AUA0000076331 [j. ang.]).

Ochrona przemiennika częstotliwości i kabla zasilania wejściowego

Informacje o bezpiecznikach można znaleźć w tabelach III, IV i V na str. 14 i 14.

Jeśli używane są bezpieczniki gG, należy upewnić się, że czas zadziałania bezpiecznika jest krótszy niż 0,5 sekundy. Należy przestrzegać lokalnych przepisów.

Montaż przemiennika częstotliwości na ścianie

PL



Ostrzeżenie Moduł przemiennika częstotliwości jest ciężki (42 do 103 kg / 93 do 227 lb). Należy użyć odpowiedniego podnośnika. Nie należy podnosić modułu ręcznie. Należy upewnić się, że ściana oraz mocowania są wystarczająco wytrzymałe, aby utrzymać ciężar modułu.

Patrz rysunek *R6...R9 Figures A* na stronie 157.

Sprawdzanie izolacji kabli zasilania i silnika

Przed podłączeniem kabla wejściowego do przemiennika częstotliwości należy sprawdzić, czy jego izolacja jest zgodna z lokalnymi przepisami.

Patrz rysunek **B** na stronie **157**.

1. Przed podłączeniem kabla silnika i silnika do przemiennika częstotliwości sprawdzić jego izolację. Zmierzyć rezystancję izolacji pomiędzy poszczególnymi przewodami fazowymi, a następnie pomiędzy każdym przewodem fazowym i przewodem uziomowym przy użyciu napięcia pomiarowego 1000 V DC. Rezystancja izolacji typowego silnika musi przekraczać 100 MΩ (wartość zadana przy temperaturze 25°C lub 77°F). Informacje o rezystancji izolacji silników zawierają instrukcje dostarczone przez producenta.

R6-R9

Uwaga: Wilgoć wewnątrz obudowy silnika zmniejsza rezystancję izolacji. W przypadku pojawienia się wilgoci należy wysuszyć silnik i powtórzyć pomiar.

Sprawdzanie zgodności z sieciami IT (bez uziemienia) i sieciami TN (z uziemieniem wierzchołkowym)

■ Filtr EMC

Wewnętrzny filtr EMC nie jest przystosowany do użycia z sieciami IT (bez uziemienia) i sieciami TN z uziemieniem wierzchołkowym. Odłączyć filtr EMC przed podłączeniem przemiennika częstotliwości do sieci zasilającej. Więcej informacji zawiera tabela na stronie **98**.



OSTRZEŻENIE! Nie instalować przemiennika częstotliwości z podłączonym wewnętrznym filtrem EMC w sieci IT (sieci zasilania bez uziemienia lub sieci zasilania uziemionej przez rezystancję o wysokiej wartości — ponad 30 Ω), ponieważ spowoduje to sytuację, w której sieć zostanie podłączona do potencjału uziemienia za pomocą kondensatorów filtra EMC znajdujących się w przemienniku. Może to spowodować zagrożenie lub uszkodzić przemiennik częstotliwości.

PL

Nie instalować przemiennika częstotliwości z podłączonym wewnętrznym filtrem EMC w sieci TN z uziemieniem wierzchołkowym, ponieważ spowoduje to uszkodzenie przemiennika częstotliwości.

Uwaga: Kiedy wewnętrzny filtr EMC jest odłączony, zgodność elektromagnetyczna przemiennika częstotliwości jest znacznie ograniczona.

■ Warystor uziemienie-faza

Warystor uziemienie-faza nie jest przystosowany do użycia z sieciami IT (bez uziemienia). Należy odłączyć warystor uziemienie-faza przed podłączeniem przemiennika częstotliwości do sieci zasilającej. Więcej informacji zawiera tabela na stronie **98**.

⚠ OSTRZEŻENIE! Nie należy montować przemiennika częstotliwości z warystorem uziemienie-faza podłączonym w sieci IT (sieci zasilania bez uziemienia lub sieci zasilania uziemionej przez rezystancję o wysokiej wartości — ponad 30 Ω), ponieważ może to uszkodzić obwód warystora.

R6-
R9

Aby dowiedzieć się, czy należy odłączyć filtr EMC (EMC) lub warystor uziemienie-faza (VAR), należy zapoznać się z poniższą tabelą. Instrukcje odłączania znajdują się na str. 99.

Rozmiary obudowy	Filtr EMC (EMC)	Warystor uziemienie-faza (VAR)	Symetrycznie uziemione systemy TN (systemy TN-S) ¹	Wierzchołkowo uziemione systemy TN ²	Systemy IT (bez uziemienia lub z uziemieniem przez rezystancję o wysokiej wartości — ponad 30 Ω) ³
R6...R9	EMC (2 wkręty)	-	Nie odłączać	Odłączyć	Odłączyć
	-	VAR (1 wkręt)	Nie odłączać	Nie odłączać	Odłączyć

1

Przemiennik częstotliwości

2

Przemiennik częstotliwości

3

Przemiennik częstotliwości

■ Odłączanie filtra EMC lub warystora uziemienie-faza, jeśli jest to wymagane

Aby odłączyć wewnętrzny filtr EMC lub warystor uziemienie-faza, gdy jest to wymagane, należy wykonać te czynności:

1. Odłączyć zasilanie od przemiennika częstotliwości
2. Otworzyć przednią osłonę, jeśli nie jest jeszcze otwarta. Patrz kroki 5, IP21 i 5, IP55 na rysunku *R6...R9 Figures A* na stronie 157.
3. Aby odłączyć wewnętrzny filtr EMC, odkręcić dwa wkręty EMC.
4. Aby odłączyć warystor uziemienie-faza, odkręcić wkręt warystora.

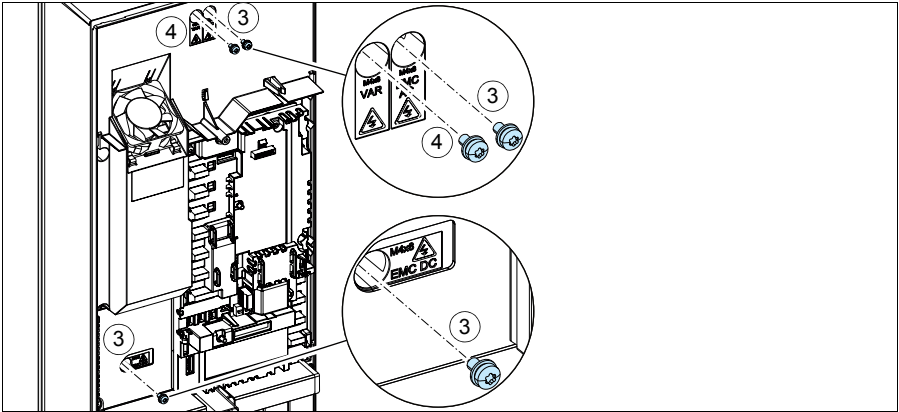
R6-
R9

PL

Podłączanie kabli zasilania

Patrz rysunek **C** na stronie **157**: W okablowaniu silnika należy używać symetrycznego kabla ekranowanego. Jeśli ekran kabla jest pojedynczym przewodem uziomowym dla przemiennika częstotliwości lub silnika, należy upewnić się, że ma odpowiednią przewodność dla przewodu uziomowego.

1. Przykleić naklejkę z ostrzeżeniem o napięciu szczytkowym w odpowiednim języku obok tablicy rozdzielczej.
2. Zdjąć płyty boczne skrzynki kablowej. Poluzować wkręty mocujące i wysunąć ściany.
3. Usunąć osłonę zacisków kabla zasilania, zwalniając zaczepy wkrętakiem i zdejmując osłonę.
4. Przygotować otwory dla kabli, które będą podłączane.
5. Wyciąć odpowiedni otwór w gumowym dławiku. Nasunąć dławik na kabel.
6. Przygotować końcówki kabli zasilania wejściowego oraz silnika w sposób przedstawiony na rysunku. **Uwaga:** Odsłonięty ekran będzie uziemiony na całym obwodzie. Oznaczyć końcówkę wykonaną z ekranu jako przewód uziomowy (PE) za pomocą kolorów żółtego i zielonego.
7. Przeciągnąć kable przez otwory w płycie dolnej i zamocować dławiki w tych otworach (kabel silnika po prawej stronie i kabel zasilania wejściowego po lewej).
8. Podłączyć kabel silnika.
 - Wykonać uziemienie ekranu kabla na całym obwodzie kabla pod zaciskiem uziomowym (8a).
 - Podłączyć skręcany ekran kabla do zacisku uziomowego (8b).
 - Podłączyć przewody fazowe kabla do zacisków T1/U, T2/V i T3/W. Dokręcić wkręty z momentem siły podanym na rysunku (8c). **Uwaga:** Przewody fazowe (R8, R9) można odłączyć.
9. Podłączyć kable zasilania wejściowego tak jak w kroku **8**. Użyć zacisków L1, L2 i L3.
10. **R8...R9:** W przypadku montażu równoległego zamontować drugą listwę uziemiającą dla równoległych kabli zasilania. Powtórzyć kroki **5...9**.
11. Zamontować listwę uziemiającą dla kabli sterowania.
12. Zamontować ponownie osłonę zacisków zasilania.
13. Zabezpieczyć kable mechanicznie na zewnątrz urządzenia.
14. Uziemić ekran kabla silnika po stronie silnika. Aby zminimalizować zakłócenia radiowe, uziemić ekran kabla silnika obwodowo (360 stopni) na przepuście skrzynki z zaciskami silnika.

R6-
R9

PL

Podłączanie kabli sterowania

Patrz rysunek *D* na stronie 158: Rysunek przedstawia przykład z jednym kablem sygnału analogowego i jednym kablem sygnału cyfrowego. Wykonać podłączenia zgodnie z używaną domyślną konfiguracją. Domyślne podłączenia domyślnej konfiguracji HVAC zawiera sekcja *Domyślne połączenia we/wy* na stronie 102

Przykład podłączania kabla sygnału analogowego:

1. Wyciąć odpowiedni otwór w gumowym dławiku i nasunąć go na kabel. Przeciągnąć kabel przez otwór w płycie dolnej i zamocować dławik w tym otworze.
2. Uziemić obwodowo (360 stopni) odsłonięty zewnętrzny ekran kabla pod zaciskiem uziemiającym. Osłonięta część kabla powinna znajdować się jak najbliżej zacisków karty sterowania. Dla kabli sygnału analogowego uziemić również ekrany kabli dwużyłowych i przewodu uziemiającego przy zacisku SCR1. Zabezpieczyć kable mechanicznie na zaciskach pod kartą sterowania.
3. Poprowadzić kabel, tak jak przedstawiono na rysunku.
4. Podłączyć przewody do odpowiednich zacisków karty sterowania i dokręcić zacisk z momentem 0,5...0,6 Nm (0,4 lbf ft).
5. Przywiązać wszystkie kable do mocowań kabli znajdujących się w zestawie.
6. Włożyć nieużywane gumowe dławiki do otworów w płycie przepustowej.

**R6-
R9****PL**

Domyślne połączenia we/wy

Poniżej znajdują się domyślne połączenia we/wy domyślnej konfiguracji HVAC .

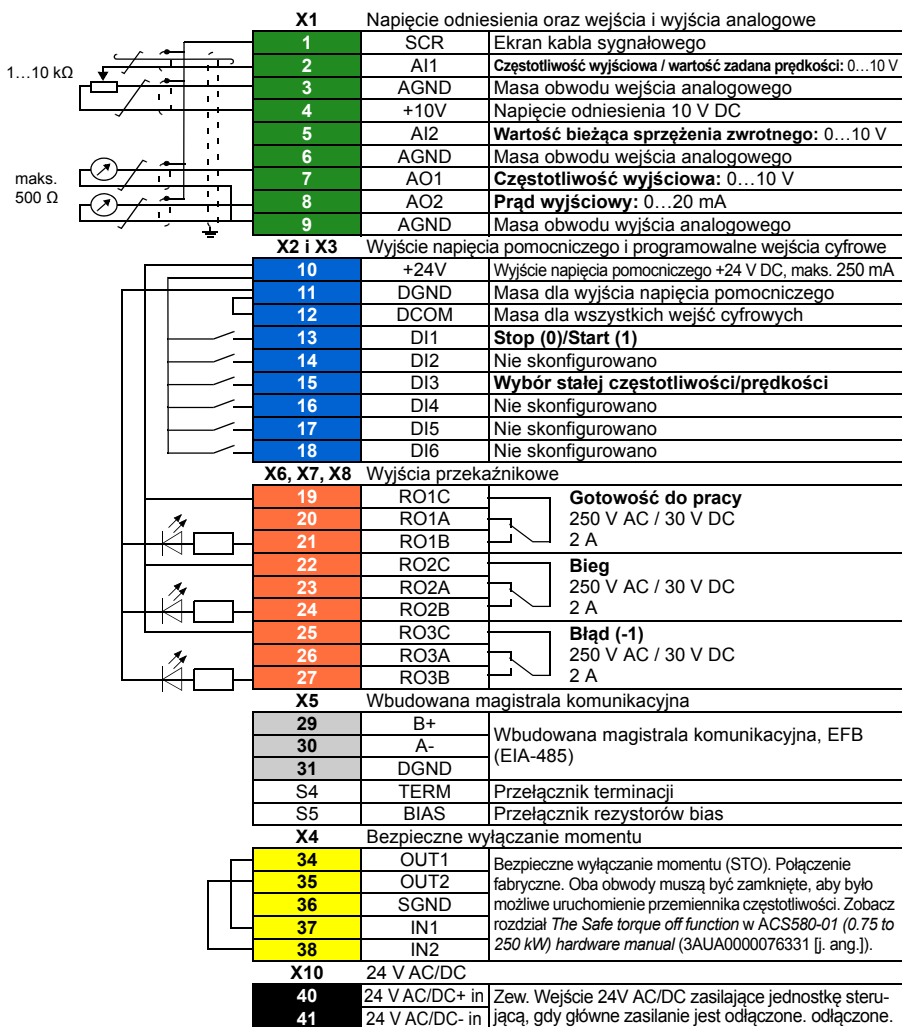
R6-
R9

PL

Całkowita obciążalność wyjścia napięcia pomocniczego +24 V (X2:10) wynosi 6,0 W (250 mA / 24 V DC).

Rozmiary przewodów: 0,14...2,5 mm² (26...16 AWG): Wszystkie zaciski

Momenty dokręcania: 0,5...0,6 N·m (0,4 lbf·ft)

Instalacja ewentualnych modułów opcjonalnych

Przeczytaj rozdział *Electrical installation* w dokumencie *ACH580-01 (0.75 to 250 kW) hardware manual* (3AUA0000076331 [j. ang.]).

Montowanie płyt bocznych i osłon

Patrz rysunek [R6...R9 Figures E](#) na stronie [159](#).

R6-
R9

IP21

1. Zamontować ponownie płyty boczne skrzynki kablowej. Dokręcić wkręt mocujący wkrętakiem.
2. Przesuwać osłonę skrzynki kablowej na module od dołu, aż osłona będzie na swoim miejscu.
3. Założyć ponownie osłonę modułu. Dokręcić dwa wkręty mocujące wkrętakiem.

IP55

1. Założyć ponownie osłonę modułu. Dokręcić dwa wkręty mocujące wkrętakiem.

Instrukcje uruchamiania zawiera rozdział [PL – Skrócona instrukcja uruchamiania](#) na stronie [211](#).

PL

R6-
R9

PL

PT – R6...R9 Guia de instalação rápida

Este guia descreve resumidamente como instalar o inversor de frequência. Para obter informações completas sobre a instalação, consulte o *ACH580-01 (0.75 to 250 kW) hardware manual* (3AUA0000076331 [inglês]). Para obter instruções de inicialização, consulte o capítulo *PT – Guia de início rápido* na página 217.

Para ler o manual, acesse www.abb.com/drives/documents e pesquise pelo número do documento.

R6-
R9

Obedeça às instruções de segurança



ADVERTÊNCIA! Obedeça a estas instruções. Ignorá-las pode causar danos físicos ou morte, ou danos ao equipamento:

- Se você não for um electricista qualificado, não realize serviços de instalação elétrica.
- Não opere o inversor de frequência, o cabo do motor ou o motor quando a energia principal estiver ligada. Se o inversor de frequência já estiver conectado à entrada de energia, aguarde 5 minutos após desconectá-lo.
- Não manipule os cabos de controle quando a alimentação de energia estiver aplicada no inversor de frequência ou nos circuitos de controle externo.
- Use os olhais de suspensão do inversor de frequência ao levantá-lo. Não incline o inversor de frequência. Ele é pesado e seu centro de gravidade é alto. O tombamento do inversor de frequência pode causar ferimentos físicos.
- Certifique-se de que detritos de perfurações e articulações não entrem no inversor de frequência durante a instalação.
- Certifique-se de que o chão abaixo do inversor de frequência e a parede na qual o inversor de frequência será instalado não sejam inflamáveis.

PT

Verifique se os capacitores precisam ser reformados

Se o inversor de frequência não tiver sido energizado (nunca tiver sido utilizado ou estiver armazenado) há mais de um ano, será necessário reformar os capacitores.

É possível determinar a data de fabricação com base no número de série, que pode ser encontrado na etiqueta de descrição do código, anexada ao inversor de frequência. O formato do número de série é MYYWWRXXXX. YY e WW se referem respectivamente ao ano e semana, conforme segue:

YY: 13, 14, 15, ... para 2013, 2014, 2015, ...

WW: 01, 02, 03, ... para semana 1, semana 2, semana 3, ...

Para obter informações sobre como reformar capacitores, consulte *Converter module capacitor reforming instructions*(3BFE64059629 [inglês]), disponível na internet em www.abb.com/drives/documents.

Selecione os cabos de força

Defina o tamanho dos cabos de força de acordo com os regulamentos locais, de modo que eles conduzam a corrente nominal fornecida na etiqueta de designação de tipo contida no inversor de frequência.

R6-
R9

Assegure que haja resfriamento

Consulte a tabela I na página 13 (UL: tabela II na página 13) para obter informações sobre dissipação de calor. A faixa de temperatura operacional permitida do inversor de frequência é de -15 a +50 °C (+5 a +122 °F). Não é permitida a condensação ou congelamento. Para obter mais informações sobre a temperatura ambiente e perda de potência, consulte o capítulo *Technical data* no *ACH580-01 (0.75 to 250 kW) hardware manual* (3AUA0000076331 [inglês]).

Proteja o inversor de frequência e o cabo de força de entrada

Consulte as tabelas III, IV e V nas páginas 14 e 14 para obter informações sobre fusíveis.

Se você utiliza fusíveis gG, o tempo de operação do fusível deve estar abaixo de 0,5 segundos. Siga os regulamentos locais.

Instale o inversor de frequência na parede



Advertência! O módulo do inversor de frequência é pesado (42 a 103 kg/93 a 227 lb). Use um dispositivo de levantamento adequado. Não levante o módulo manualmente. Certifique-se de que a parede e os dispositivos de fixação podem suportar o peso.

PT

Consulte a figura *R6...R9 Figures A* na página 157.

Verifique o isolamento dos cabos de energia e do motor

Verifique o isolamento do cabo de entrada de acordo com as normas locais antes de conectá-lo ao inversor de frequência.

Consulte a figura **B** na página **157**.

1. Verifique o isolamento do cabo do motor e do motor antes de conectá-lo no inversor de frequência. Meça a resistência do isolamento entre cada condutor de fase e, em seguida, entre cada condutor de fase e o condutor de proteção (PE) usando um medidor de tensão de 1.000 V CC. A resistência do isolamento de um motor típico deve exceder 100 Mohm (valor de referência em 25 °C ou 77 °F). Quanto à resistência do isolamento de motores, consulte as instruções do fabricante.

R6-
R9

Observação: Umidade dentro da caixa do motor reduzirá a resistência de isolamento. Se houver suspeita de umidade, seque o motor e repita a medição.

Verifique se há compatibilidade com os sistemas de IT (sem aterramento) e TN com aterramento no vértice

■ Filtro EMC

O filtro EMC interno não é adequado para uso em um sistema IT (sem aterramento) ou em um sistema TN com aterramento no vértice. Desconecte o filtro EMC antes de conectar o inversor de frequência à rede de alimentação. Consulte a tabela na página **108**.



ADVERTÊNCIA! Não instale o inversor de frequência com o filtro EMC interno conectado a um sistema IT (um sistema de energia sem aterramento ou um sistema de energia com aterramento de alta resistência [acima de 30 ohms]). Caso contrário, o sistema será ligado ao potencial de terra pelos capacitores de filtro EMC do inversor de frequência. Isso pode causar riscos ou até danificar o inversor de frequência.

Não instale o inversor de frequência com o filtro EMC interno conectado a um sistema TN com aterramento no vértice. Caso contrário, o inversor de frequência será danificado.

PT

Observação: Quando o filtro EMC interno for desconectado, a compatibilidade EMC do inversor de frequência será consideravelmente reduzida.

■ Varistor terra-fase

O varistor terra-fase não é adequado para uso em um sistema IT (sem aterramento). Desconecte o varistor terra-fase antes de conectar o inversor de frequência à rede de alimentação. Consulte a tabela na página **108**.

⚠️ ADVERTÊNCIA! Não instale o inversor de frequência com varistor terra-fase conectado a um sistema IT (um sistema de energia sem aterramento ou um sistema de energia com aterramento de alta resistência [acima de 30 ohms]). Caso contrário, o circuito do varistor pode ser danificado.

R6-R9

Verifique, usando a tabela abaixo, se é necessário desconectar o filtro EMC (EMC) ou o varistor terra-fase (VAR). Para obter instruções sobre como realizar esse procedimento, consulte a página [109](#).

Tamanhos de carcaça	Filtro EMC (EMC)	Varistor terra-fase (VAR)	Sistemas TN com aterramento simétrico (sistemas TN-S) ¹	Sistemas TN com aterramento de uma fase ²	Sistemas IT (sem aterramento ou com aterramento de alta resistência [>30 ohms]) ³
R6...R9	EMC (2 parafusos)	-	Não desconectar	Desconectar	Desconectar
	-	VAR (1 parafuso)	Não desconectar	Não desconectar	Desconectar

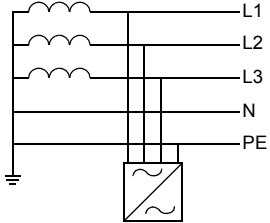
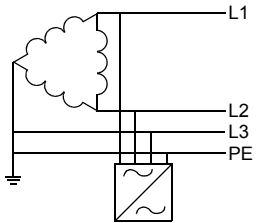
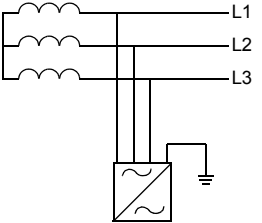
1	2	3
 <p>Inversor de frequência</p>	 <p>Inversor de frequência</p>	 <p>Inversor de frequência</p>

■ Desconecte o filtro EMC ou varistor terra-fase, se necessário

Para desconectar o filtro EMC interno ou varistor terra-fase, se necessário, siga as instruções abaixo:

1. Desligue a energia do inversor de frequência.
2. Abra a tampa frontal, caso ela ainda não esteja aberta. Consulte as etapas 5, IP21 e 5, IP55 na figura *R6...R9 Figures A* na página 157.
3. Para desconectar o filtro EMC interno, remova os dois parafusos do EMC.
4. Para desconectar o varistor terra-fase, remova o parafuso do varistor.

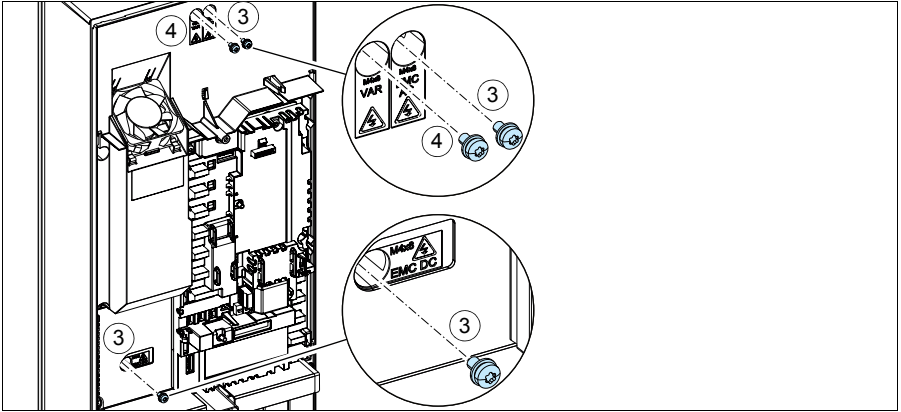
R6-
R9

PT

Conecte os cabos de força

Consulte a figura C na página 157. Use o cabo simétrico blindado para fazer o cabeamento do motor. Se a blindagem do cabo for o único condutor de PE para o inversor de frequência ou motor, certifique-se de que ela tenha condutividade o suficiente para a PE.

R6-
R9

1. Coloque o adesivo de advertência de tensão residual no idioma local ao lado da placa de controle.
2. Remova as placas laterais da caixa de entrada do cabo: Solte os parafusos de fixação e retire as paredes.
3. Remova a capa dos terminais do cabo de energia, retirando as travas com uma chave de fenda e retirando a capa.
4. Crie orifícios para que os cabos sejam instalados.
5. Faça um orifício adequado no anel isolante. Passe o anel pelo cabo.
6. Prepare as extremidades do cabo de energia de entrada e cabo do motor, como ilustrado na figura. **Observação:** A blindagem exposta será aterrada em 360 graus. Identifique o rabicho feito da blindagem como um condutor de PE utilizando as cores amarelo e verde.
7. Passe o cabo pelos orifícios da placa inferior e insira o anel no orifício (o cabo do motor à direita e o cabo de energia de entrada à esquerda).
8. Conecte o cabo do motor:
 - Faça o aterramento da blindagem em 360 graus, abaixo do grampo de aterramento (8a).
 - Conecte a blindagem torcida do cabo no terminal de aterramento (8b).
 - Conecte os condutores de fase do cabo nos terminais T1/U, T2/V e T3/W. Aperte os parafusos de acordo com o torque mostrado na figura (8c). **Observação:** Os condutores de fase (R8, R9) são destacáveis.

PT

9. Conecte o cabo de entrada de energia como mostrado na etapa 8. Use os terminais L1, L2 e L3.
10. R8...R9: Se você instalar paralelamente, instale a segunda prateleira de aterramento para os cabos de energia paralelos. Repita as etapas 5...9.
11. Instale a prateleira de aterramento dos cabos de controle.
12. Reinstale a capa nos terminais de energia.
13. Fixe mecanicamente os cabos fora do inversor de frequência.
14. Aterre a blindagem do cabo do motor na extremidade do motor. Para minimizar a interferência de radiofrequência, aterre a blindagem do cabo do motor em 360 graus na passagem da caixa terminal do motor.

Conecte os cabos de controle

Consulte a figura *D* na página 158. Ela mostra um exemplo com um cabo de sinal analógico e um cabo de sinal digital. Faça as conexões de acordo com a configuração padrão em uso. É possível encontrar informações sobre as conexões padrão da configuração padrão HVAC na seção *Conexões padrão de E/S* na página 112.

Exemplo de como conectar um cabo de sinal analógico:

1. Faça um orifício adequado no anel isolante e deslize o anel no cabo. Passe o cabo por um orifício da placa inferior e insira o anel no orifício.
2. Faça o aterramento da blindagem externa desencapada do cabo em 360 graus, abaixo do grampo de aterramento. Mantenha o cabo desencapado o mais próximo possível dos terminais da placa de controle. Para cabos de sinais analógicos, faça também o aterramento das blindagens de cabo par e fio terra no terminal SCR1. Fixe os cabos mecanicamente nos grampos abaixo da placa de controle.
3. Faça o roteamento dos cabos conforme mostra a figura.
4. Conecte os condutores aos terminais adequados da placa de controle e aperte com 0,5...0,6 N·m (0,4 lbf·ft).
5. Amarre todos os cabos de controle no suporte de cabos fornecido.
6. Coloque os anéis isolantes não usados nos orifícios da placa de passagem.

**R6-
R9****PT**

Conexões padrão de E/S

Abaixo, encontram-se informações sobre as conexões padrão de E/S da configuração padrão HVAC.

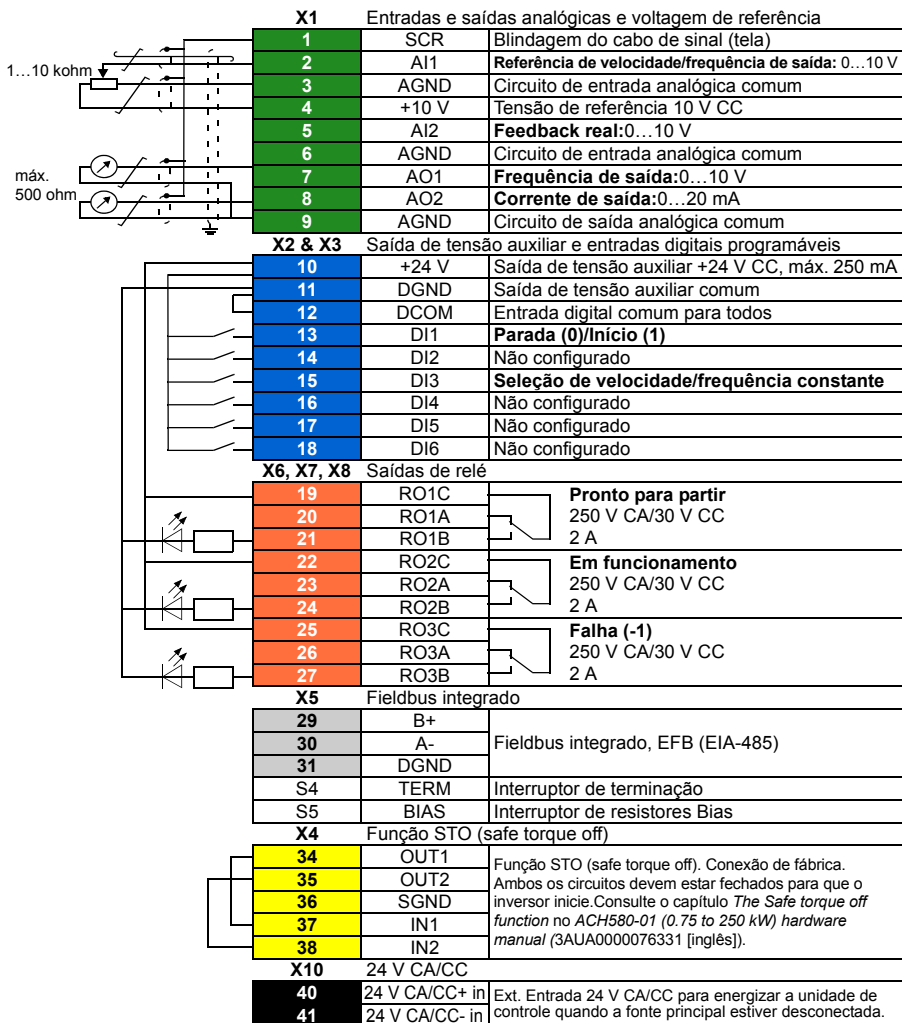
R6-
R9

PT

A capacidade total de carga da saída de tensão auxiliar + 24 V (X2:10) é 6,0 W (250 mA/24 V CC).

Tamanhos de cabo: 0,14...2,5 mm² (26...16 AWG): Todos os terminais

Torques de aperto: 0,5...0,6 N·m (0,4 lbf·ft)

Instale módulos opcionais, caso haja algum

Consulte o capítulo *Electrical installation* no *ACH580-01 (0.75 to 250 kW) hardware manual* (3AUA0000076331 [inglês]).

Instale as placas laterais e tampas

Consulte a figura [R6...R9 Figures E](#) na página [159](#).

**R6-
R9**

IP21

1. Reinstale as placas laterais da caixa de entrada do cabo. Aperte os parafusos de fixação com uma chave de fenda.
2. Deslize, de baixo para cima, a tampa da caixa de entrada do cabo no módulo até que ela fique encaixada.
3. Reinstale a tampa do módulo. Aperte os dois parafusos de fixação com uma chave de fenda.

IP55

1. Reinstale a tampa do módulo. Aperte os dois parafusos de fixação com uma chave de fenda.

Para obter instruções de inicialização, consulte o capítulo [PT – Guia de início rápido](#) na página [217](#).

PT

R6-
R9

PT

RU – Руководство по быстрому монтажу R6...R9

Настоящее руководство содержит краткое описание монтажа привода. Полное описание процесса монтажа приведено в документе *ACH580-01 (0.75 to 250 kW) hardware manual* (код английской версии 3AUA0000076331). Указания по вводу в эксплуатацию приведены в главе *RU – Краткое руководство по вводу в эксплуатацию* на стр. 223.

R6-
R9

Чтобы загрузить руководство, перейдите на страницу www.abb.com/drives/documents и найдите документ с этим кодом.

Следуйте указаниям по технике безопасности



ПРЕДУПРЕЖДЕНИЕ! Неукоснительно следуйте данным указаниям.

Отказ от следования данным указаниям может повлечь за собой получение травм, смерть или повреждение оборудования.

- Не следует выполнять электромонтажные работы, если вы не являетесь квалифицированным электриком.
- Запрещается выполнять какие-либо работы на приводе, двигателе или кабеле двигателя при включенном напряжении питания. Если на привод подано напряжение питания, то следует отключить напряжение питания, после чего подождать не менее 5 мин.
- Запрещается выполнять какие-либо работы с кабелями управления при наличии питания привода или внешних цепей управления.
- Поднимайте привод за имеющиеся монтажные проушины. Не наклоняйте привод. Привод имеет большой вес, и его центр тяжести расположен высоко. Опрокидывание привода может привести к травме.
- Перед тем как приступить к монтажу, следует исключить возможность попадания стружки, мусора и иных посторонних материалов внутрь привода.
- Убедитесь, что пол под приводом и стена, на которой установлен привод, выполнены из негорючего материала.

RU

Проверьте, не требуется ли формовка конденсаторов

Если на привод не подавалось питание (он находился на хранении или не использовался) более одного года, выполните формовку конденсаторов.

Дату изготовления можно определить по серийному номеру, который указан на табличке с обозначением типа, прикрепленной к приводу. Серийный номер имеет формат МYYWWRXXXX. YY и WW указывают год и неделю изготовления, а именно:

YY: 13, 14, 15, ... для 2013, 2014, 2015, ...

WW: 01, 02, 03, ... для 1-й недели, 2-й недели, 3-й недели, ...

Сведения о формовке конденсаторов см. в инструкции *Converter module capacitor reforming instructions* (код английской версии 3BFE64059629), которую можно скачать на странице www.abb.com/drives/documents.

R6-
R9

Выберите силовые кабели

Сечение силовых кабелей следует выбирать в соответствии с местными нормами и величиной номинального тока привода, указанной на его паспортной табличке.

Обеспечьте надлежащее охлаждение

Сведения о тепловыделении см. в таблице I на стр. 13 (UL: таблица II на стр. 13). Допустимый диапазон рабочих температур привода составляет от -15 до +50 °C. Образование конденсата или инея не допускается. Подробные сведения о температуре окружающей среды и снижении характеристик приведены в главе *Technical data* (Технические характеристики) документа *ACH580-01 (0.75 to 250 kW) hardware manual* (код английской версии 3AUA0000076331).

Защитите привод и входной силовой кабель от повреждений

Сведения о предохранителях см. в таблицах III, IV и V на стр. 14 и 14.

Если используются предохранители gG, убедитесь, что время срабатывания предохранителя меньше 0,5 секунды. Соблюдайте местные нормы и правила.

Закрепите привод на стене



Предупреждение! Приводной модуль имеет большую массу (42– 103 кг/ 93– 227 фунтов). Используйте подходящее подъемное устройство. Не поднимайте модуль вручную. Убедитесь, что стена и фиксаторы могут выдержать необходимый вес.

RU

См. рис. *R6...R9 Figures A* на стр. 157.

Проверьте сопротивление изоляции питающих кабелей и двигателя

Перед подключением сетевого кабеля к приводу проверьте его изоляцию в соответствии с требованиями местных норм и правил.

См. рис. *B* на стр. 157.

1. Перед подключением привода проверьте изоляцию кабеля двигателя и самого двигателя. Измерьте сопротивление изоляции между фазными проводниками, а затем между каждым фазным проводником и проводником защитного заземления, используя контрольное напряжение 1000 В=. Сопротивление изоляции типового двигателя должно превышать 100 МОм (эталонное значение при 25 °С). Сведения о сопротивлении изоляции двигателей см. в инструкциях изготовителей.

Примечание. Наличие влаги внутри корпуса двигателя приводит к снижению сопротивления изоляции. Если имеется подозрение о наличии влаги, просушите двигатель и повторите измерение.

Проверьте совместимость с системами IT (незаземленные сети) и системами TN с заземленной вершиной треугольника

■ ЭМС-фильтр

Внутренний ЭМС-фильтр не подходит для использования в системах питания IT (незаземленных) и TN (с заземленной вершиной треугольника). Отключите ЭМС-фильтр перед подключением привода к питающей сети. См. таблицу на стр. 118.



ПРЕДУПРЕЖДЕНИЕ! Не допускается подключение привода с внутренним ЭМС-фильтром к системе IT (незаземленная система или система электропитания с высокоомным [более 30 Ом] заземлением). В противном случае система оказывается соединенной с потенциалом земли через конденсаторы ЭМС-фильтра привода. Такая ситуация представляет угрозу безопасности и может привести к повреждению привода.

Не допускается подключение привода с внутренним фильтром ЭМС к системе TN с заземленной вершиной треугольника, поскольку это приведет к повреждению привода.

Примечание. Если внутренний ЭМС-фильтр отключен, электромагнитная совместимость привода существенно снижается.

■ Варистор «земля-фаза»

В системе IT (незаземленная сеть) не допускается применение варистора «земля-фаза». Отключите варистор «земля-фаза» перед подключением привода к питающей сети. См. таблицы на стр. 118.

R6-
R9

ПРЕДУПРЕЖДЕНИЕ! Не подключайте привод с варистором «земля-фаза» к системе IT (незаземленной системе или системе электроснабжения с высокоомным [более 30 Ом] заземлением), в противном случае возможно повреждение цепи варистора.

Проверьте по таблице ниже, следует ли отключить ЭМС-фильтр (EMC) или варистор «земля-фаза» (VAR). Инструкции по данной операции см. на стр. 119.

Типо-размеры	ЭМС-фильтр (ЭМС)	Варистор «земля-фаза» (VAR)	Симметрично заземленные системы TN (системы TN-S) ¹	Системы TN с заземленной вершиной треугольника ²	Системы IT (незаземленные или с высокоомным заземлением [$>30 \text{ Ом}$]) ³
R6...R9	ЭМС (2 винта)	-	Не отсоединяйте	Отсоедините	Отсоедините
	-	VAR (1 винт)	Не отсоединяйте	Не отсоединяйте	Отсоедините

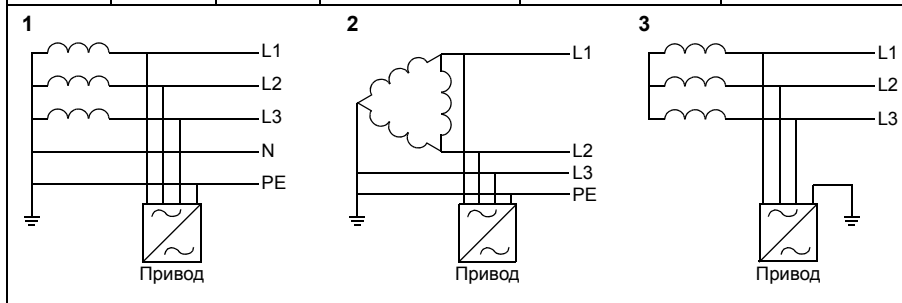

RU

■ При необходимости отключите ЭМС-фильтр или варистор «земля-фаза»

Для отключения внутреннего ЭМС-фильтра или варистора «земля-фаза» выполните следующие действия:

1. Отключите питание привода.
2. Откройте переднюю крышку, если она еще не открыта, см. шаги 5, IP21 и 5, IP55 на рис. [R6...R9 Figures A](#) на стр. 157.
3. Для отсоединения внутреннего ЭМС-фильтра удалите два ЭМС-винта.
4. Для отсоединения варистора «земля-фаза» удалите винт варистора.

R6-
R9

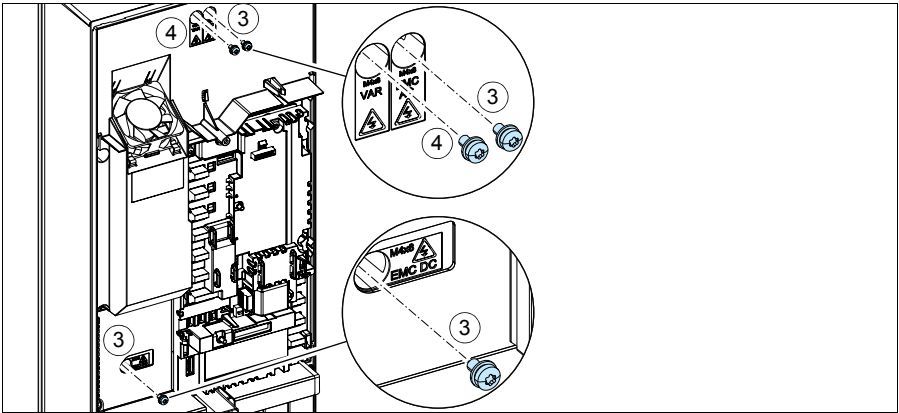

RU

Подключите силовые кабели

См. рис. C на стр. 157. Для подключения двигателя используйте симметричный экранированный кабель. Если экран кабеля является единственным проводником защитного заземления (PE) привода или двигателя, убедитесь, что проводимость экрана достаточна для защитного заземления.

R6-
R9

1. Прикрепите на плату управления наклейку с предупреждением об остаточных напряжениях (на местном языке).
 2. Снимите боковые панели коробки ввода кабелей: ослабьте удерживающие винты и выдвиньте боковые стенки.
 3. Удалите щиток с клемм силовых кабелей, для чего освободите зажимы при помощи отвертки и вытяните щиток наружу.
 4. Выберите отверстия для прохода кабелей.
 5. Прорежьте в резиновой манжете отверстие требуемого размера. Пропустите кабель через манжету.
 6. Подготовьте концы входного силового кабеля и кабеля двигателя, как показано на рисунке. **Примечание.** Обнаженный экран заземляется по окружности (360 градусов). Пометьте косичку из экрана как PE-проводник зеленым и желтым цветом.
 7. Пропустите кабели через отверстия в нижней панели и закрепите манжеты в отверстиях (кабель двигателя — в правое, а входной силовой кабель — в левое).
 8. Подключите кабель двигателя:
 - Заземлите экраны кабелей по окружности (360 градусов) под зажимом заземления (8a).
 - Подключите скрученный экран кабеля к клемме заземления (8b).
 - Подключите фазные проводники кабеля к клеммам T1/U, T2/V и T3/W. Затяните винты с моментом, указанным на рисунке (8c). **Примечание.** Фазные провода (R8, R9) являются съемными.
 9. Подключите входной силовой кабель так же, как на шаге 8. Используйте клеммы L1, L2 и L3.
- RU**
10. R8...R9: При монтаже параллельных кабелей установите вторую полку заземления для параллельных силовых кабелей. Повторите шаги 5...9.
 11. Установите зажим заземления для кабелей управления.
 12. Возвратите щиток на клеммы питания.
 13. Механически закрепите кабели за пределами модуля привода.
 14. Заземлите экран кабеля двигателя со стороны двигателя. Для сведения к минимуму радиочастотных помех обеспечьте заземление экрана кабеля двигателя по всей окружности (360 градусов) на входе в клеммную коробку двигателя.

Подключите кабели управления

См. рис. *D* на стр. 158. На нем показан пример подключения одного кабеля аналоговых и одного кабеля цифровых сигналов. Выполните подключение в соответствии с используемой конфигурацией по умолчанию. Соединения, используемые в конфигурации HVAC по умолчанию показаны в разделе *Стандартные подключения входов/выходов* на стр. 122.

Пример подключения кабеля аналоговых сигналов:

1. Прорежьте отверстие требуемого размера в резиновой манжете и наденьте манжету на кабель. Пропустите кабель сквозь отверстия в нижней панели и закрепите манжету в отверстии.
2. Заземлите зачищенный внешний экран кабеля по окружности (360 градусов) зажимом заземления. Незачищенная часть кабеля должна как можно ближе подходить к клеммам платы управления. В случае кабелей аналоговых сигналов заземлите также экраны кабелей «витая пара» и провод заземления, присоединив их к клемме SCR1. Закрепите кабели зажимами под платой управления.
3. Проложите кабель, как показано на рисунке.
4. Подключите проводники к соответствующим клеммам платы управления и затяните моментом 0,5...0,6 Н·м.
5. Притяните все кабели управления к предусмотренным для этого креплениям кабельных стяжек.
6. Установите неиспользованные резиновые манжеты в отверстия в проходной панели.

R6-
R9

RU

Стандартные подключения входов/выходов

Ниже показано подключение входов/выходов, используемое в конфигурации HVAC по умолчанию.

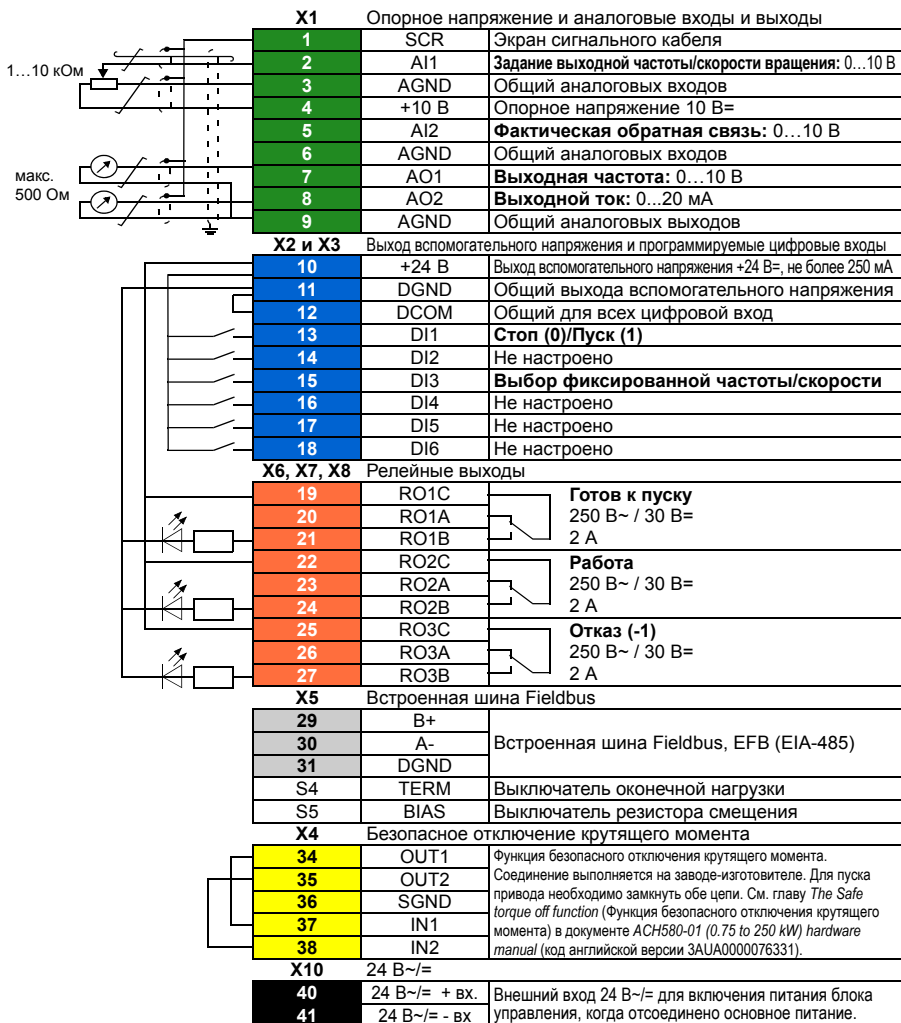
R6-
R9

RU

Общая нагрузочная способность выхода вспомогательного напряжения +24 В (X2:10) составляет 6,0 Вт (250 мА / 24 В=).

Сечение проводов: 0,14...2,5 мм²: все клеммы

Моменты затяжки: 0,5...0,6 Н·м

Установите дополнительные модули, если таковые имеются

См. главу *Electrical installation* (Электрический монтаж) в документе *ACH580-01 (0.75 to 250 kW) hardware manual* (код английской версии 3AUA0000076331).

Установите боковые панели и крышки

R6-
R9

См. рис. *R6...R9 Figures E* на стр. 159.

IP21

1. Установите на место боковые панели коробки ввода кабелей. Затяните удерживающие винты при помощи отвертки.
2. Вставьте крышку коробки ввода кабелей в модуль снизу и протолкните до щелчка.
3. Установите на место крышку модуля. Затяните два удерживающих винта при помощи отвертки.

IP55

1. Установите на место крышку модуля. Затяните два удерживающих винта при помощи отвертки.

Указания по вводу в эксплуатацию см. в главе *RU – Краткое руководство по вводу в эксплуатацию* на стр. 223.

RU

R6-
R9

RU

SV – R6...R9 Snabbguide för installation

Denna guide beskriver i korthet hur frekvensomriktaren installeras. För fullständig information om installationen, se *ACH580-01 (0.75 to 250 kW) hardware manual* (3AUA0000076331 [engelska]). Idrifftagningsinstruktioner finns i kapitel *SV – Snabbguide för idrifttagning* på sidan 229.

R6-
R9

Handledningarna finns att läsa på www.abb.com/drives/documents. Sök efter dokumentnumret.

Följ säkerhetsinstruktionerna



WARNING! Följ dessa instruktioner. Om instruktionerna inte följs kan det orsaka personskador eller dödsfall eller skador på utrustningen:

- Elektriskt installationsarbete får endast utföras av utbildad elektriker.
 - Arbeta inte med frekvensomriktaren, motorkabeln eller motorn när nätspänning är påslagen. Om frekvensomriktaren är ansluten till matningsspänning, vänta 5 minuter efter att den har frånskilts.
 - Arbeta aldrig med styrkablarna om frekvensomriktaren eller dess externa styrkretsar är spänningssatta.
 - Håll i frekvensomriktarens lyftöglor när den ska lyftas. Luta inte frekvensomriktaren. Frekvensomriktaren är tung och har hög tyngdpunkt. Om en frekvensomriktare välter kan det uppstå personskador.
 - Var noga med att inga borrh- eller slipspån kommer in i frekvensomriktaren i samband med installationen.
 - Var noga med att golvet under frekvensomriktaren och väggen där frekvensomriktaren är installerad är av icke brännbart material.
-

Kontrollera om kondensatorerna måste reformeras

Om frekvensomriktaren inte har varit i drift (antingen i förvaring eller inte använts) på över ett år måste kondensatorerna omformateras.

SV

Tillverkningsdatumet kan fastställas med serienumren som finns på typbeteckningsetiketten på frekvensomriktaren. Serienumret är i formatet MÅÅVVVRXXXX. ÅÅ och VV visar tillverkningsår och -vecka enligt följande:

ÅÅ: 13, 14, 15, ... för 2013, 2014, 2015, ...

VV: 01, 02, 03, ... för vecka 1, vecka 2, vecka 3, ...

För information om kondensatorformatering, se *Converter module capacitor reforming instructions* (3BFE64059629 [engelska]), på Internet på www.abb.com/drives/documents.

Anslutning av kraftkablar

Dimensionera kraftkablarna enligt lokala föreskrifter och den märkström som anges på frekvensomriktarens typbeteckningsetikett.

R6-
R9

Kontrollera att kylingen är tillfredsställande

Se tabell I på sidan 13 (UL: tabell II på sidan 13) för värmegenerering. Tillåtet driftstemperaturområde för frekvensomriktaren utan nedstämpling är -15 till +50 °C. Ingen kondens eller frost tillåts. För mer information om omgivningstemperatur och nedstämpling, se kapitel *Technical data* i *ACH580-01 (0.75 to 250 kW) hardware manual* (3AUA0000076331 [engelska]).

Skydda frekvensomriktaren och matningskabeln

Se tabellerna III, IV och V på sidorna 14 och 14 för säkringar.

Om du använder gG-säkringar, se till att utlösningstiden för säkringen understiger 0,5 sekunder. Följ lokala föreskrifter.

Installera frekvensomriktaren på vägg

 **Warning!** Frekvensomriktarmodulen är tung (42 till 103 kg / 93 till 227 lb). Använd en lämplig lyftenhet. Lyft inte modulen manuellt. Kontrollera att väggen och fästånordningarna kan bära vikten.

Se figur R6...R9 Figures A på sidan 157.

Kontrollera isolationen hos matningskablarna och motorn

Kontrollera nätkabelns isolation enligt lokala föreskrifter innan den ansluts till frekvensomriktaren.

Se figur *B* på sidan *157*.

1. Kontrollera motorkabelns och motorns isolation innan de ansluts till frekvensomriktaren. Mät isolationsresistansen mellan fasledarna och mellan varje fas och skyddsjordledare med en mätspänning på 1000 V DC. Isolationsresistansen hos en typisk motor måste överskrida 100 Mohm (referensvärde vid 25 °C). För isolationsresistans hos motorer, se respektive tillverkares instruktioner.

R6-
R9

Obs! Fukt inuti motorkapslingen minskar isolationsresistansen. Om fukt misstänks, torka motorn och upprepa mätningen.

Kontrollera kompatibilitet med IT-system (icke-direktjordade) och impedansjordade TN-system

■ EMC-filter

Det interna EMC-filtret är inte lämpligt för användning i ett IT-system (ojordat) eller i ett hörnjordat TN-system. Koppla bort EMC-filtret före anslutning av frekvensomriktaren till matningsnätet. Se tabellen på sidan *128*.



WARNING! Installera inte frekvensomriktaren med det interna EMC-filtret anslutet till ett IT-system, dvs. till ett icke direktjordat eller impedansjordat (över 30 ohm) jordat matningsnät. Annars kommer systemet att jordas via frekvensomriktarens EMC-filter inbyggda kondensatorer. Detta kan orsaka fara eller skada frekvensomriktaren.

Installera inte frekvensomriktaren med det interna EMC-filtret anslutet till ett hörnjordat TN-system eftersom det kan skada frekvensomriktaren.

Obs! När det interna EMC-filter är bortkopplat är frekvensomriktarens EMC-kompatibilitet avsevärt reducerad.

■ Jord till fas-varistor

Jord till fas-varistorn lämpar sig inte för användning i IT-system (icke-direktjordade system). Koppla bort jord till fas-varistorn före anslutning av frekvensomriktaren till matningsnätet. Se tabellen på sidan *128*.

SV



WARNING! Installera inte frekvensomriktaren med jord till fas-varistorn ansluten till ett IT-system (ett ojordat matningssystem eller ett högresistivt [över 30 ohm] jordat matningssystem). I så fall kan varistorkretsen skadas.

Kontrollera i tabellen nedan om du måste koppla bort EMC-filtret (EMC) eller jord till fas-varistor (VAR). För instruktioner, se sidan [129](#).

Storlekar	EMC-filtret (EMC)	Jord till fas-varistor (VAR)	Symmetriskt jordade TN-system (TN-S-system) ¹	Impedansjordade TN-system ²	IT-system (ojordade eller högresistivt jordade [$>30 \text{ ohm}$]) ³
R6...R9	EMC (2 skruvar)	-	Koppla inte bort	Koppla bort	Koppla bort
	-	VAR (1 skruv)	Koppla inte bort	Koppla inte bort	Koppla bort

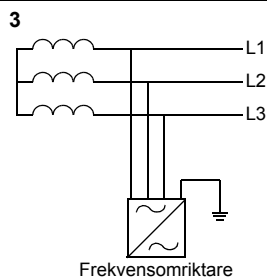
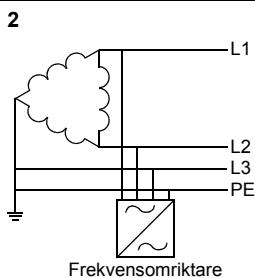
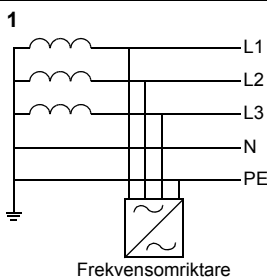

■ Koppla bort EMC-filtret eller jord till fas-varistorn vid behov

Koppla vid behov bort det interna EMC-filtret eller jord till fas-varistorn enligt följande:

1. Bryt matningen från frekvensomriktaren.
2. Öppna frontkåpan om den inte redan är öppen, se steg 5, IP21 och 5, IP55 i figur [R6...R9 Figures A](#) på sidan 157.
3. Koppla loss det interna EMC-filtret genom att skruva loss de två EMC-skruvarna.
4. Koppla bort jord till fas-varistorn genom att skruva loss varistorskruven.

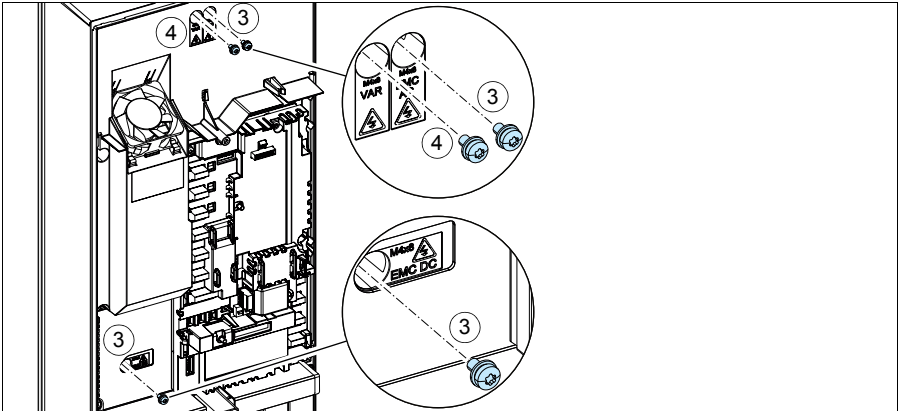
**R6-
R9****SV**

Anslut matningskablarna

Se figur C på sidan 157. Använd symmetrisk skärmad kabel för motoranslutning. Om kabelskärmen är den enda skyddsjordledaren för frekvensomriktaren eller motorn, se till att den har tillräcklig konduktivitet för skyddsjorden.

1. Sätt en varningsetikett för restspänningar på lokalt språk intill styrkortet.
- R6-
R9 2. Ta bort sidoplattorna på kabelgångslådan. Lossa fästskruvarna och dra ut väggarna.
3. Ta bort kåpan över kraftkabelanslutningarna genom att lossa klämmorna med en skruvmejsel och dra ut kåpan.
4. Öppna de förberedda hålen för kablarna som ska installeras.
5. Skär ett lämpligt hål genom gummigenomföringen. För upp kabeln genom kabelgenomföringen.
6. Förbered ändarna på den inkommande matnings- och motorkabeln så som illustreras i figuren. **Obs!** Den frilagda skärmen ska jordas 360°. Markera stumpen från skärmen som PE-ledare med gul och grön färg.
7. För kablarna genom hålen i bottenplattan och fäst gummigenomföringarna i hålen (motorkabeln till höger och matningskabeln till vänster).
8. Skala motorkabeln:
 - Jorda skärmarna 360° runt om under jordningsöverfallen (8a).
 - Anslut den tvinnade kabelskärmänden till jordplintarna (8b).
 - Anslut kabelns fasledare till anslutningarna T1/U-, T2/V- och T3/W. Dra åt skruvarna till de åtdragningsmoment som anges i figuren nedan (8c). **Obs!** Fasledarna (R8, R9) är pluggbara.
9. Anslut matningskabeln som i steg 8. Använd anslutningarna L1, L2 och L3.
10. R8...R9: Vid parallellkabelinstallation ska den andra jordningsplåten för de parallella matningskablarna installeras. Upprepa steg 5...9.
11. Montera jordningsplåten för styrkablarna.
12. Sätt tillbaka kåpan över kraftanslutningarna.
- SV 13. Fixera kablarna mekaniskt utanför enheten.
14. Jorda motorkabelskärmen vid motoränden. För att minimera den radiofrekventa strålningen, jorda motorkabelskärmen 360° runt om vid genomföringen i motorns anslutningslåda

Anslut styrkablarna

Se figur *D* på sidan 158. Den visar ett exempel med en analog signalkabel och en digital signalkabel. Gör anslutningarna enligt den standardkonfiguration som används. Standardanslutningarna för den förvalda HVAC-konfigurationen visas i avsnittet *Förvalda I/O-anslutningar* på sidan 132.

Exempel på anslutning av en analog signalkabel:

1. Skär ett lämpligt hål i gummigenomföringen i anslutningslådans underdel och skjut upp kragen på kabeln. För kabeln genom ett hål i bottenplattan och fäst kragen i hålet.
2. Jorda den skalade yttre kabelskärmen 360 grader under jordningsklämman. Kabeln ska annars vara skalad och kopplas samman så nära styrkortens plintar som möjligt. För analoga signalkablar, jorda även ledarparens skärmar och jordningskabeln vid SCR1-anslutningen. Fixera kablarna mekaniskt med klämmor under styrkortet.
3. Dra kablarna så som visas i figuren.
4. Anslut ledarna till sina respektive plintar på styrkortet och dra åt till 0,5...0,6 Nm.
5. Dra alla styrkablar till de medföljande kabelmonteringarna.
6. Placera de oanvända gummigenomföringarna på hålen i genomföringsplåten.

**R6-
R9****SV**

Förvalda I/O-anslutningar

Förvalda I/O-anslutningar för den förvalda HVAC-konfigurationen visas nedan.

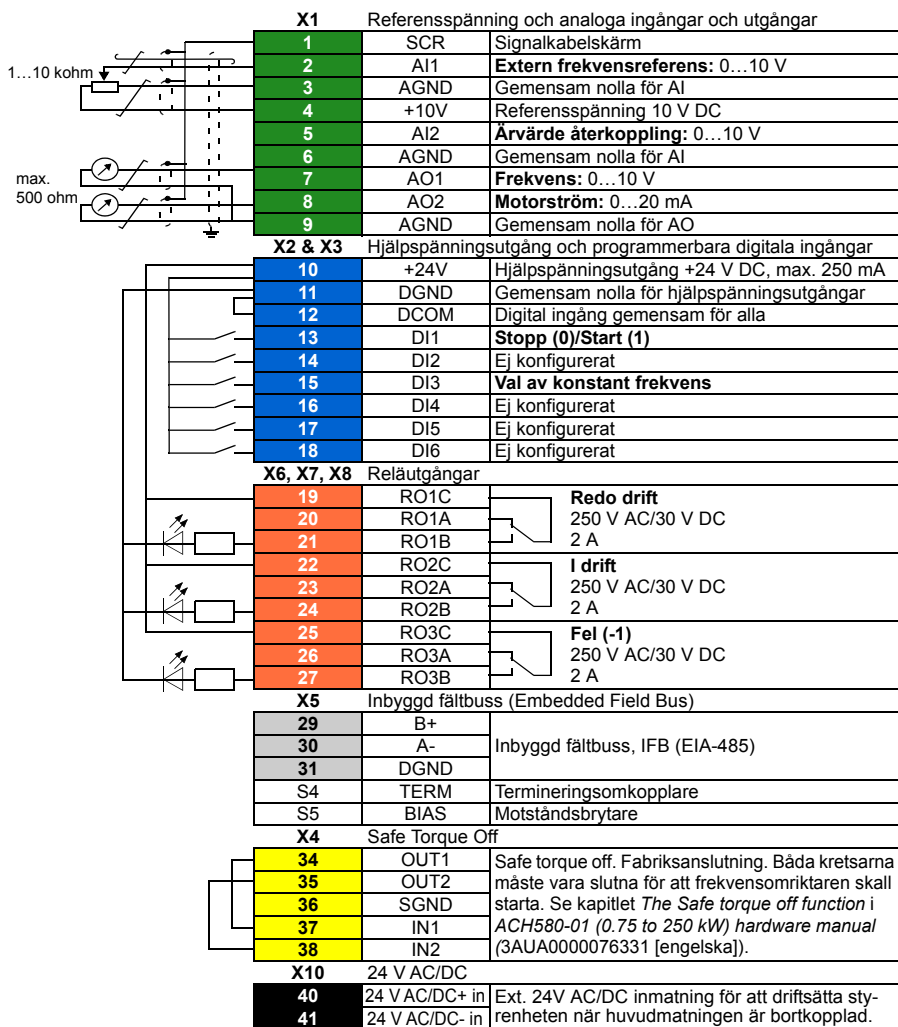
R6-
R9

SV

Total belastningskapacitet för hjälpsspänningsutgång +24 V (X2:10) är 6,0 W (250 mA/24 V DC).

Ledardimensioner: 0,14...2,5 mm² (26...16 AWG): Alla plintar

Atdragningsmoment: 0,5...0,6 N

Installera tillvalsmoduler, om det finns några

Se kapitel *Electrical installation* i *ACH580-01 (0.75 to 250 kW) hardware manual* (3AUA0000076331 [engelska]).

Installera sidoplattarna och kåporna

Se figur *R6...R9 Figures E* på sidan 159.

R6-
R9

IP21

1. Sätt tillbaka sidoplattorna på kabelingångslådan. Dra åt skruvarna med en skruvmejsel.
2. Dra kabelingångslådans kåpa på modulen från undersidan tills kåpan knäpps fast.
3. Sätt tillbaka modulkåpan. Dra åt de två skruvarna med en skruvmejsel.

IP55

1. Sätt tillbaka modulkåpan. Dra åt de två skruvarna med en skruvmejsel.

Idrifttagningsinstruktioner finns i kapitel *SV – Snabbguide för idrifttagning* på sidan 229.

SV

R6-
R9

SV

TR – R6...R9 Hızlı kurulum kılavuzu

Bu kılavuzda sürücünün nasıl kurulacağı kısaca anlatılmaktadır. Kurulum hakkında tam bilgi için, bkz. *ACH580-01 (0.75 to 250 kW) hardware manual* (3AUA0000076331 [İngilizce]). Başlatma talimatları için, bkz. bölüm [TR – Hızlı başlatma kılavuzu](#) sayfa 235.

Çevrimiçi kılavuzu okumak için www.abb.com/drives/documents adresine gidin ve belge numarasını arayın.

R6-
R9

Güvenlik talimatlarına uyun



UYARI! Bu talimatlara uyun. Bunlara uymamanız halinde ölüm ya da yaralanma söz konusu olabilir veya ekipman zarar görebilir.

- Kalifiye bir elektrikçi değilseniz, elektrik kurulum işlemi yapmayın.
- Ana güç verildiğinde sürücü, motor kablosu ve motor üzerinde çalışma yapmayın. Sürücü zaten giriş gücüne bağlıysa giriş gücü bağlantısını kestikten sonra 5 dakika bekleyin.
- Sürücü veya harici kontrol devrelerine enerji verilirken kontrol kabloları üzerinde çalışma yapmayın.
- Sürücüyü kaldırırken, sürücünün kaldırma gözlerini kullanın. Sürücüyü yana yatırmayın. Sürücü ağır ve ağırlık merkezi yüksektir. Devrilen sürücü fiziksel yaralanmalara neden olabilir.
- Delik ve frezelerdeki kalıntıların kurulum sırasında sürücü içine girmemesine dikkat edin.
- Sürücünün altındaki zeminin ve sürücünün kurulduğu yerdeki duvarın yanmaz nitelikte olduğundan emin olun.

Kondansatörlerin yenilenmesinin gerekip gerekmediğini kontrol edin

Sürücüye bir yıldan uzun süre güç verilmemişse (depolanmışsa veya kullanılmıyorsa) kondansatörleri yenilemelisiniz.

Üretim tarihini, sürücünün üzerindeki tip tanımlama etiketinde bulabileceğiniz seri numarasından belirleyebilirsiniz. Seri numarası MYYWWRXXXX biçimindedir. YY ile WW üretim yılını ve haftasını gösterir.

YY: 2013, 2014, 2015, ... için 13, 14, 15, ...

WW: hafta 1, hafta 2, hafta 3 için ...01, 02, 03 ...

TR

Kondansatörlerin yenilenmesi ile ilgili bilgi için, bkz. *Converter module capacitor reforming instructions* (3BFE64059629 [İngilizce]), İnternet'te www.abb.com/drives/documents adresinde bulunmaktadır.

Güç kablolarını seçin

Sürücünüzün tip belirleme etiketinde verilen nominal akımı taşımak için güç kablolarını yerel yönetmeliklere uygun olarak boyutlandırın.

R6-
R9

Soğutmayı sağlayın

Isı dağıtımı için, bkz. tablo I, sayfa 13 (UL: tablo II, sayfa 13). Sürücünün izin verilen çalışma sıcaklığı aralığı -15 ila +50°C (+5 ila +122°F) arasındadır. Yoğuşmaya veya donmaya izin verilmez. Ortam sıcaklığı ve değer kaybı hakkında daha fazla bilgi için *ACH580-01 (0.75 to 250 kW) hardware manual* (3AUA0000076331 [İngilizce]) kılavuzu *Technical data* (Teknik veriler) bölümüne bakın.

Sürücüyü ve giriş güç kablosunu koruyun

Sigortalar için, bkz. tablo III, IV ve V, sayfa 14 ve 14.

gG sigorta kullanırsanız, sigortanın çalışma süresinin 0,5 saniyenin altında olduğundan emin olun. Yerel düzenlemelere uyun.

Sürücüyü duvara kurun

 **Uyarı!** Sürücü modülü ağırdır (42 - 103 kg/93 - 227 lb). Uygun bir kaldırma aleti kullanın. Modülü elle kaldırmayın. Duvarın ve sabitleme cihazlarının ağırlığı taşıyabildiğinden emin olun.

Bkz. şekil *R6...R9 Figures A*, sayfa 157.

Güç kablolarının ve motorun yalıtımını kontrol edin

Sürücüye bağlamadan önce yerel yasalara uygun olarak giriş kablosunun yalıtımını kontrol edin.

Bkz. şekil B, sayfa 157.

1. Sürücüye bağlamadan önce motor kablosunun ve motorun yalıtımını kontrol edin. 1000 VDC ölçüm gerilimi kullanarak faz iletkenleri arasındaki yalıtım direncini ve her bir faz iletkeni ile Koruyucu Topraklama iletkeni arasındaki yalıtım direncini ölçün. Tipik bir motorun yalıtım direnci 100 Mohm'u geçmelidir (referans değer, 25°C'de veya 77°F'ta). Motorların yalıtım direnci için üreticinin talimatlarına bakın.

R6-
R9

Not: Motor muhafazası içindeki nem yalıtım direncini düşürecektir. Eğer nemden şüphe edilirse, motoru kurutun ve ölçümü tekrarlayın.

IT (topraklamasız) ve TN sistemleriyle uyumluluğu kontrol edin

■ EMC filtresi

Dahili EMC filtresi IT (topraklamasız) sistemde veya TN sisteminde kullanıma uygun değildir. Sürücüyü besleme şebekesine bağlamadan önce EMC filtresinin bağlantısını kesin. 138. sayfadaki tabloyu kontrol edin.



UYARI! Bir IT sistemine (topraklamasız güç sistemi veya yüksek dirençli topraklamalı [30 ohm üzerinde] güç sistemi) dahili EMC filtresi bağlı olan sürücüyü takmayın, aksi halde sistem, EMC filtresi kondansatörleri yoluyla toprak potansiyeline bağlanır. Bu, tehlikeye veya sürücüde hasara neden olabilir.

TN sistemine dahili EMC filtresi bağlı olan sürücüyü takmayın, aksi halde sürücü hasar görecektir.

Not: Dahili EMC filtresi söküldüğünde, sürücünün EMC uyumluluğu oldukça azalır.

■ Toprak-faz varistörü

Toprak-faz varistörü bir IT (topraklamasız) sistemde kullanıma uygun değildir. Sürücüyü besleme şebekesine bağlamadan önce toprak-faz varistörünün bağlantısını kesin. 138. sayfadaki tabloyu kontrol edin.



UYARI! Toprak-faz varistörü bağlıyken sürücüyü IT sistemine (topraklamasız güç sistemi veya yüksek dirençli topraklamalı [30 ohm üzerinde] güç sistemi) bağlamayın, aksi halde varistör devresi hasar görebilir.

TR

EMC filtresinin (EMC) veya toprak-faz varistörünün (VAR) bağlantısını kesmenin gerekli olup olmadığını aşağıdaki tablodan kontrol edin. Bunun nasıl yapılacağı hakkında talimatlar için, bkz. sayfa 139.

Kasa boyutları	EMC filtresi (EMC)	Toprak-faz varistörü (VAR)	Simetrik olarak topraklanmış TN sistemleri (TN-S sistemleri) ¹	TN sistemleri ²	IT sistemleri (topraklanmamış veya yüksek dirençli olarak topraklanmış [$>30 \text{ ohm}$]) ³
R6...R9	EMC (2 vida)	-	Bağlantıyı kesme	Bağlantıyı kes	Bağlantıyı kes
	-	VAR (1 vida)	Bağlantıyı kesme	Bağlantıyı kesme	Bağlantıyı kes

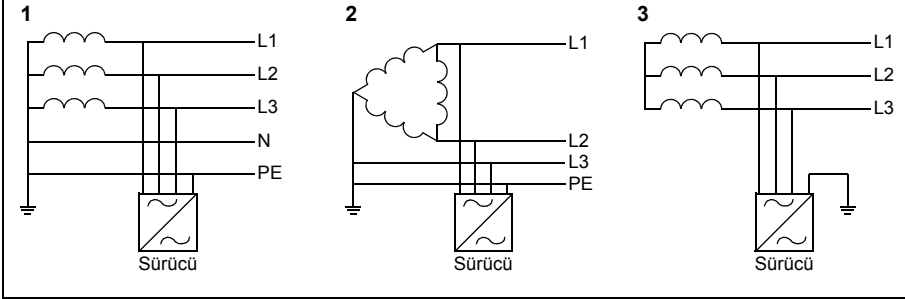

■ Gerekirse, EMC filtresinin veya toprak-faz varistörünün bağlantısını kesin

Gerekirse, dahili EMC filtresinin veya toprak-faz varistörünün bağlantısını kesmek için, aşağıdakileri yapın:

1. Sürücünün gücünü kesin.
2. Açılmamışsa ön kapağı açın, bkz. adım 5, IP21 ve 5, IP55, şekil [R6...R9 Figures A](#), sayfa [157](#).
3. Dahili EMC filtresinin bağlantısını kesmek için, iki EMC vidasını sökün.
4. Toprak-faz varistörünün bağlantısını kesmek için, varistör vidasını çıkarın.

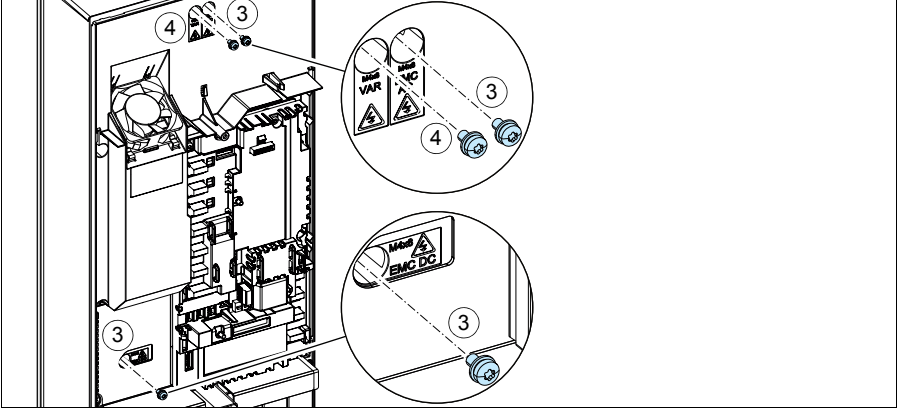
**R6-
R9****TR**

Güç kablolarını bağlayın

Bkz. şekil C, sayfa 157. Motor kablosu için simetrik blendajlı kablo kullanın. Kablo blendajı, sürücünün veya motorun tek PE iletkeniyse, blendajın iletkenliğinin PE için yeterli olduğundan emin olun.

1. Yerel dildeki kaçak gerilim uyarı etiketini kontrol panelinin yan tarafına yapıştırın.
- R6-R9** 2. Kablo giriş kutusunun yan plakalarını sökün. Sabitleme vidalarını gevşetin ve duvarları dışarı doğru kaydırın.
3. Bir tornavida ile klipsleri açıp kaldırarak ve kapağı dışarı doğru çekerek güç kablosu terminallerinin üzerindeki kapağı sökün.
4. Takılacak kablolar için delik açın.
5. Lastik rondelaya uygun boyutlu bir delik açın. Rondelayı kablonun üzerine doğru kaydırın.
6. Giriş gücü kablosunun ve motor kablosunun uçlarını şekilde gösterildiği gibi hazırlayın. **Not:** Çıplak blendaj 360 derece topraklanacaktır. Blendajdan yapılan örgüyü, sarı ve yeşil rengi kullanarak bir PE iletkeni olarak işaretleyin.
7. Kabloları, alt plakanın deliklerinden geçirin ve rondelaları deliklere takın (motor kablosu sağda ve giriş kablosu solda).
8. Motor kablosunu bağlayın:
 - Blendajlı topraklama kelepçesi altında 360 derece topraklayın (8a).
 - Kablonun bükümlü blendajını topraklama terminaline bağlayın (8b).
 - Kablonun faz iletkenlerini T1/U, T2/V ve T3/W terminallerine bağlayın. Vidaları aşağıdaki şekilde belirtilen tork değerlerinde sıkın (8c). **Not:** Faz iletkenleri (R8, R9) sökülebilir.
9. Giriş güç kablosunu 8. adımdaki gibi bağlayın. L1, L2 ve L3 terminallerini kullanın.
10. **R8...R9:** Paralel kablo kurarsanız, paralel güç kabloları için ikinci topraklama rafını kurun. **5...9** adımlarını tekrarlayın.
11. Kontrol kabloları için topraklama rafını takın.
12. Kapağı güç terminallerinin üzerine tekrar takın.
13. Ünitenin dışında yer alan kabloları mekanik olarak sabitleyin.
- TR** 14. Motor kablo blendajını motor tarafında topraklayın. Minimum radyo frekansı parazitini için motor kablo blendajını, motor terminal kutusunun geçişinde 360 derece topraklayın.

Kontrol kablolarını bağlayın

Bkz. şekil *D*, sayfa 158. Biri analog sinyal kablolu ve diğeri dijital sinyal kablolu bir örnek gösterilmiştir. Bağlantıları, kullanılan varsayılan yapılandırmaya göre yapın. HVAC varsayılan yapılandırmasının varsayılan bağlantıları *Varsayılan G/Ç bağlantıları* bölümü 142. sayfada gösterilmektedir.

Bir analog sinyal kablosunu bağlama örneği:

1. Lastik rondelaya uygun boyutlu bir delik açın ve rondelayı kablonun üstüne kaydırın. Kabloyu alt plaka deliğinin içinden geçirin ve rondelayı deliğe takın.
2. Soyulmuş dış kablo blendajını topraklama kelepçesinin altında 360 derece topraklayın. Kabloyu, kontrol paneli terminallerinin mümkün olduğunca yakınına kadar soyulmamış halde tutun. Analog giriş kabloları için kablo çifti blendajlarını ve topraklama kablosunu da SCR1 terminalinde topraklayın. Kabloları kontrol panelinin altındaki kelepçelerde mekanik olarak sabitleyin.
3. Kabloyu şekilde gösterildiği gibi yönlendirin.
4. İletkenleri kontrol panelinin ilgili terminallerine bağlayın ve 0,5...0,6 N·m (0,4 lbf·ft) değerinde sıkın.
5. Tüm kontrol kablolarını sağlanan kablo bağlama yuvalarına bağlayın.
6. Kullanılmamış lastik rondelaları geçiş plakasının deliklerine yerleştirin.

R6-
R9

TR

Varsayılan G/Ç bağlantıları

HVAC varsayılan yapılandırmasının varsayılan G/Ç bağlantıları aşağıda gösterilmiştir.

R6-
R9

X1 Referans gerilimi ve analog girişlerle çıkışlar		
1	SCR	Sinyal kablosu blendajı (ekran)
2	AI1	Çıkış frekansı/hızı referansı: 0...10 V
3	AGND	Analog giriş devresi ortak ucu
4	+10V	Referans gerilimi 10 VDC
5	AI2	Gerçek geribildirim: 0...10 V
6	AGND	Analog giriş devresi ortak ucu
7	AO1	Çıkış frekansı: 0...10 V
8	AO2	Çıkış akımı: 0...20 mA
9	AGND	Analog çıkış devresi ortak ucu

1...10 kohm

maks. 500 ohm

X2 ve X3 Yrd. gerilim çıkışı ve programlanabilir dijital girişler		
10	+24V	Yrd. gerilim çıkışı +24 VDC, maks. 250 mA
11	DGND	Yrd. gerilim çıkışı ortak ucu
12	DCOM	Tümü için dijital giriş ortak ucu
13	DI1	Stop (0) / Start (1)
14	DI2	Yapılandırılmadı
15	DI3	Sabit frekans/hız seçimi
16	DI4	Yapılandırılmadı
17	DI5	Yapılandırılmadı
18	DI6	Yapılandırılmadı

X6, X7, X8 Röle çıkışları		
19	RO1C	Çalışmaya hazır 250 VAC / 30 VDC 2 A
20	RO1A	
21	RO1B	Çalışıyor 250 VAC / 30 VDC 2 A
22	RO2C	
23	RO2A	Hata (-1) 250 VAC / 30 VDC 2 A
24	RO2B	
25	RO3C	
26	RO3A	
27	RO3B	

X5 Dahili fieldbus		
29	B+	Dahili fieldbus, EFB (EIA-485)
30	A-	
31	DGND	
S4	TERM	Sonlandırma anahtarı
S5	BIAS	Bias dirençleri anahtarı

X4 Güvenli moment kapatma		
34	OUT1	Güvenli moment kapatma. Fabrika bağlantısı. Sürücünün başlaması için her iki devre kapatılmalıdır. Bkz. ACH580-01 (0.75 to 250 kW) hardware manual (3AUA0000076331 [İngilizce]) kılavuzu, <i>The Safe torque off function</i> (Güvenli moment kapatma fonksiyonu) bölümü.
35	OUT2	
36	SGND	
37	IN1	
38	IN2	

X10 24 VAC/DC		
40	24 V AC/DC+ in	Harici 24 VAC/DC girişi, ana beslemenin bağlantısı kesildiğinde kontrol ünitesine güç vermek içindir.
41	24 VAC/DC- in	

TR

Yardımcı voltaj çıkışı +24 V (X2:10) için toplam yük kapasitesi 6,0 W'tır (250 mA / 24 VDC).

Kablo boyutları: 0,14...2,5 mm² (26...16 AWG): Tüm terminaller

Sıkma momentleri: 0,5...0,6 N·m (0,4 lbf·ft)

Varsa isteğe bağlı modülleri kurun

Bkz. *ACH580-01 (0.75 to 250 kW) hardware manual* (3AUA0000076331 [İngilizce]) kılavuzu, *Electrical installation* (Elektrik kurulumu) bölümü.

Yan plakaları ve kapakları takın

Bkz. şekil *R6...R9 Figures E*, sayfa 159.

R6-
R9

IP21

1. Kablo giriş kutusunun yan plakalarını tekrar takın. Sabitleme vidalarını tornavidayla sıkın.
2. Modüldeki kablo giriş kutusunun kapağını kapak yerine oturana dek aşağıdan kaydırın.
3. Modül kapağını tekrar takın. İki sabitleme vidasını tornavidayla sıkın.

IP55

1. Modül kapağını tekrar takın. İki sabitleme vidasını tornavidayla sıkın.

Başlatma talimatları için, bkz. bölüm *TR – Hızlı başlatma kılavuzu* sayfa 235.

TR

R6-
R9

TR

ZH - R6...R9 快速安装指南

本指南简要介绍如何安装和启动变频器。如需了解完整的安装信息，请参阅 *ACH580-01 (0.75 to 250 kW) hardware manual* (3AUA0000076331 [英语])。有关启动说明，请参阅第 241 页的 *ZH - 快速启动指南* 一章。

如需阅读手册，请访问 www.abb.com/drives/documents，搜索文件编号。

R6-
R9

遵循安全指导



警告！ 请遵循这些指导。如果您忽略指导，可能会导致受伤、死亡或设备损坏：

- 如果您不是具有资格的电工，请勿进行电气安装工作。
- 当接上主电源时，切勿在变频器、电机电缆或电机上操作。如果变频器已经连接到了输入电源，请在断开输入电源后等待 5 分钟。
- 当变频器或外部控制电路连接了电源时，切勿操作控制电缆。
- 起吊变频器时请使用变频器的吊耳。不要将变频器倾斜。变频器很重，而且重心较高。翻倒的变频器可能会导致人身伤害。
- 在安装时，确保不让钻孔和研磨出的碎屑进入变频器。
- 确保变频器下方的地面和安装变频器的墙面是阻燃的。

检查电容是否需要重整

如果变频器已经有一年或更长时间未通电（存放或未用），则必须重整电容。

您可以从序列号来判断生产时间。序列号可以在变频器所贴的型号标签上找到。序列号的格式是 MYYWWRXXXX。YY 和 WW 以如下方式说明生产年份和周次：

YY: 13、14、15、... 分别代表 2013、2014、2015、...

WW: 01、02、03、... 分别代表第 1 周、第 2 周、第 3 周、...

有关电容重整的信息，请参阅互联网上的 *Converter module capacitor reforming instructions*（变频器模块电容重整说明）(3BFE64059629 [英语])，网址：
www.abb.com/drives/documents。

选择电缆

应根据当地规范选择能承载变频器型号标签上标称电流的电缆规格。

ZH

确保冷却

请参阅第 13 页上的表 I (UL : 第 13 页上的表 II) 了解散热信息。变频器的允许操作温度范围是 -15 到 +50°C (+5 到 +122°F)。不允许凝露或结霜。如需了解环境温度和降低额定值的更多信息，请参阅 *ACH580-01 (0.75 to 250 kW) hardware manual* (3AUA0000076331 [English]) 中 *Technical data* (技术数据) 一章。

R6-
R9

保护变频器和输入电缆

有关保险丝的信息请参阅第 14 和第 14 页的表 III、IV 和 V。

如果使用 gG 熔断器，请确保熔断器的熔断时间少于 0.5 秒。遵循当地法规。

在墙上安装变频器



警告！ 变频器模块很重 (42 到 103 kg / 93 到 227 lb)。请使用合适的起吊设备。切勿人工抬起变频器模块。确保墙壁和固定装置能承载此重量。

请参阅第 157 页的图 *R6...R9 Figures A*。

检查供电电缆和电机的绝缘

在将输入电缆连接到变频器前，请按当地法规检查其绝缘。

请参阅第 157 的图 B。

1. 在将电机电缆和电机连接到变频器前，请检查其绝缘。使用 1000 V 直流测量各相导线之间的绝缘电阻，然后测量每相导线与保护性接地导线之间的绝缘电阻。典型电机的绝缘电阻必须超过 100 Mohm（参照值为 25°C 或 77°F 时测得）。对于其他电机的绝缘电阻，请参阅其制造商的说明。

注：电机外壳内部的湿气会降低绝缘电阻。如果湿气长期存在，请干燥电机后再次测量。

R6-
R9

检查与 IT（浮地）和角接地的 TN 系统的兼容性

■ EMC 滤波器

内置 EMC 滤波器不适用于 IT（浮地）系统或角接地的 TN 系统。在将变频器连接到电网前断开 EMC 滤波器的连接。查看第 148 页的表。



警告！ 请勿将连接了内置 EMC 滤波器的变频器安装在 IT 系统（浮地电源系统或高阻抗接地系统 [超过 30 ohm] 的电源系统），否则系统将可能会通过变频器的 EMC 滤波器电容连接到接地线。这可能会导致危险或损坏变频器。

请勿将连接了内置 EMC 滤波器的变频器安装在角接地的 TN 系统，否则可能会损坏变频器。

注：不连接内置 EMC 滤波器，变频器的 EMC 兼容性会显著降低。

■ 压敏电阻

压敏电阻不适用于 IT（浮地）系统。在将变频器连接到电网前断开压敏电阻的连接。查看第 148 页的表。



警告！ 安装变频器时请勿将压敏电阻连接到 IT 系统（未接地电源系统或高阻抗接地系统 [超过 30 ohm] 的电源系统），否则会损坏压敏电阻的电路。

如须断开 EMC 滤波器 (EMC) 或压敏电阻 (VAR)，请查看下表。具体操作说明请参阅第 149 页。

外形尺寸	EMC 滤波器 (EMC)	压敏电阻 (VAR)	对称接地 TN 系统 (TN-S 系统) ¹	角接地 TN 系统 ²	IT 系统 (浮地或高阻抗接地系统 [$>30 \text{ ohms}$]) ³
R6...R9	EMC (2 个螺钉))	-	不断开	断开	断开
	-	VAR (1 个螺钉))	不断开	不断开	断开

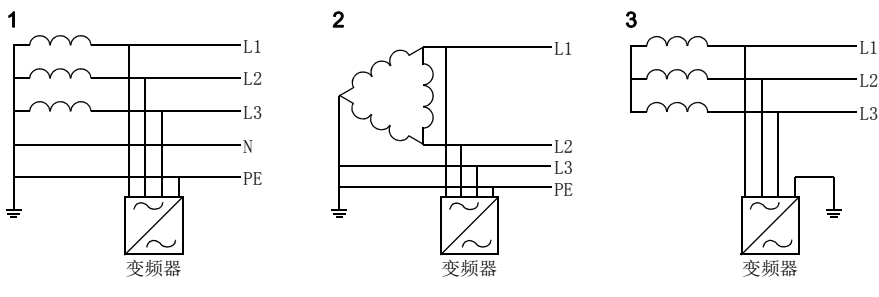

■ 断开 EMC 滤波器或压敏电阻（必要时）

如果必要时要断开内置 EMC 滤波器或压敏电阻，请执行以下操作：

1. 关断变频器电源。
2. 打开前盖（如果尚未打开），请参阅第 157 页图 R6...R9 Figures A 上的步骤 5，IP21 和步骤 5，IP55。
3. 卸下两颗 EMC 螺钉，断开内置 EMC 滤波器。
4. 卸下载敏电阻螺钉，断开压敏电阻。

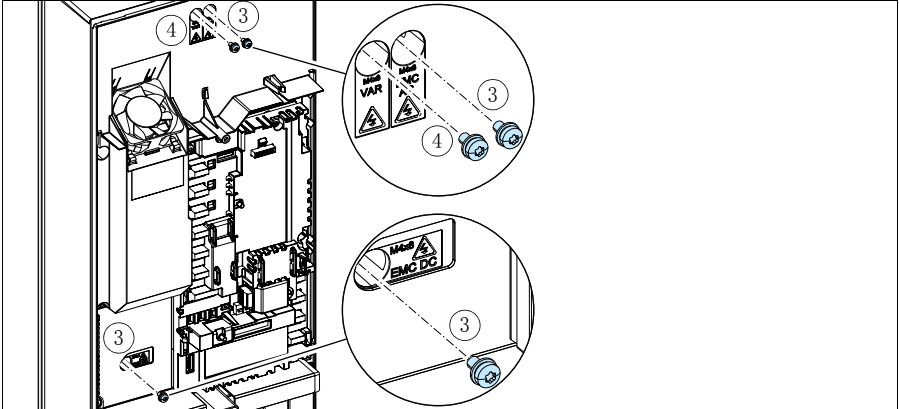

R6-
R9

连接电缆

请参阅第 157 页的图 C。机电电缆请使用对称屏蔽线。如果屏蔽电缆为变频器或电机的唯一保护接地线，请确保地线有足够的导电能力。

1. 将本地语言的残余电压警告贴纸贴在控制电路板旁。
2. 卸下电缆接入盒的侧板：松开紧固螺钉并把侧板滑出。
3. 用螺丝刀松开搭扣，并将护罩拉出，卸下供电电缆端子上的护罩。
4. 在遮蔽盖板上对应安装电缆的位置打孔。
5. 在橡胶绝缘圈上切出足够大的孔。将绝缘圈套入电缆。
6. 如图所示准备好供电电缆和电机的两端。**注：**将屏蔽线裸线做 360 度接地。将黄绿色双绞线屏蔽线标记为保护接地线。
7. 将电缆从底板的孔中穿过并将绝缘圈固定到孔上（电机电缆在右，输入电缆在左）。
8. 连接机电电缆：
 - 在接地夹下将屏蔽层做 360 度接地 (8a)。
 - 将电缆的双绞线屏蔽层连接到接地端子 (8b)。
 - 将电缆的相线连接到 T1/U、T2/V 和 T3/W 端子。按图中给出的力矩拧紧螺钉 (8c)。**注：**相线 (R8, R9) 是可拆卸的。
9. 按步骤 8 中的方法连接供电电缆。使用端子 L1、L2 和 L3
10. **R8...R9：**如果您要平行安装，请安装平行电缆的第二个接地支架。重复步骤 5...9。
11. 安装控制电缆的接地支架。
12. 在电源端子上装回遮蔽盖板。
13. 将导线在变频器单元外机械紧固。
14. 在电机端将机电电缆屏蔽层接地。为实现最小的射频干扰，在电机接线盒的穿孔部分将机电电缆屏蔽层做 360 度接地。

R6-
R9

连接控制电缆

请参阅第 158 页的图 D。图中所示为一根模拟信号电缆和一根数字信号电缆的示例。请按所使用的默认配置进行连接。HVAC 默认配置的默认连接见第 152 页的 [默认 I/O 连接](#) 一节。

模拟信号电缆连接示例：

1. 在橡胶绝缘圈上切一个足够大的孔，然后将绝缘圈套入电缆。将电缆从底板的孔中穿过并将绝缘圈固定到孔上。
2. 将剥开的电缆外屏蔽层在接地夹下做 360 度接地。靠近控制电路板端子的电缆剥开部分要尽可能少。对于模拟信号电缆，在 SCR1 端子处将成对电缆屏蔽和接地线也做接地。将电缆以机械方式固定在控制板下的夹子上。
3. 如图所示进行布线。
4. 将导线连接到控制板的对应端子上，并紧固到 0.5...0.6 N·m (0.4 lbf·ft)。
5. 将全部控制电缆都绑到提供的电缆捆绑架上。
6. 将未使用的橡胶绝缘圈装回到穿孔板的孔上。

R6-
R9

默认 I/O 连接

HVAC 默认配置的默认 I/O 连接如下所示。

R6-
R9

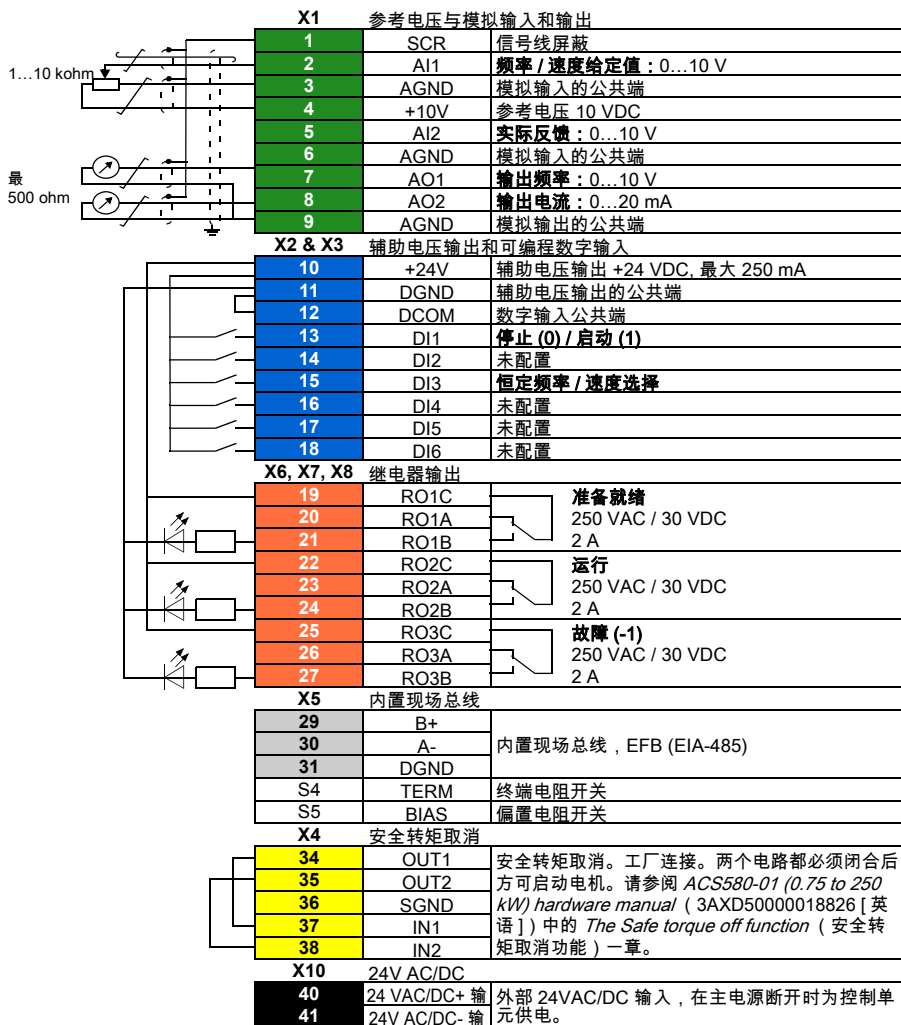

ZH

辅助电压输出 +24V (X2:10) 的总负载能力为 6.0 W (250 mA / 24 VDC)。

电缆规格: 0.14...2.5 mm² (26...16 AWG): 所有终端

紧固力矩: 0.5...0.6 N·m (0.4 lbf·ft)

安装可选模块

请参阅 *ACH580-01 (0.75 to 250 kW) hardware manual* (3AUA0000076331 [英语]) 中的 *Electrical installation* (电气安装) 一章。

安装侧板和盖板

请参阅第 159 页的图 *R6...R9 Figures E*。

R6-
R9

IP21

1. 装回电缆接入盒的侧板。用螺丝刀将紧固螺钉拧紧。
2. 从下方将模块上的接线盒盖板滑入，直到盖板牢牢卡住。
3. 装回模块盖板。用螺丝刀将两颗紧固螺钉拧紧。

IP55

1. 装回模块盖板。用螺丝刀将两颗紧固螺钉拧紧。

有关启动说明，请参阅第 241 页的 *ZH - 快速启动指南* 一章。

R6-
R9

ZH

Compliance with the European Machinery Directive 2006/42/EC

Declaration of conformity



EU Declaration of Conformity

(According to Machinery Directive 2006/42/EC)

R6-
R9

We

Manufacturer: ABB Oy, Drives
Address: Hiomotie 13, P.O Box 184, 00381 Helsinki, Finland.

hereby declare that the product

ACH580-01 (frame sizes R0, R1, R2, R3, R4, R5, R6, R7, R8 and R9)

with regard to the following safety function

Safe torque off

fulfils all the relevant safety component requirements of EC Machinery Directive 2006/42/EC, when the listed safety function is used for safety component functionality.

The following harmonized standards below were used:

EN 61800-5-2: 2007	<i>Adjustable speed electrical power drive systems – Part 5-2: Safety requirements - Functional</i>
EN 62061: 2015	<i>Safety of machinery – Functional safety of safety-related electrical, electronic and programmable electronic control systems</i>
EN ISO 13849-1: 2008 + AC: 2009	<i>Safety of machinery – Safety-related parts of control systems. Part 1: General requirements</i>
EN ISO 13849-2: 2012	<i>Safety of machinery – Safety-related parts of the control systems. Part 2: Validation</i>
EN 60204-1:2006 + A1:2009 + AC:2010	<i>Safety of machinery – Electrical equipment of machines – Part 1: General requirements</i>

Other used standards:

IEC 61508 ed. 2: 2010	Functional safety of electrical / electronic / programmable electronic safety-related systems
-----------------------	---

The products referred in this Declaration of Conformity fulfil the relevant provisions of the Low Voltage Directive 2006/95/EC and EMC Directive 2004/108/EC. Declaration of conformity according to these directives is available from the manufacturer.

Person authorized to compile the technical file:

Name: Risto Mynttinen
Address: P.O. Box 184, FIN-00381 Helsinki, Finland

Helsinki, 2016-02-10

Tuomo Höysniemi
Vice President
ABB Oy

R6-
R9

R6...R9 Figures A

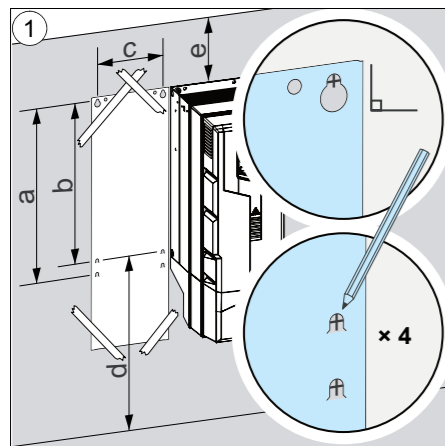

	R6	R7	R8	R9
a (mm/in)	571/22.5	623/24.5	701/27.6	718/28.3
b (mm/in)	531/20.9	583/22.9	658/25.9	658/25.9
c (mm/in)	213/8.4	245/9.7	263/10.4	345/13.6
d > (mm/in)	300/11.8	300/11.8	300/11.8	300/11.8
e > (mm/in)	200/7.9	200/7.9	200/7.9	200/7.9
kg/lb	IP21 42/93	IP21 54/119	IP21 69/152	IP21 97/214
	IP55 43/95	IP55 56/124	IP55 77/170	IP55 103/227

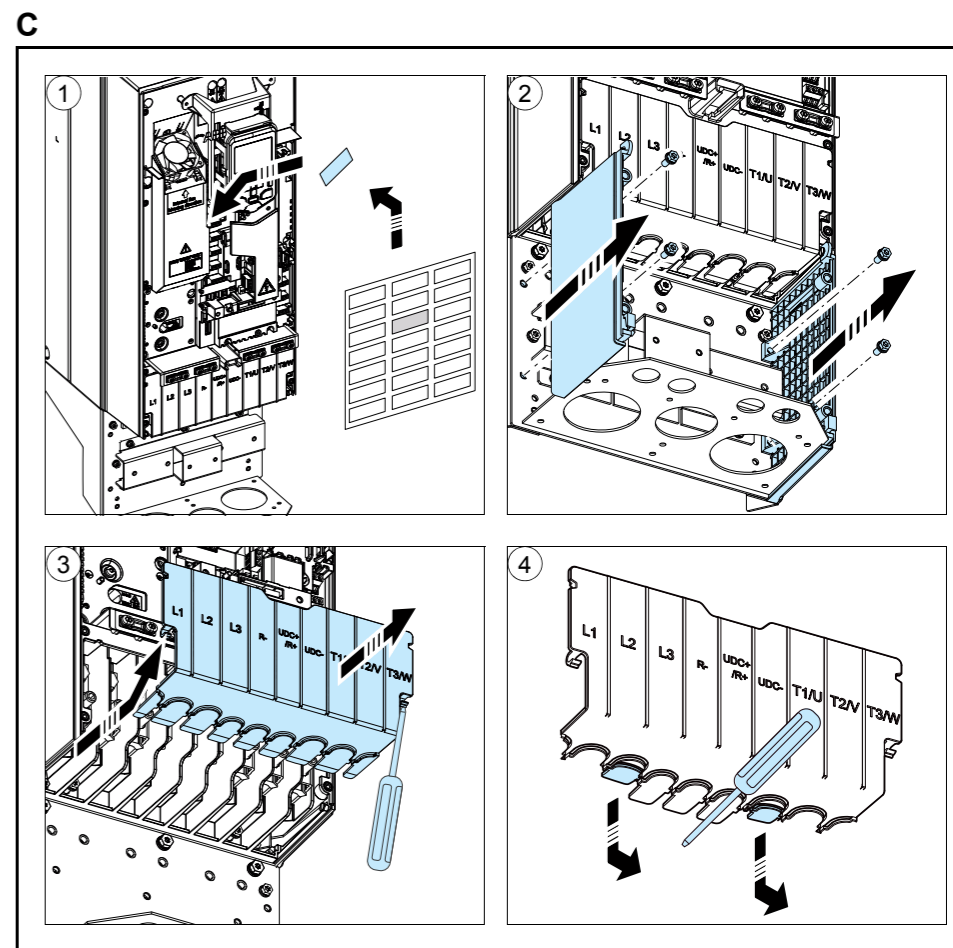
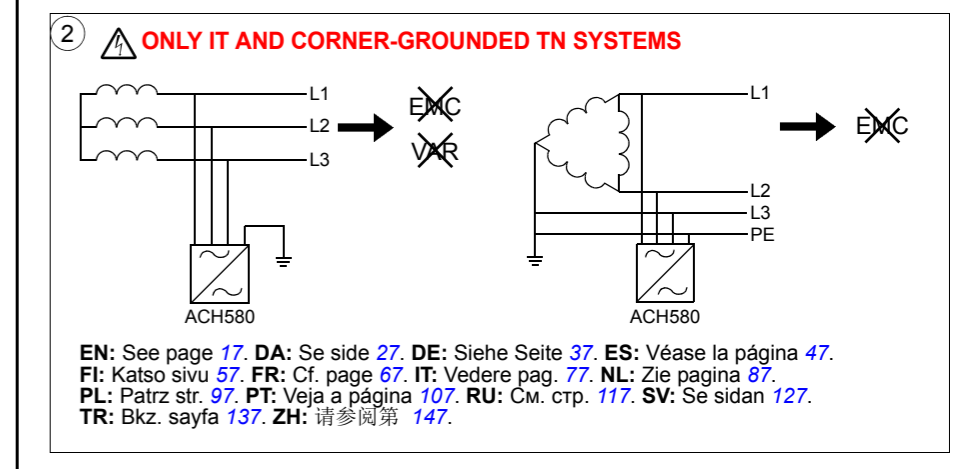
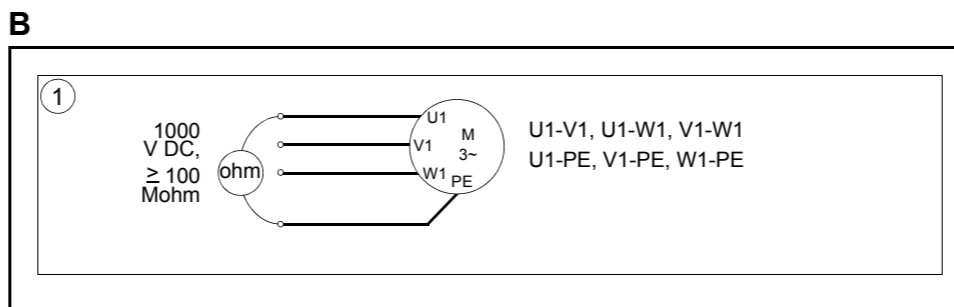
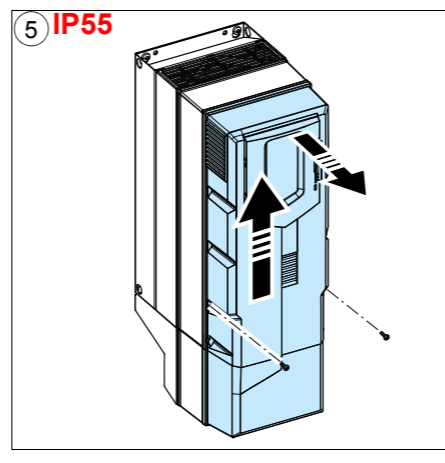
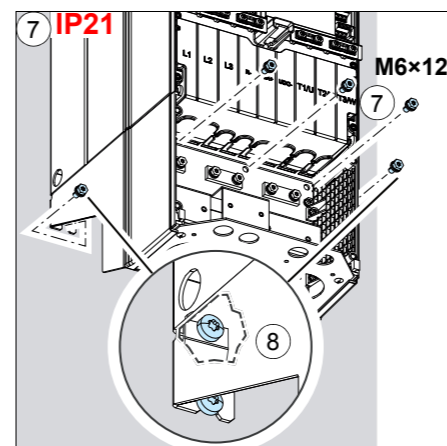
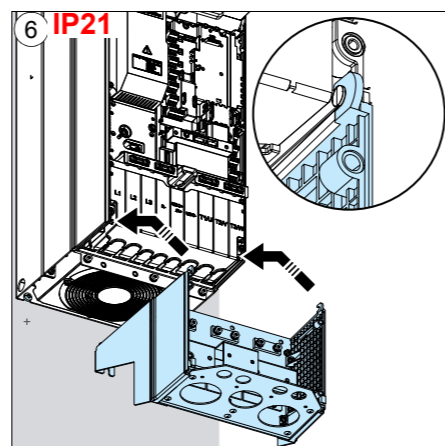
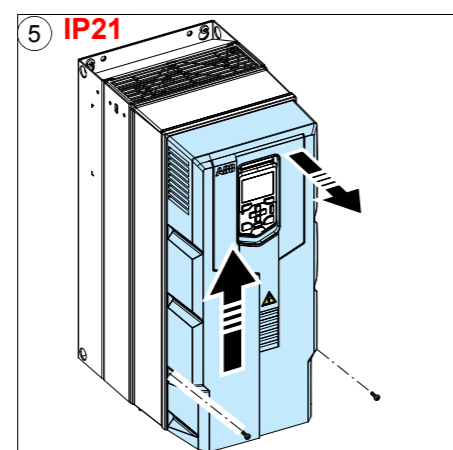
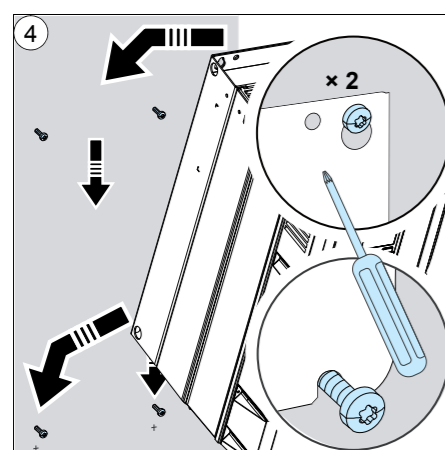
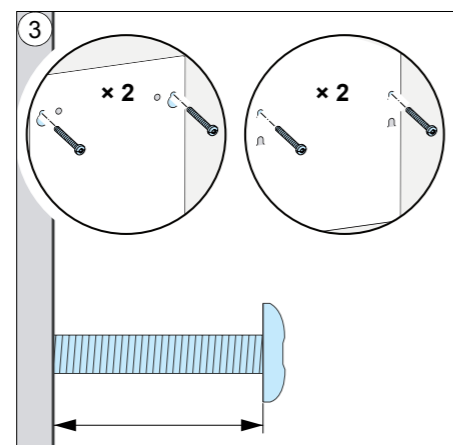
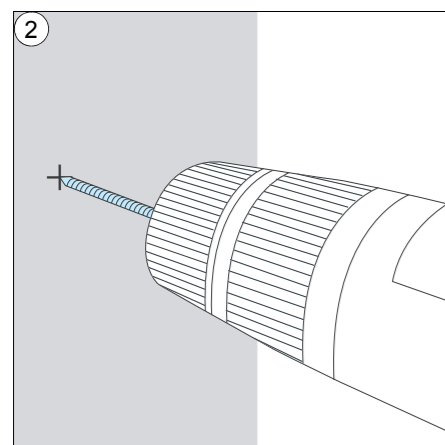

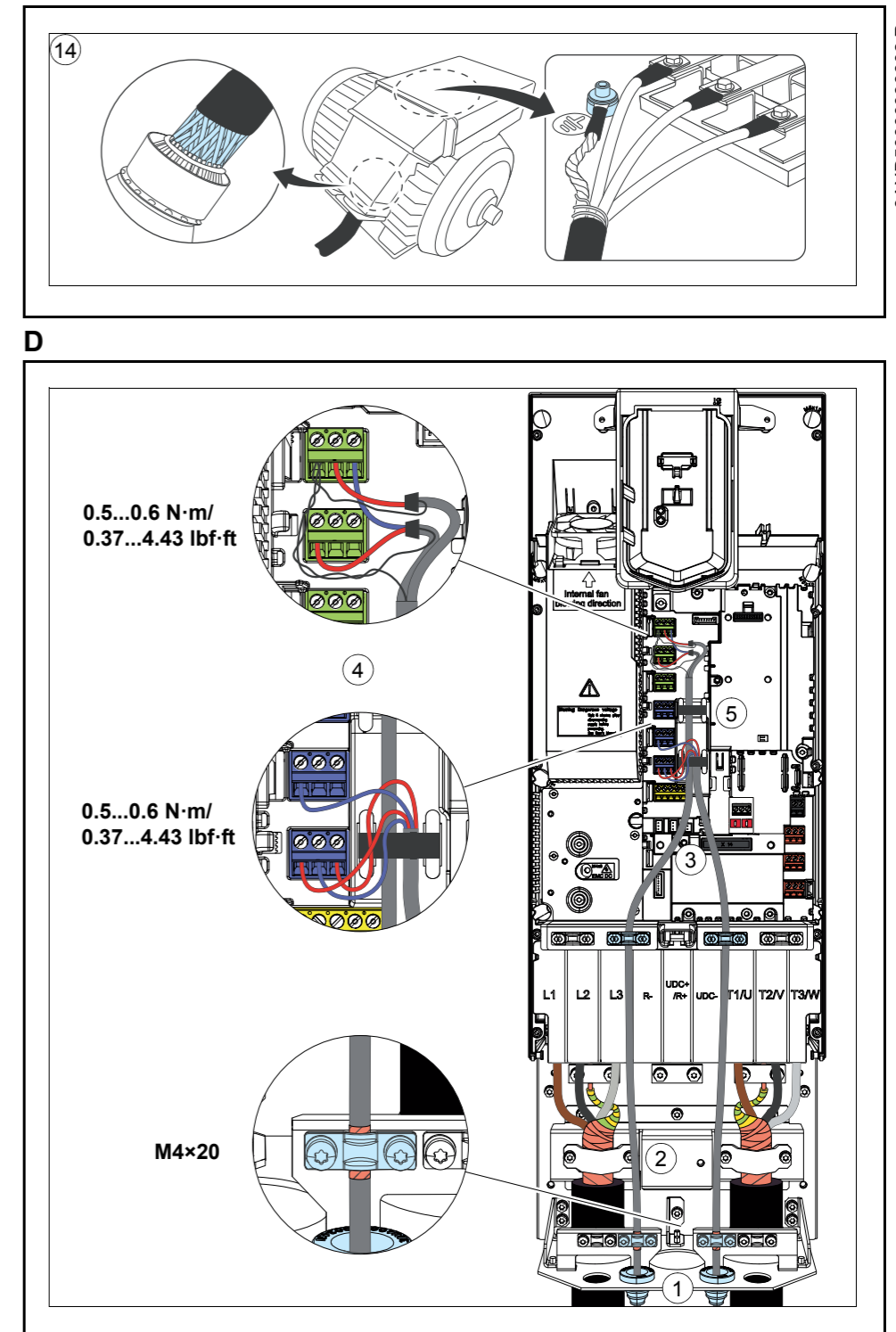
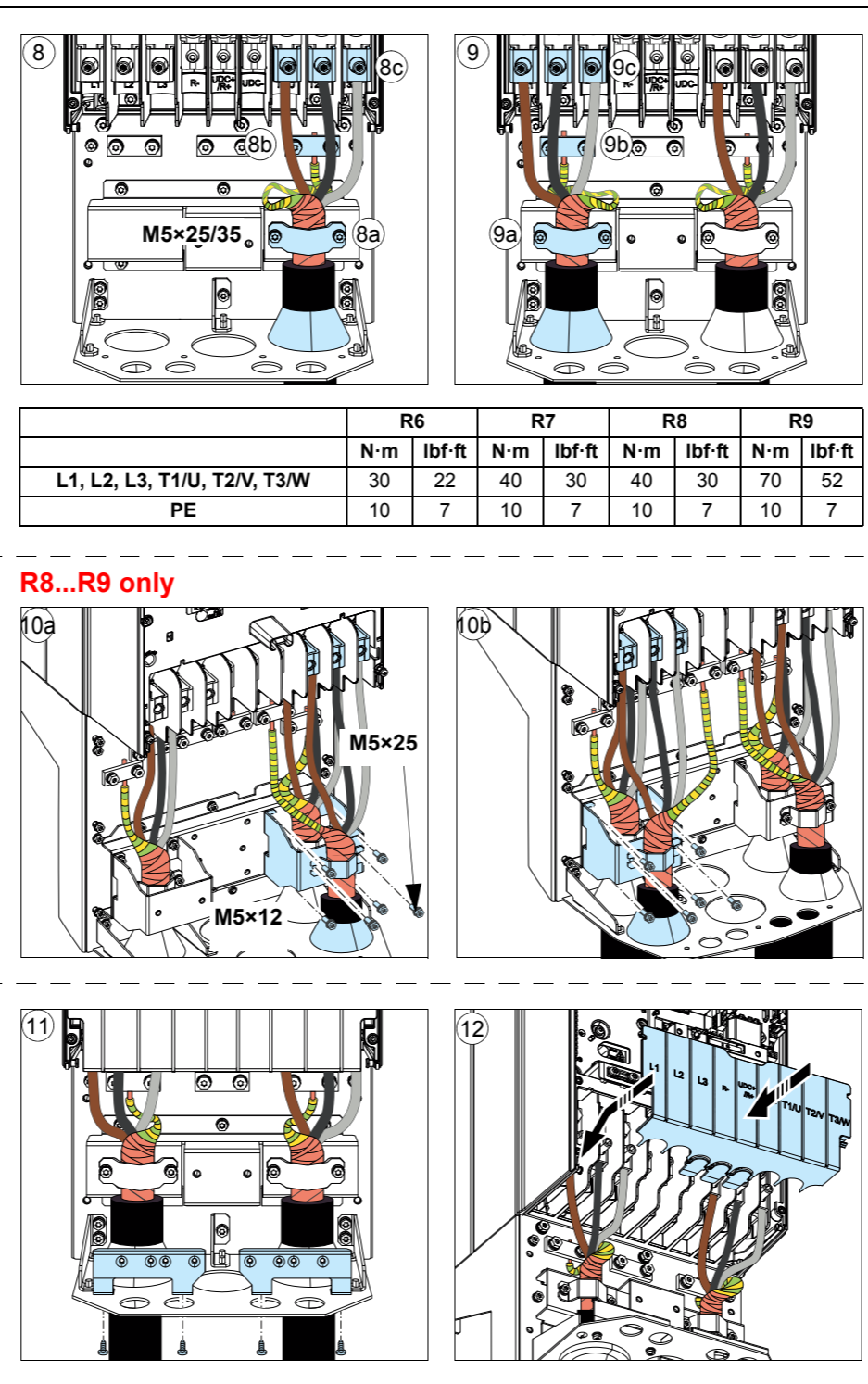
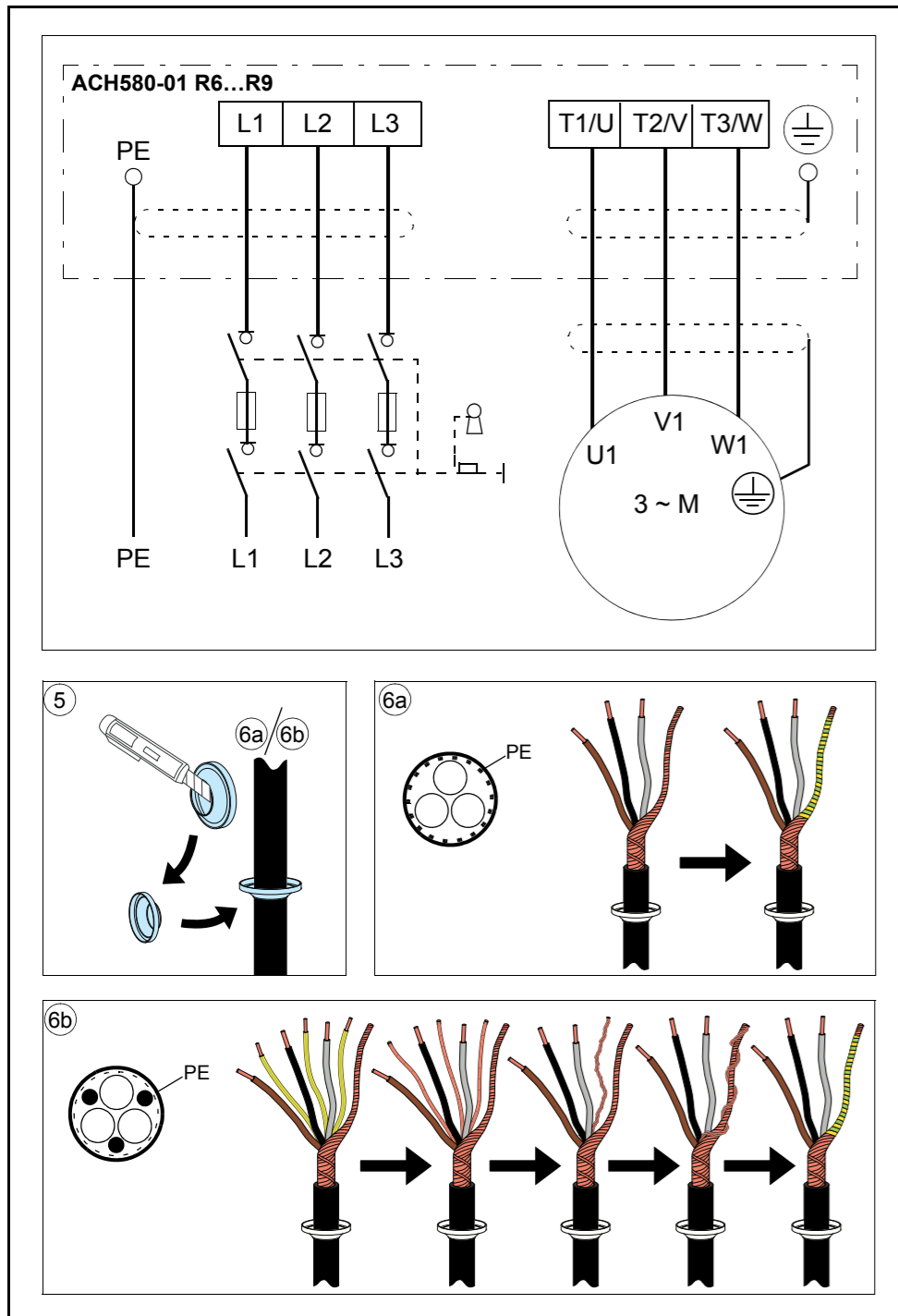

R6...R9 Figures E

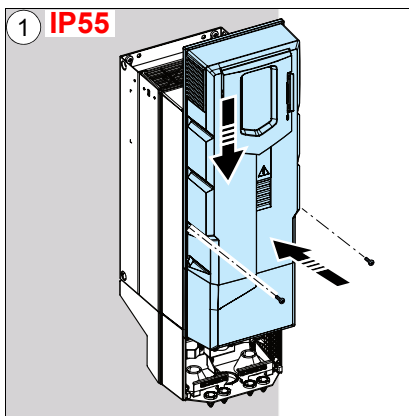
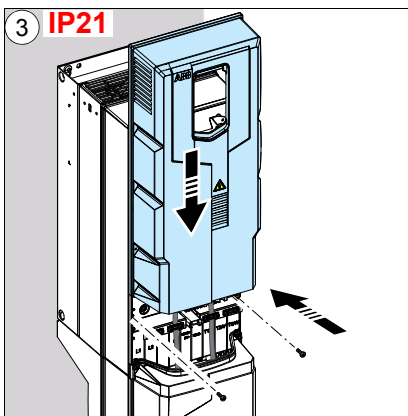
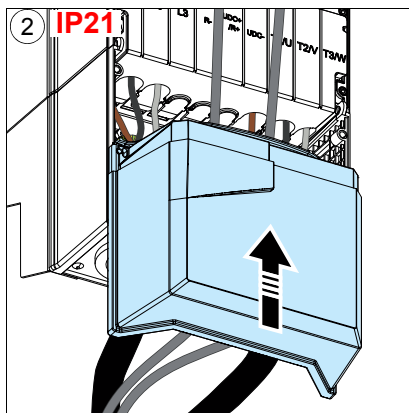
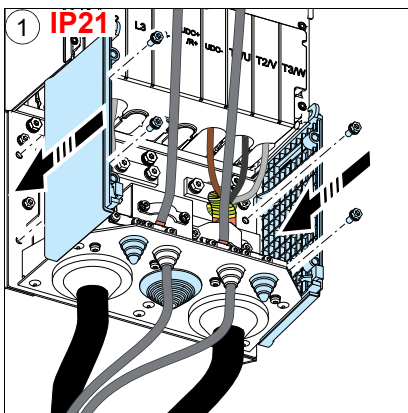

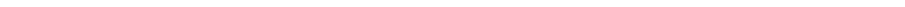

Quick start-up guide ACH580-01 drives Frames R0 to R9

R0-
R9



English	163	EN
Dansk	169	DA
Deutsch	175	DE
Español	181	ES
Suomi	187	FI
Français	193	FR
Italiano	199	IT
Nederlands	205	NL
Polski	211	PL
Português	217	PT
Русский	223	RU
Svenska	229	SV
Türkçe	235	TR
中文	241	ZH

3AXD50000036602 Rev A
MUL
EFFECTIVE: 2016-03-11

EN – Quick start-up guide

This guide describes how to start-up the drive using the First start assistant on the HVAC control panel. For complete information on start-up, see *ACH580 firmware manual* (3AXD50000027537 [English]).









Before you start

Ensure that the drive has been installed as described in chapter [EN – R6...R9 Quick installation guide](#) on page 15 (frames R6...R9).

R0-
R9

Start-up with the First start assistant on an HVAC control panel

EN

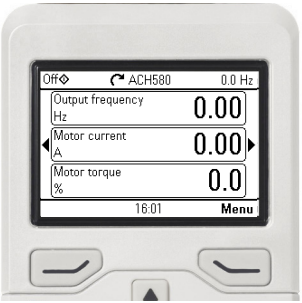
Safety	
<input type="checkbox"/>	Make sure that the installation work is complete. Make sure that cover of the drive and the cable box, if included, are on place.
<input type="checkbox"/>	 Check that the starting of the motor does not cause any danger. De-couple the driven machine if there is a risk of damage in case of an incorrect direction of rotation.
Hints on using the assistant control panel	
<p>The two commands at the bottom of the display (Options and Menu in the figure on the right), show the functions of the two softkeys  and  located below the display. The commands assigned to the softkeys vary depending on the context.</p> <p>Use keys , ,  and  to move the cursor and/or change values depending on the active view.</p> <p>Key  shows a context-sensitive help page.</p>	
1 – First start assistant guided settings: Language, motor nominal values, and date and time	
<input type="checkbox"/>	Have the motor name plate data at hand. Power up the drive.

R0-R9

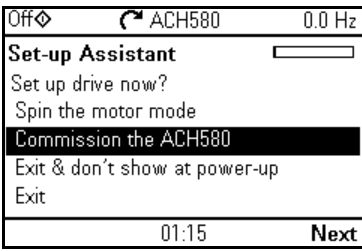

EN

<p><input type="checkbox"/> The First start assistant guides you through the first start-up. The assistant begins automatically. Wait until the control panel enters the view shown on the right. Select the language you want to use by highlighting it (if not already highlighted) and pressing (OK). Note: After you have selected the language, it takes a few minutes for the control panel to wake up.</p>	
<p><input type="checkbox"/> Select Commission the ACH580 and press (Next).</p>	

Refer to the motor nameplate for the following nominal value settings of the motor. Enter the values exactly as shown on the motor nameplate.

Example of a nameplate of an induction (asynchronous) motor:

3 ~ motor M2AA 200 MLA 4									
IEC 200 M/L 55									
No									
Ins.cl.					F IP 55				
V	Hz	kW	r/min	A	cos φ	I _A /I _N	t _E /s		
690 Y	50	30	1475	32.5	0.83				
400 D	50	30	1475	56	0.83				
660 Y	50	30	1470	34	0.83				
380 D	50	30	1470	59	0.83				
415 D	50	30	1475	54	0.83				
440 D	60	35	1770	59	0.83				
Cat. no 3GAA 202 001 - ADA									
6312/C3			6210/C3			180 kg			
IEC 34-1									

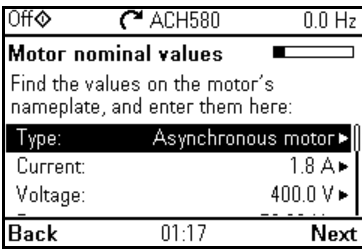













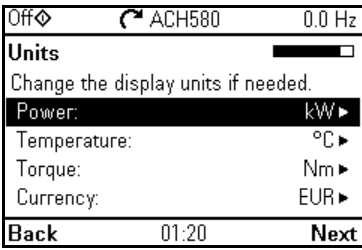

<p><input type="checkbox"/> Check that the motor data is correct. Values are predefined on the basis of the drive size but you should verify that they correspond to the motor. Start with the motor type.</p> <ul style="list-style-type: none"> • Go to the edit view of a selected row by pressing . • Scroll the view with and . <p>Motor nominal cosφ and nominal torque are optional. Press (Next) to continue.</p>	
---	---

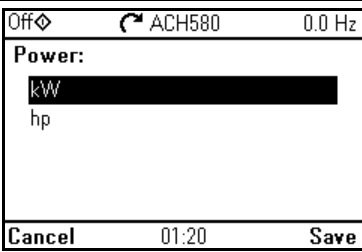
<input type="checkbox"/>	<p>To change a value in an edit view:</p> <ul style="list-style-type: none"> • Use and to move the cursor left and right. • Use and to change the value. <p>Press (Save) to accept the new setting, or press (Cancel) to go back to the previous view without making changes.</p>	
<input type="checkbox"/>	<p>This step is optional, and requires rotating the motor. Do not do this if it could cause any risk, or if the mechanical set-up does not allow it.</p> <p>To do the direction test, select Spin the motor and press (Next).</p>	
<input type="checkbox"/>	<p>Press the Hand key on the panel to start the drive.</p>	
<input type="checkbox"/>	<p>Check the direction of the motor.</p> <p>If it is forward, select Yes, motor is spinning forward and press (Next) to continue.</p> <p>If the direction is not forward, select No, fix direction and press (Next) to continue.</p>	
<input type="checkbox"/>	<p>Select the localization you want to use and press (Next).</p>	

R0-R9

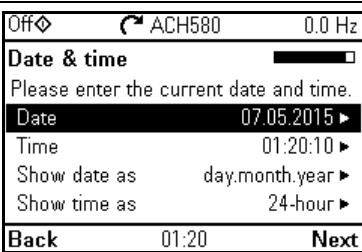

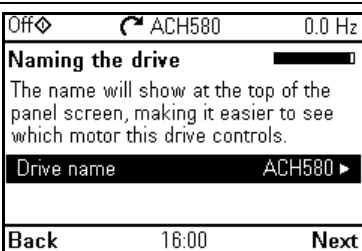
EN

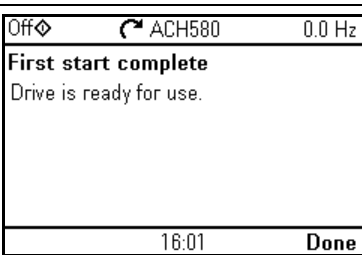
<p><input type="checkbox"/></p>	<p>Change the units shown on the panel if needed.</p> <ul style="list-style-type: none"> Go to the edit view of a selected row by pressing . Scroll the view with  and . <p>Go to the next view by pressing  (Next).</p>	
<p><input type="checkbox"/></p>	<p>To select a value in an edit view:</p> <ul style="list-style-type: none"> Use  and  to select the value. <p>Press  (Save) to accept the new setting, or press  (Cancel) to go back to the previous view without making changes.</p>	
<p><input type="checkbox"/></p>	<p>Set the date and time as well as date and time display formats.</p> <ul style="list-style-type: none"> Go to the edit view of a selected row by pressing . Scroll the view with  and . <p>Go to the next view by pressing  (Next).</p>	
<p><input type="checkbox"/></p>	<p>To give the drive a name that will be shown at the top, press .</p> <p>If you do not want to change the default name (ACH580), continue by pressing  (Next).</p> <p>For information on editing text, see <i>ACH580 firmware manual</i> (3AXD50000027537 [English]).</p>	
<p><input type="checkbox"/></p>	<p>The first start is now complete and the drive is ready for use.</p> <p>Press  (Done) to enter the Home view.</p>	

R0-R9

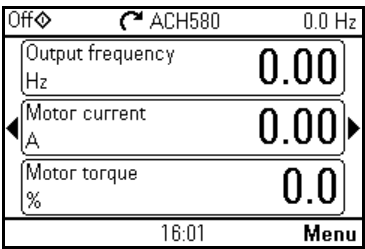

EN

<input type="checkbox"/>	The Home view monitoring the values of the selected signals is shown on the panel.	 <p>Off ◊ ↻ ACH580 0.0 Hz</p> <p>Output frequency 0.00 Hz</p> <p>Motor current 0.00 ◀ A ▶</p> <p>Motor torque 0.0 %</p> <p>16:01 Menu</p>
--------------------------	--	---

R0-
R9

EN

2 – Hand/Off/Auto operation

- The drive can be in remote control or local control, and in local control there are additionally two different modes.

Remote control: Drive is controlled from the I/O or the fieldbus.

- Top row of the view shows Auto.

Local control: Drive is controlled from the control panel.

- Top row of the view shows Off, that is, the drive is in the Off mode. Drive is stopped.
- Top row of the view shows Hand, that is, the drive is in the Hand mode. Drive is running. The initial reference in the Hand mode is copied from the drive reference.

Symbol \blacklozenge on the top row indicates that you can change the reference with \blacktriangle and \blacktriangledown .

The following diagram shows the state transitions when you press the Hand, Off or Auto button:

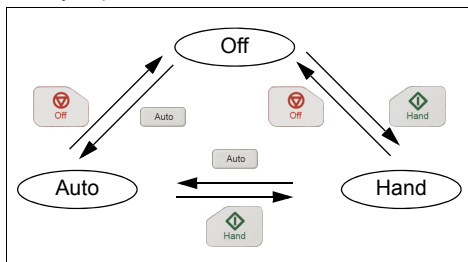

Note: When you restart the drive while fault 7081 Control panel loss is active, the mode changes from Hand or Off to Auto.

Note: Override operation overrides the actual running mode. See *ACH580 firmware manual* (3AXD50000027537 [English]).

Auto	ACH580	30.0 Hz
Output frequency	Hz	30.04
Motor current	A	0.46
Motor torque	%	9.4
		16:00
		Menu

Off	ACH580	0.0 Hz
Output frequency	Hz	0.00
Motor current	A	0.00
Motor torque	%	0.0
		16:01
		Menu

Hand	ACH580	30.0 Hz
Output frequency	Hz	30.00
Motor current	A	0.45
Motor torque	%	9.4
Reference		16:00
		Menu

Off	ACH580	0.0 Hz
Fault 7081		
Aux code: 0000 0000		
Control panel loss		16:18:35
Control panel loss fault		
Hide		16:54
		Reset

R0-R9



EN

DA – Vejledning til hurtig opstart









Denne vejledning beskriver, hvordan du starter frekvensomformerer op ved hjælp af HVAC-betjeningspanelet og Første start-assistenten. Se alle oplysninger om opstart i *ACH580 firmware manual* (3AXD50000027537 [på engelsk]).

Inden du starter

Sørg for, at frekvensomformerer er installeret som beskrevet i kapitlet [DA – R6...R9 Hurtig installationsvejledning](#) på side 25 (modul R6...R9).

R0-
R9

Opstart ved hjælp af HVAC-betjeningspanelet og Første start-assistenten

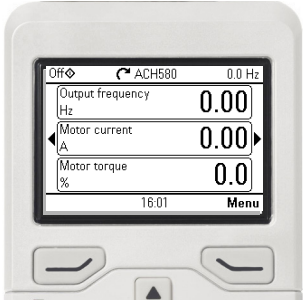











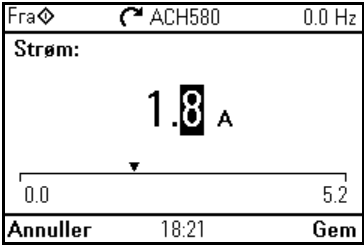

Sikkerhed	
<input type="checkbox"/>	Sørg for, at installationsarbejdet er fuldført. Sørg for, at frekvensomformerens dæksel og kabelboksen, hvis denne findes, er på plads.
<input type="checkbox"/>	 Kontrollér, at start af motoren ikke medfører fare. Frakobl den drevne maskine , hvis der er risiko for ødelæggelse i tilfælde af forkert omløbsretning.
Tips til brug af assistentbetjeningspanelet	
<p>De to kommandoer nederst i displayet (i dette tilfælde Indstillinger og Menu i figuren til højre), viser funktionerne for de to taster  og  nederst i displayet. Tasternes tilknyttede kommandoer varierer alt efter sammenhængen. Brug tasterne , ,  og  til at flytte markøren og/eller at ændre værdier alt efter det aktive vindue. Tasten  viser en kontekstafhængig hjælpeside.</p>	
1 – Indstillinger for Assistent til første start: Sprog, motorens nominelle værdier samt dato og klokkeslæt	
<input type="checkbox"/>	Du skal have dataene fra motormærkepladen til rådighed. Start frekvensomformerer op.

DA

R0-
R9





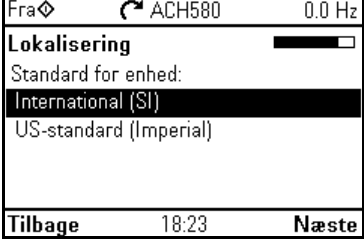









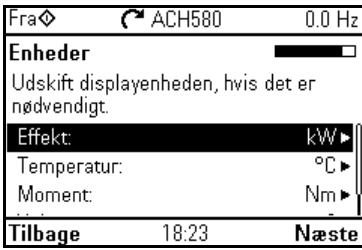

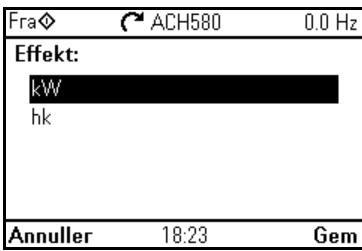

DA

<input type="checkbox"/> Assistenten til første start guider dig gennem den første opstart. Assistenten starter automatisk. Vent indtil betjeningspanelet viser vinduet til højre. Vælg det sprog, du ønsker at benytte ved at fremhæve det (hvis det ikke allerede er fremhævet), og tryk derefter på (OK). Bemærk! Når du har valgt sprog, tager det nogle minutter, før betjeningspanelet vågner.																																																									
<input type="checkbox"/> Vælg Idræftsæt ACH580 , og tryk på (Næste).																																																									
Se motorens mærkeplade for oplysninger om de følgende indstillinger af motorens nominelle værdier. Indtast værdierne <u>nøjagtigt</u> som de er angivet på motormærkepladen.																																																									
Eksempel på en mærkeplade fra en (asynkron) induktionsmotor:																																																									
<p>ABB Motors </p> <p>3 ~ motor M2AA 200 MLA 4 IEC 200 M/L 55</p> <p>Ins.cl. F IP 55</p> <table border="1"> <thead> <tr> <th>V</th> <th>Hz</th> <th>kW</th> <th>r/min</th> <th>A</th> <th>cos φ</th> <th>IA/IN</th> <th>tE/s</th> </tr> </thead> <tbody> <tr> <td>690 Y</td> <td>50</td> <td>30</td> <td>1475</td> <td>32.5</td> <td>0.83</td> <td></td> <td></td> </tr> <tr> <td>400 D</td> <td>50</td> <td>30</td> <td>1475</td> <td>56</td> <td>0.83</td> <td></td> <td></td> </tr> <tr> <td>660 Y</td> <td>50</td> <td>30</td> <td>1470</td> <td>34</td> <td>0.83</td> <td></td> <td></td> </tr> <tr> <td>380 D</td> <td>50</td> <td>30</td> <td>1470</td> <td>59</td> <td>0.83</td> <td></td> <td></td> </tr> <tr> <td>415 D</td> <td>50</td> <td>30</td> <td>1475</td> <td>54</td> <td>0.83</td> <td></td> <td></td> </tr> <tr> <td>440 D</td> <td>60</td> <td>35</td> <td>1770</td> <td>59</td> <td>0.83</td> <td></td> <td></td> </tr> </tbody> </table> <p>Cat. no 3GAA 202 001 - ADA</p> <p>6312/C3 6210/C3 180 kg</p> <p>IEC 34-1</p>		V	Hz	kW	r/min	A	cos φ	IA/IN	tE/s	690 Y	50	30	1475	32.5	0.83			400 D	50	30	1475	56	0.83			660 Y	50	30	1470	34	0.83			380 D	50	30	1470	59	0.83			415 D	50	30	1475	54	0.83			440 D	60	35	1770	59	0.83		
V	Hz	kW	r/min	A	cos φ	IA/IN	tE/s																																																		
690 Y	50	30	1475	32.5	0.83																																																				
400 D	50	30	1475	56	0.83																																																				
660 Y	50	30	1470	34	0.83																																																				
380 D	50	30	1470	59	0.83																																																				
415 D	50	30	1475	54	0.83																																																				
440 D	60	35	1770	59	0.83																																																				
<input type="checkbox"/> Kontrollér, at motordata er korrekte. Værdierne er foruddefinerede ud fra frekvensomformerens størrelse, men du skal verificere, at de svarer til motoren. Start med motortypen. <ul style="list-style-type: none"> • Flyt markøren til redigeringsvinduet for den ønskede række ved at trykke på . • Rul frem til vinduet ved hjælp af og . Motorens nominelle cosφ og det nominelle moment er valgfrie. Tryk på (Næste) for at fortsætte.																																																									

<input type="checkbox"/> <p>Sådan ændrer du en værdi i et redigeringsvindue:</p> <ul style="list-style-type: none"> • Brug  og  til at flytte markøren til venstre eller højre. • Brug  og  til at ændre værdien. <p>Tryk på  (Gem) for at acceptere de nye indstillinger, eller tryk på  (Annuller) for at returnere til det forrige vindue uden at foretage nogen ændringer.</p>	
<input type="checkbox"/> <p>Dette trin er valgfrit og kræver, at motoren roterer. Undlad denne, hvis der er nogen som helst risiko, eller hvis den mekaniske opsætning ikke tillader det.</p> <p>For at udføre retningstesten, skal du vælge Roter motoren, og derefter trykke på  (Næste).</p>	
<input type="checkbox"/> <p>Tryk på tasten Hand  på betjeningspanelet for at starte frekvensomformereren.</p>	
<input type="checkbox"/> <p>Kontrollér motorens retning.</p> <p>Hvis den kører forlæns, skal du vælge Ja, motor roterer fremad, og derefter trykke på  (Næste) for at fortsætte.</p> <p>Hvis den ikke kører fremad, skal du vælge Nej, skift retning, og derefter trykke på  (Næste) for at fortsætte.</p>	
<input type="checkbox"/> <p>Vælg den lokalisering, du vil benytte, og tryk på  (Næste).</p>	

 R0-
R9

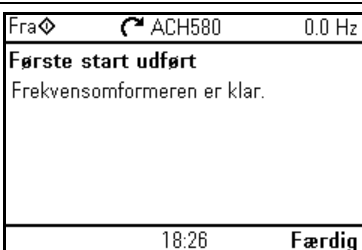

DA

<input type="checkbox"/>	<p>Vælg eventuelt hvilke enheder, der skal benyttes i betjeningspanelet.</p> <ul style="list-style-type: none"> Flyt markøren til redigeringsvinduet for den ønskede række ved at trykke på . Rul frem til vinduet ved hjælp af  og . <p>Gå til det næste vindue ved at trykke på  (Næste).</p>	
<input type="checkbox"/>	<p>Sådan vælger du en værdi i et redigeringsvindue:</p> <ul style="list-style-type: none"> Brug  og  til at vælge en værdi. <p>Tryk på  (Gem) for at acceptere de nye indstillinger, eller tryk på  (Annuller) for at returnere til det forrige vindue uden at foretage nogen ændringer.</p>	
<input type="checkbox"/>	<p>Indstil dato og klokkeslæt samt visningsformat for dato og klokkeslæt.</p> <ul style="list-style-type: none"> Flyt markøren til redigeringsvinduet for den ønskede række ved at trykke på . Rul frem til vinduet ved hjælp af  og . <p>Gå til det næste vindue ved at trykke på  (Næste).</p>	
<input type="checkbox"/>	<p>Hvis du vil navngive frekvensomformereren, så navnet vises øverst, skal du trykke på .</p> <p>Hvis du vil ændre standardnavnet (ACH580), skal du fortsætte ved at trykke på  (Næste).</p> <p>Oplysninger om redigering af tekst findes i <i>ACH580 firmware manual</i> (3AXD50000027537 (på engelsk)).</p>	
<input type="checkbox"/>	<p>Den første start er nu færdig, og frekvensomformereren er klar til brug.</p> <p>Tryk på  (Færdig) for at returnere til startside.</p>	

R0-R9

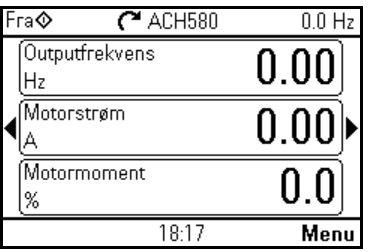

DA

<input type="checkbox"/>	På startside overvåges værdierne for de valgte værdier, og disse vises i panelet.	 <table border="1"><tr><td>Fra</td><td>ACH580</td><td>0.0 Hz</td></tr><tr><td>Outputfrekvens Hz</td><td></td><td>0.00</td></tr><tr><td>Motorstrøm A</td><td></td><td>0.00</td></tr><tr><td>Motormoment %</td><td></td><td>0.0</td></tr><tr><td colspan="2"></td><td>18:17</td></tr><tr><td colspan="2"></td><td>Menu</td></tr></table>	Fra	ACH580	0.0 Hz	Outputfrekvens Hz		0.00	Motorstrøm A		0.00	Motormoment %		0.0			18:17			Menu
Fra	ACH580	0.0 Hz																		
Outputfrekvens Hz		0.00																		
Motorstrøm A		0.00																		
Motormoment %		0.0																		
		18:17																		
		Menu																		

R0-
R9

DA

2 – Hånd/Fra/Autodrift

- Frekvensomformereren kan fjernstyres eller lokalstyres, og lokalstyring omfatter to forskellige tilstande.

Fjernstyring: Frekvensomformereren styres fra I/O eller fieldbus.

- Øverst række i vinduet ses Auto.

Lokalstyring: Frekvensomformereren styres fra betjeningspanelet.

- Øverst række i vinduet viser Fra, dvs. frekvensomformereren er i tilstanden Fra. Frekvensomformereren er stoppet.
- Øverste række i vinduet viser Hånd, dvs. frekvensomformereren er i tilstanden Hånd. Frekvensomformereren i drift. Den indledende reference i tilstanden Hånd kopieres fra frekvensomformererreferencen.

Symbolet \updownarrow i øverste række angiver, at du kan ændre referencen med \uparrow og \downarrow .

Følgende diagram viser statustransitionerne, når du trykker på knappen Hand, Off eller Auto:

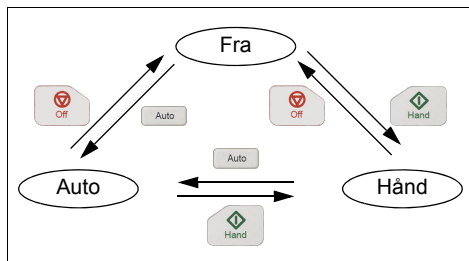

Bemærk! Når du genstarter frekvensomformereren, mens fejl 7081 for mistet panelstyring er aktiv, skifter tilstanden fra Hånd eller Fra til Auto.

Bemærk! Tilsidesæt drift tilsidesætter den aktuelle driftstilstand. Se *ACH580 firmware manual* (3AXD50000027537 (på engelsk)).

Auto	ACH580	29.6 Hz
Outputfrekvens Hz	29.50	
Motorstrøm A	0.95	
Motormoment %	46.8	
18:27		Menu

Fra	ACH580	0.0 Hz
Outputfrekvens Hz	0.00	
Motorstrøm A	0.00	
Motormoment %	0.0	
18:17		Menu

Hånd	ACH580	30.0 Hz
Outputfrekvens Hz	30.00	
Motorstrøm A	0.95	
Motormoment %	46.2	
Reference	18:28	Menu

Fra	ACH580	30.0 Hz
Fejl 7081		
AUX-kode: 0000 0000		
Betjeningspanelfejl	18:28:20	
Fejl i betjeningspanel		
Skjul	18:28	Nulstil

R0-R9



DA

DE – Kurzanleitung für die Inbetriebnahme

Diese Anleitung beschreibt die Erstinbetriebnahme des Frequenzumrichters mit dem Inbetriebnahme-Assistenten des HLK-Bedienpanels. Die vollständigen Informationen für die Inbetriebnahme enthält das *Firmware-Handbuch ACH580 HLK-Regelungsprogramm* (3AXD50000027591 [deutsch]).









R0-
R9

Vor Beginn der Arbeit

Stellen Sie sicher, dass der Frequenzumrichter entsprechend der Beschreibung in Kapitel *DE – R6...R9 Kurzanleitung für die Installation* auf Seite 35 (Baugrößen R6...R9) installiert wurde.

Erstinbetriebnahme mit dem Assistenten des HLK- Bedienpanels

DE

Sicherheit	
<input type="checkbox"/>	Stellen Sie sicher, dass die Installationsarbeiten abgeschlossen sind. Stellen Sie sicher, dass die Abdeckungen des Frequenzumrichters und des Kabelanschlusskastens, falls vorhanden, montiert sind.
<input type="checkbox"/>	 Prüfen Sie, dass durch den Start des Motors keine Gefährdungen entstehen. Kopeln Sie die angetriebene Maschine ab , wenn durch eine falsche Drehrichtung eine Gefährdung entsteht.
Hinweise zur Verwendung des Komfort-Bedienpanels	
<p>Die zwei Befehlsanzeigen am unteren Rand des Displays (in dem Bild rechts Optionen und Menü), zeigen die Funktionen der zwei Funktionstasten  und  an, die sich unter dem Display befinden. Die den Funktionstasten zugeordneten Befehlsanzeigen sind vom Betriebszustand abhängig.</p> <p>Mit den Tasten , ,  und  können Sie, je nach aktiver Ansicht, den Cursor bewegen und/oder Werte ändern.</p> <p>Taste  zeigt eine kontextsensitive Hilfe-Seite an.</p>	
1 – Erste Inbetriebnahme mit dem Assistenten, Grundeinstellungen: Sprache, Motor-Nenndaten, Datum und Uhrzeit	
<input type="checkbox"/>	<p>Zur Einstellung müssen die Daten vom Motortypenschild verfügbar sein.</p> <p>Den Frequenzumrichter einschalten.</p>

R0-R9



- Der Inbetriebnahme-Assistent führt Sie durch die erste Inbetriebnahme.
 Der Assistent startet automatisch. Warten Sie, bis das Bedienpanel die erste Ansicht, wie rechts dargestellt, anzeigt.
 Auswahl der Sprache, die benutzt werden soll, durch Markieren dieser Sprache (falls nicht bereits markiert) und (**OK**) drücken.
Hinweis: Nach Auswahl der Sprache dauert es einige Zeit, bis die Umstellung des Bedienpanels erfolgt ist.
- Wählen Sie **Inbetriebnahme des ACH580** und drücken Sie dann Taste (**Weiter**).

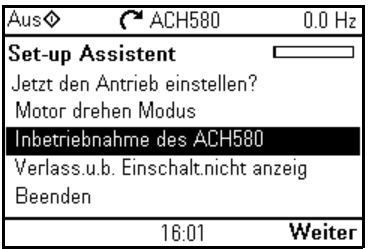















DE

Für die folgenden Einstellungen der Motordaten die Nenndaten die Nenndaten vom Motor-Typenschild verwenden. Die auf dem Motor-Typenschild angegebenen Werte genau eingeben.

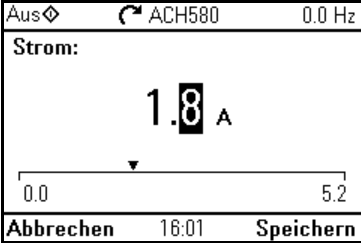
Beispiel für ein Typenschild eines Asynchronmotors:

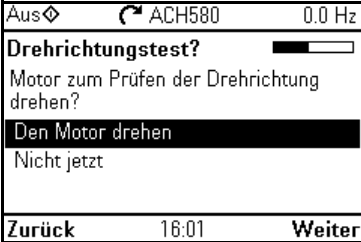
<div style="display: flex; justify-content: space-between; align-items: center;"> ABB Motors </div>										
3 ~ motor		M2AA 200 MLA 4								
IEC 200 M/L 55										
No										
Ins.cl. F					IP 55					
V	Hz	kW	r/min	A	cos φ	IA/IN	tE/s			
690 Y	50	30	1475	32.5	0.83					
400 D	50	30	1475	56	0.83					
660 Y	50	30	1470	34	0.83					
380 D	50	30	1470	59	0.83					
415 D	50	30	1475	54	0.83					
440 D	60	35	1770	59	0.83					
Cat. no 3GAA 202 001 - ADA										
6312/C3						6210/C3			180 kg	
IEC 34-1										















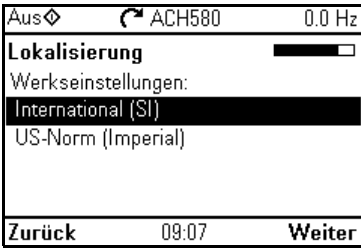

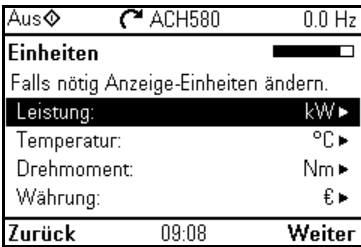

<p><input type="checkbox"/> Prüfen Sie, ob die Motordaten korrekt eingegeben wurden. Die Werte sind auf Basis der Frequenzumrichtergröße voreingestellt und Sie müssen sicherstellen, dass sie mit den Daten auf dem Motor-Typenschild übereinstimmen.</p> <p>Starten mit dem Motortyp.</p> <ul style="list-style-type: none"> • Durch Drücken von  zur Bearbeitungssicht einer ausgewählten Zeile wechseln. • Blättern durch die Ansicht mit den Tasten  und . <p>Motornenn-cosϕ und Motornennmoment sind optional.</p> <p>Mit der Taste  (Weiter) fortfahren.</p>	
<p><input type="checkbox"/> Ändern eines Werts in der Ansicht Bearbeiten:</p> <ul style="list-style-type: none"> • Mit den Tasten  und  den Cursor nach links und rechts bewegen. • Mit den Tasten  und  den Einstellwert ändern. <p>Mit der Taste  (Speichern) die neue Einstellung übernehmen, oder mit Taste  (Abbrechen) ohne Änderungen zur vorhergehenden Ansicht zurückkehren.</p>	
<p><input type="checkbox"/> Dieser Schritt ist optional und dafür muss der Motor drehen. Diesen Schritt nicht durchführen, wenn dadurch ein Risiko verursacht wird oder dieser Schritt aufgrund der mechanischen Einrichtung nicht möglich ist.</p> <p>Für einen Drehrichtungstest die Zeile Den Motor drehen markieren und die Taste  (Weiter) drücken.</p>	
<p><input type="checkbox"/> Mit Drücken der Taste  auf dem Bedienpanel den Antrieb starten.</p>	





R0-
R9

DE

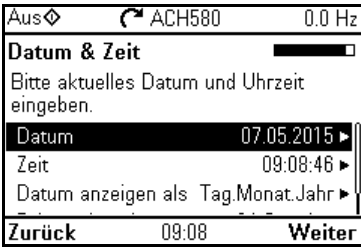
R0-
R9

DE

<input type="checkbox"/>	<p>Prüfen Sie die Drehrichtung des Motors. Bei Drehrichtung vorwärts, Ja, Motor dreht vorwärts markieren und die Taste  (Weiter) drücken, um fortzufahren. Ist die Drehrichtung nicht vorwärts, Nein, Drehrichtung ändern markieren und die Taste  (Weiter) drücken, um fortzufahren.</p>	
<input type="checkbox"/>	<p>Die gewünschte Lokalisierung auswählen und Taste  (Weiter) drücken.</p>	
<input type="checkbox"/>	<p>Die auf dem Panel angezeigten Einheiten ändern, falls erforderlich.</p> <ul style="list-style-type: none"> Durch Drücken von  zur Bearbeitungssicht einer ausgewählten Zeile wechseln. Blättern durch die Ansicht mit den Tasten  und . <p>Gehen Sie mit Taste  (Weiter) zur nächsten Ansicht.</p>	
<input type="checkbox"/>	<p>Auswählen eines Werts in der Ansicht Bearbeiten (Edit):</p> <ul style="list-style-type: none"> Mit  und  den gewünschten Wert auswählen. <p>Mit der Taste  (Speichern) die neue Einstellung übernehmen, oder mit Taste  (Abbrechen) ohne Änderungen zur vorhergehenden Ansicht zurückkehren.</p>	
<input type="checkbox"/>	<p>Datum und Uhrzeit sowie das Anzeigeformat von Datum und Uhrzeit einstellen.</p> <ul style="list-style-type: none"> Durch Drücken von  zur Bearbeitungssicht einer ausgewählten Zeile wechseln. Blättern durch die Ansicht mit den Tasten  und . <p>Gehen Sie mit Taste  (Weiter) zur nächsten Ansicht.</p>	

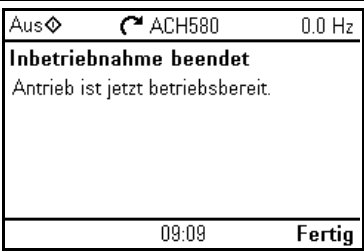
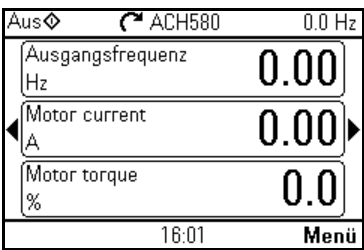
<input type="checkbox"/>	<p>Um dem Frequenzumrichter einen Namen zu geben, der in der Kopfzeile angezeigt wird, die Taste  drücken.</p> <p>Wenn Sie den Standard-Namen (ACH580) ändern möchten, fahren Sie fort mit Taste  (Weiter).</p> <p>Informationen zum Bearbeiten von Text enthält das Handbuch <i>ACH580 firmware manual</i> (3AXD50000027537 [englisch]).</p>	
<input type="checkbox"/>	<p>Die Erstinbetriebnahme ist nun komplett und der Frequenzumrichter betriebsbereit.</p> <p>Die Taste  (Fertig) drücken, um zur Startansicht zu gelangen.</p>	
<input type="checkbox"/>	<p>Mit der Startansicht können die Werte der ausgewählten Signale auf dem Bedienpanel angezeigt werden.</p>	

R0-R9



DE

2 – Betriebsart Hand/Off/Auto

Der Frequenzumrichter hat die Betriebsarten Fernsteuerung oder Lokalsteuerung, und in der Lokalsteuerung gibt es zusätzlich zwei verschiedene Steuerungsarten.

Fernsteuerung: Der Antrieb wird über E/A des Frequenzumrichters oder einen Feldbus gesteuert.

- In der oberen Zeile der Bedienpanelanzeige wird Auto angezeigt.

Lokalsteuerung: Der Antrieb wird mit dem Bedienpanel gesteuert:

- In der oberen Zeile der Bedienpanelanzeige wird Off/Aus angezeigt, d.h. der Frequenzumrichter ist im Modus Off/Aus. Der Antrieb ist gestoppt.
- In der oberen Zeile der Bedienpanelanzeige wird Hand angezeigt, d.h. der Frequenzumrichter ist im Modus Hand. Der Antrieb Antriebläuft. Der Anfangs-Sollwert im Modus Hand wird vom Antriebsollwert des Frequenzumrichters kopiert. Das Symbol \blacklozenge in der oberen Zeile zeigt an, dass der Sollwert mit \blacktriangleup und \blacktriangledown geändert werden kann.

Das folgende Diagramm zeigt die Statuswechsel beim Drücken der Taste Hand, Off oder Auto:

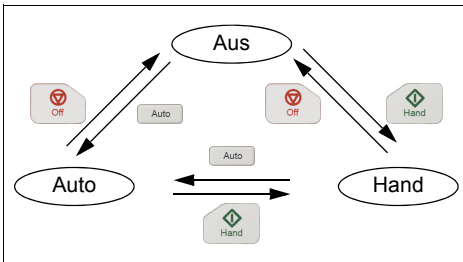

Hinweis: Bei einem Neustart des Frequenzumrichters während die Störung 7081, aktive Bedienpanel-Störung, ansteht, wechselt der Modus von Hand oder Off/Aus auf Auto.

Hinweis: Der Override-Betrieb hat Vorrang vor dem aktuellen Betriebsmodus. Siehe *Firmware-Handbuch ACH580 HLK-Regelungsprogramm* (3AXD50000027591 [deutsch]).

Auto	ACH580	30.0 Hz
Ausgangsfrequenz		30.04
Hz		
Motor current	0.46	▶
A		
Motor torque	9.4	
%		
16:00		Menü

Aus \blacklozenge	ACH580	0.0 Hz
Ausgangsfrequenz		0.00
Hz		
Motor current	0.00	▶
A		
Motor torque	0.0	
%		
16:01		Menü

Hand \blacklozenge	ACH580	\blacktriangleup 30.0 Hz
Ausgangsfrequenz		30.00
Hz		
Motor current	0.45	▶
A		
Motor torque	9.4	
%		
Sollwert 16:00		Menü

Aus \blacklozenge	ACH580	0.0 Hz
✘ Fehler 7081		
Hilfscode: 0000 0000		
Panel-Kommunik.		09:50:42
Panel-Kommunikations-Störung		
Ausblenden 09:50		Quittieren

R0-R9



DE









ES – Guía rápida de puesta en marcha

Esta guía describe la puesta en marcha del convertidor usando el Asistente de primera puesta en marcha en el panel de control HVAC. Consulte la documentación completa sobre la puesta en marcha en el *ACH580 firmware manual* (3AXD50000027537 [Inglés]).

Antes de empezar

Asegúrese de que el convertidor ha sido instalado tal y como se describe en el capítulo *ES – Guía rápida de instalación para bastidores R6...R9* en la página 45 (bastidores R6...R9).

Puesta en marcha con el Asistente de primera puesta en marcha con un panel de control HVAC

Seguridad	
<input type="checkbox"/>	Asegúrese de que se hayan completado las tareas de instalación. Asegúrese de que se hayan colocado la cubierta del convertidor y la caja de entrada de cables, si está incluida.
<input type="checkbox"/>	 Compruebe que la puesta en marcha del motor no entrañe ningún peligro. Desactive la maquinaria accionada si existe riesgo de daños en caso de que la dirección de giro sea incorrecta.
Sugerencias al usar el panel de control asistente	
<p>Los dos comandos de la parte inferior de la pantalla (Opciones y Menú en la imagen de la derecha) muestran las funciones de los dos botones multifunción  y  situados debajo de la pantalla. Los comandos asignados a los botones multifunción varían en función del contexto.</p> <p>Use los botones , ,  y  para mover el cursor y cambiar los valores en función de la vista activa.</p> <p>El botón  muestra una página de ayuda que depende del contexto.</p>	
1 – Asistente de primera puesta en marcha, ajustes guiados: Idioma, valores nominales del motor, y fecha y hora	
<input type="checkbox"/>	Tenga a mano la información de la placa de características del motor. Conecte el convertidor.

R0-
R9

ES

R0-
R9















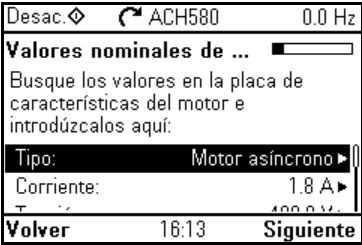

<p><input type="checkbox"/> El Asistente de primera puesta en marcha le guiará durante la misma.</p> <p>El asistente se inicia automáticamente. Espere hasta que en el panel de control aparezca la pantalla de la derecha.</p> <p>Para seleccionar el idioma que desea utilizar, resáltelo (si no lo está ya) y pulse (OK).</p> <p>Nota: Después de haber seleccionado el idioma, el panel de control tarda unos minutos en reactivarse.</p>	
<p><input type="checkbox"/> Seleccione Poner en marcha el ACH580 y pulse (Siguiente).</p>	

ES

Consulte la placa de características del motor para conocer los siguientes valores nominales del motor. Introduzca exactamente los valores que se muestran en la placa de características del motor.

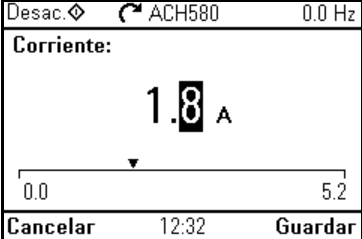
Ejemplo de placa de características de un motor de inducción (asíncrono):

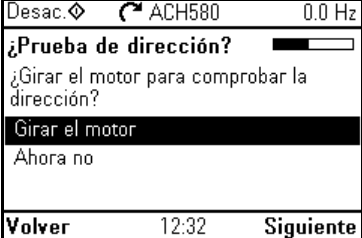
ABB Motors									
3 ~ motor M2AA 200 MLA 4									
IEC 200 M/L 55									
No									
Ins.cl. F					IP 55				
V	Hz	kW	r/min	A	cos φ	IA/IN	tE/s		
690 Y	50	30	1475	32.5	0.83				
400 D	50	30	1475	56	0.83				
660 Y	50	30	1470	34	0.83				
380 D	50	30	1470	59	0.83				
415 D	50	30	1475	54	0.83				
440 D	60	35	1770	59	0.83				
Cat. no 3GAA 202 001 - ADA									
6312/C3			6210/C3			180 kg			
IEC 34-1									

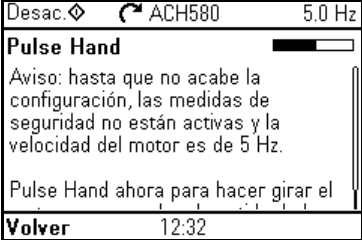
<p><input type="checkbox"/> Compruebe que los datos del motor sean correctos. Los valores están predefinidos según el tamaño del convertidor pero usted debe verificar que se corresponden con los del motor.</p> <p>Empiece por el tipo de motor.</p> <ul style="list-style-type: none"> • Pulse  para ir a la vista de edición de la fila seleccionada. • Desplace la información de la pantalla con los botones  y . <p>Los valores nominales de coseno Φ y de par son opcionales.</p> <p>Pulse  (Siguiente) para continuar.</p>	
<p><input type="checkbox"/> Para modificar un valor en una vista de edición:</p> <ul style="list-style-type: none"> • Use  y  para mover el cursor hacia la izquierda y la derecha. • Use  y  para cambiar el valor. <p>Pulse  (Guardar) para aceptar el nuevo ajuste o pulse  (Cancelar) para volver a la vista anterior sin hacer cambios.</p>	
<p><input type="checkbox"/> Este paso es opcional, y requiere hacer girar el motor. No lo realice si puede entrañar algún riesgo, o si la configuración mecánica no lo permite.</p> <p>Para hacer la prueba de dirección, seleccione Girar el motor y pulse  (Siguiente).</p>	
<p><input type="checkbox"/> Para poner en marcha el convertidor, pulse el botón Hand  en el panel.</p>	

R0-R9







ES

R0-R9



ES

<p><input type="checkbox"/> Compruebe la dirección de giro del motor. Si gira hacia adelante, seleccione Sí, el motor gira hacia adelante y pulse (Siguiente) para continuar. Si no, seleccione No, cambiar dirección y pulse (Siguiente) para continuar.</p>	
<p><input type="checkbox"/> Seleccione el sistema de medidas que desea utilizar y pulse (Siguiente).</p>	
<p><input type="checkbox"/> Si es necesario, modifique las unidades mostradas en el panel.</p> <ul style="list-style-type: none"> • Pulse para ir a la vista de edición de la fila seleccionada. • Desplace la información de la pantalla con los botones y . <p>Pulse (Siguiente) para pasar a la siguiente vista.</p>	
<p><input type="checkbox"/> Para seleccionar un valor en una vista de edición:</p> <ul style="list-style-type: none"> • Use y para seleccionar el valor. <p>Pulse (Guardar) para aceptar el nuevo ajuste o pulse (Cancelar) para volver a la vista anterior sin hacer cambios.</p>	
<p><input type="checkbox"/> Establezca la fecha y la hora, así como su formato.</p> <ul style="list-style-type: none"> • Pulse para ir a la vista de edición de la fila seleccionada. • Desplace la información de la pantalla con los botones y . <p>Pulse (Siguiente) para pasar a la siguiente vista.</p>	

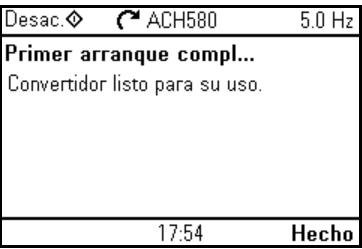
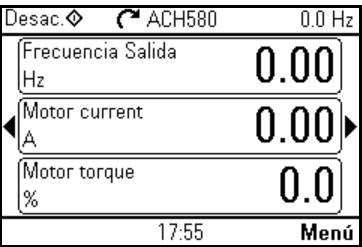
<input type="checkbox"/>	<p>Para darle al convertidor un nombre que aparecerá en la parte superior, pulse .</p> <p>Si no desea cambiar el nombre predeterminado (ACH580), continúe pulsando  (Siguiente).</p> <p>Para obtener información sobre edición de texto, consulte el <i>ACH580 firmware manual</i> (3AXD50000027537 [Inglés]).</p>	
<input type="checkbox"/>	<p>La primera puesta en marcha ha terminado y el convertidor está listo para su uso.</p> <p>Pulse  (Hecho) para ir a la Vista de Inicio.</p>	
<input type="checkbox"/>	<p>En el panel se muestra la Vista de Inicio con la monitorización de los valores de las señales seleccionadas.</p>	

R0-R9



ES

2 – Funcionamiento de Hand/Off/Auto

□ El convertidor puede estar en modo de control remoto o local, y en el modo local dispone de dos modos diferentes adicionales.

Control remoto: El convertidor se controla desde las E/S o el bus de campo.

- La fila superior de la pantalla muestra Auto.

Control local: El convertidor se controla desde el panel de control.

- La fila superior de la pantalla muestra Desac., es decir, el convertidor se encuentra en modo desconectado. El convertidor está parado.
- La fila superior de la pantalla muestra Manu., es decir, el convertidor se encuentra en modo manual. El convertidor está en marcha. La referencia inicial del modo manual se copia de la referencia del convertidor.

El símbolo \blacklozenge en la fila superior indica que es posible modificar la referencia con \blacktriangle y \blacktriangledown .

El siguiente diagrama muestra las transiciones de estado al pulsar los botones Hand, Off o Auto:

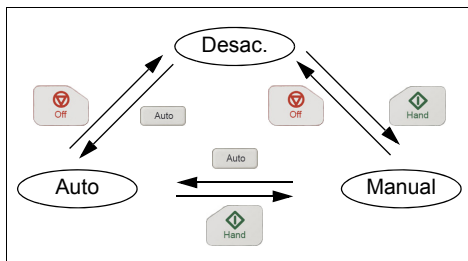

Nota: Al reiniciar el convertidor mientras el fallo 7081 Control panel loss está activo, el modo cambia de Manual u Desactivado a Auto.

Nota: La función Anulación invalida el modo de funcionamiento actual. Véase *ACH580 firmware manual* (3AXD50000027537 [Inglés]).

Auto	ACH580	30.0 Hz
Frecuencia Salida	Hz	30.04
Motor current	A	0.46
Motor torque	%	9.4
		18:09
		Menú

Desac. \blacklozenge	ACH580	0.0 Hz
Frecuencia Salida	Hz	0.00
Motor current	A	0.00
Motor torque	%	0.0
		17:55
		Menú

Manu. \blacklozenge	ACH580	↕ 30.0 Hz
Frecuencia Salida	Hz	30.00
Motor current	A	0.45
Motor torque	%	9.4
Referencia	17:56	Menú

Desac. \blacklozenge	ACH580	0.0 Hz
Fallo 7081		
Código AUX: 0000 0000		
Pérdida panel control	17:55:42	
Fallo de pérdida del panel de control		
Ocultar	17:55	Restaurar

R0-R9



ES

FI – Pika-aloitusopas









Tässä oppaassa kuvataan, miten taajuusmuuttaja käynnistetään HVAC-ohjauspaneelin 1. käynnistykseen assistantin avulla. Laajemmat käyttöönottotiedot annetaan *ACH580 firmware manual* -oppaassa (3AXD50000027537, englanninkielinen).

Ennen käynnistystä

Varmista, että taajuusmuuttaja on asennettu luvussa [FI – R6...R9 Asennuksen pikaopas](#) sivulla [55](#) (runkokoot R0...R9) kuvatulla tavalla.

R0-
R9

Käynnistys HVAC-ohjauspaneelin 1. käynnistykseen assistanti -toiminnon avulla

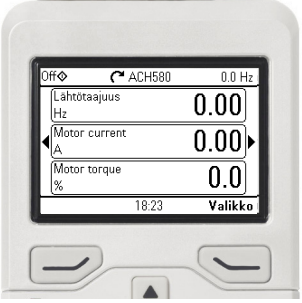
Turvallisuus	
<input type="checkbox"/>	Varmista, että asennustyö on valmis. Varmista, että taajuusmuuttajan kansi ja kaapelikotelo, jos se sisältyy kokoonpanoon, ovat paikoillaan.
<input type="checkbox"/>	 Varmista, että moottorin käynnistäminen ei aiheuta vaaraa. Kytke käytettävä laite irti , jos väärä pyörimissuunta voi vaurioittaa käytettävää laitetta.
Vihjeitä Assistant-ohjauspaneelin käyttöön	
<p>Näytön alareunan kaksi komentoa (oikealla olevassa kuvassa Options ja Menu) osoittavat näytön alla olevien kahden valintapainikkeen  ja  toiminnot. Valintapainikkeilla annettavat komennot vaihtelevat tilanteen mukaan.</p> <p>Painikkeilla , ,  ja  voidaan siirtää kohdistinta ja/tai muuttaa arvoja aktiivisessa näytössä.</p> <p>Painike  näyttää tilannekohtaisen ohjesivun.</p>	
1 – 1. käynnistykseen assistanti -toiminnon ohjatut asetukset: Kieli, moottorin nimellisarvot, päivämäärä ja aika	
<input type="checkbox"/>	Varmista, että moottorin arvokilven tiedot ovat saatavilla. Kytke taajuusmuuttajan virta.

FI

R0-R9



<p><input type="checkbox"/> 1. käynnistyksen assistantti -toiminto opastaa sinut ensimmäisen käynnistyksen läpi.</p> <p>Toiminto käynnistyy automaattisesti. Odota, kunnes ohjauspaneeliin aukeaa oikealla näkyvä näkymä.</p> <p>Valitse kieli, jota haluat käyttää, korostamalla se (jos se ei jo ole korostettuna) ja painamalla (OK) -painiketta.</p> <p>Huomautus: Kun olet valinnut kielen, ohjauspaneelin palautuminen kestää muutaman minuutin.</p>	
<p><input type="checkbox"/> Valitse Suorita ACH580:n käyttöönotto ja paina (Seuraava) -painiketta.</p>	

Tarkista seuraavat moottorin nimellisarvojen asetukset moottorin arvokilvestä. Syötä tarkalleen moottorin arvokilvestä annetut arvot.

Esimerkki induktiomootorin arvokilvestä:

ABB Motors

3 ~ motor M2AA 200 MLA 4

IEC 200 M/L 55

No

		Ins.cl.		F		IP 55	
V	Hz	kW	r/min	A	cos φ	IΔ/IN	tE/s
690 Y	50	30	1475	32.5	0.83		
400 D	50	30	1475	56	0.83		
660 Y	50	30	1470	34	0.83		
380 D	50	30	1470	59	0.83		
415 D	50	30	1475	54	0.83		
440 D	60	35	1770	59	0.83		













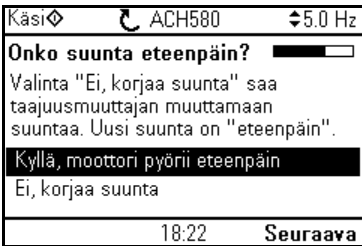

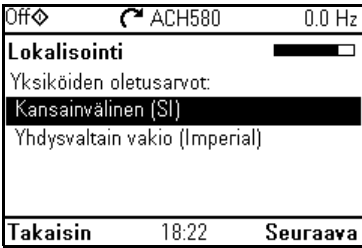

Cat. no 3GAA 202 001 - ADA

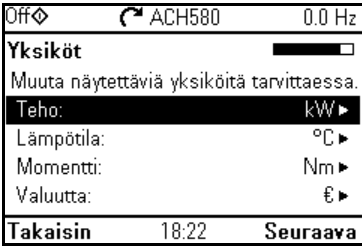
6312/C3		6210/C3	180 kg
---------	--	---------	--------

IEC 34-1

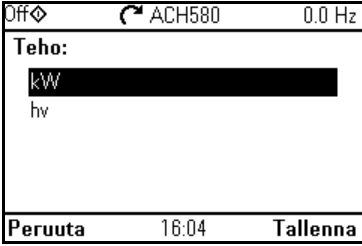
FI



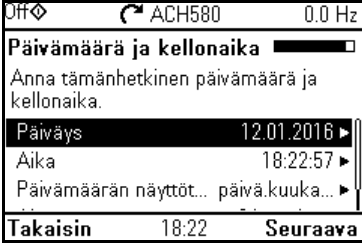

<input type="checkbox"/>	<p>Tarkista, että moottorin tiedot ovat oikein. Arvot on määritetty ennalta taajuusmuuttajan koon perusteella, mutta käyttäjän on tarkistettava, että ne vastaavat moottoria.</p> <p>Valitse ensimmäisenä moottorin tyyppi.</p> <ul style="list-style-type: none"> • Voit siirtyä valitun rivin muokkaustilaan painamalla -painiketta. • Voit selata tekstiä - ja -painikkeilla. <p>Moottorin nimellinen cosΦ ja nimellismomentti ovat valinnaisia.</p> <p>Jatka painamalla (Seuraava) -painiketta.</p>		<p>R0-R9</p>
<input type="checkbox"/>	<p>Arvon muuttaminen muokkausnäkyvässä:</p> <ul style="list-style-type: none"> • Siirrä kohdistinta vasemmalle tai oikealle - ja -painikkeilla. • Muuta arvoa - ja -painikkeilla. <p>Voit hyväksyä uuden asetuksen painamalla (Tallenna) -painiketta tai palata edelliseen näkymään tekemättä muutoksia painamalla (Peruuta) -painiketta.</p>		<p>FI</p>
<input type="checkbox"/>	<p>Tämä vaihe on valinnainen, ja se vaatii moottorin pyörittämistä. Älä tee tätä, jos siitä voi aiheutua vaaratilanne tai jos mekaaninen kokoonpano ei salli sitä.</p> <p>Voit tehdä suuntatestin valitsemalla Pyöritä moottoria -vaihtoehdon ja painamalla (Seuraava) -painiketta.</p>		
<input type="checkbox"/>	<p>Käynnistä taajuusmuuttaja painamalla paneelin Hand-painiketta .</p>		

<input type="checkbox"/>	<p>Tarkista moottorin pyörimissuunta.</p> <p>Jos se on eteenpäin, valitse vaihtoehto Kyllä, moottori pyörii eteenpäin ja jatka painamalla  (Seuraava) -painiketta.</p> <p>Jos suunta ei ole eteenpäin, valitse vaihtoehto Ei, korjaa suunta ja jatka painamalla  (Seuraava) -painiketta.</p>	
<input type="checkbox"/>	<p>Valitse mittayksikköjärjestelmä, jota haluat käyttää, ja paina  (Seuraava) -painiketta.</p>	
<input type="checkbox"/>	<p>Muuta tarvittaessa paneelissa näkyviä yksiköitä.</p> <ul style="list-style-type: none"> • Voit siirtyä valitun rivin muokkaustilaan painamalla  -painiketta. • Voit selata tekstiä  - ja  -painikkeilla. <p>Voit siirtyä seuraavaan näkymään painamalla  (Seuraava) -painiketta.</p>	
<input type="checkbox"/>	<p>Arvon valitseminen muokkausnäkyvässä:</p> <ul style="list-style-type: none"> • Valitse arvo  - ja  -painikkeilla. <p>Voit hyväksyä uuden asetuksen painamalla  (Tallenna) -painiketta tai palata edelliseen näkymään tekemättä muutoksia painamalla  (Peruuta) -painiketta.</p>	
<input type="checkbox"/>	<p>Aseta päivämäärä, aika sekä päivämäärän ja ajan esitysmuodot.</p> <ul style="list-style-type: none"> • Voit siirtyä valitun rivin muokkaustilaan painamalla  -painiketta. • Voit selata tekstiä  - ja  -painikkeilla. <p>Voit siirtyä seuraavaan näkymään painamalla  (Seuraava) -painiketta.</p>	

R0-R9

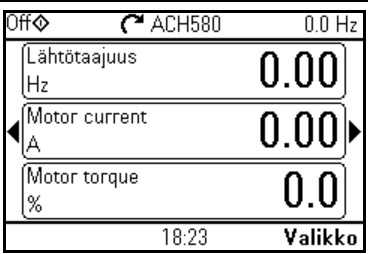

FI

<input type="checkbox"/>	<p>Voit antaa taajuusmuuttajalle nimen, joka näkyy ylimpänä, painamalla -painiketta. Jos et halua vaihtaa oletusnimeä (ACH580), jatka painamalla  (Seuraava).</p> <p>Tietoja tekstin muokkaamisesta on <i>ACH580 firmware manual</i> -oppaassa (3AXD50000027537, englanninkielinen).</p>	
<input type="checkbox"/>	<p>Ensimmäinen käynnistys on nyt tehty, ja taajuusmuuttaja on valmis käytettäväksi. Palaa aloitusnäyttöön painamalla  (Valmis)-painiketta.</p>	
<input type="checkbox"/>	<p>Paneelissa näkyy aloitusnäyttö, jossa valvotaan valittujen signaalien arvoja.</p>	

R0-R9



FI

2 – Käyttötilat: manuaalinen/off/automaattinen



- Taajuusmuuttaja voi olla kauko-ohjauksessa tai paikallishjauksessa. Paikallishjauksessa valittavana on lisäksi kaksi eri käyttötilaa.

Kauko-ohjaus: taajuusmuuttajaa ohjataan I/O-liitäntöjen tai kenttäväylän kautta.

- Näytön ylärivillä näkyy teksti Auto.

Paikallishjaus: taajuusmuuttajaa ohjataan ohjauspaneelin kautta.

- Jos näytön ylärivillä näkyy teksti Off, taajuusmuuttaja on Off-tilassa. Taajuusmuuttaja on tällöin pysäytetty.
- Jos näytön ylärivillä näkyy teksti Käsi, taajuusmuuttaja on manuaalisen ohjauksen tilassa. Taajuusmuuttaja on käynnissä. Tässä käyttötilassa aloitusohje kopioidaan taajuusmuuttajan ohjeesta.

Ylärivillä oleva -symboli tarkoittaa, että ohjetta voi muuttaa - ja -painikkeilla.

Seuraavasta kaaviosta nähdään, miten käyttötilaa voi muuttaa painamalla Hand-, Off- tai Auto-painiketta:

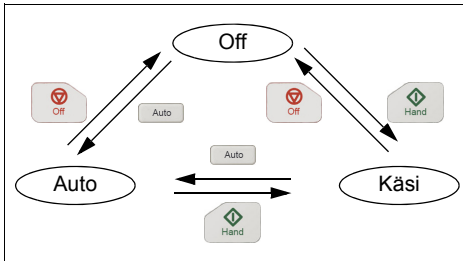



Huomaa: Jos taajuusmuuttaja käynnistetään uudelleen, kun vika 7081 Paneelivika on aktiivisena, käyttötila muuttuu Käsi- tai Off-tilasta Auto-tilaan.

Huomaa: Ohitustoiminnolla voidaan ohittaa käytössä oleva käyttötila. Katso *ACH580 firmware manual* -opas (3AXD50000027537, englanninkielinen).

Auto	 ACH580	30.0 Hz
Lähtötaajuus	Hz	30.04
Motor current	A	0.46
Motor torque	%	9.4
		13:27
		Valikko

Off	 ACH580	0.0 Hz
Lähtötaajuus	Hz	0.00
Motor current	A	0.00
Motor torque	%	0.0
		18:23
		Valikko

Käsi	 ACH580	 30.0 Hz
Lähtötaajuus	Hz	30.00
Motor current	A	0.45
Motor torque	%	9.4
		18:23
		Valikko

Ohje	 ACH580	30.3 Hz
 Vika 7081		
Apukoodi: 0000 0000		
Paneelivika		13:27:31
Ohjauspaneelin tiedonsiirtovika		
Piilota		13:27
		Kuittaa

R0-R9



FI

FR – Guide de mise en route









Ce guide décrit la mise en route du variateur à l'aide de l'assistant de démarrage de la micro-console HVAC. Pour une présentation détaillée de la mise en route, cf. *Manuel d'exploitation ACH580* (3AXD50000027595).

Avant de commencer

Vérifiez que le variateur a été monté conformément aux instructions du chapitre [FR – Guide d'installation R6...R9](#) page 65 (tailles R6 à R9).

R0-
R9

Mise en route avec l'assistant de la micro-console HVAC

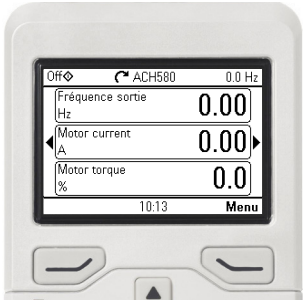
Sécurité	
<input type="checkbox"/>	Assurez-vous que le montage de l'appareil est terminé et que le capot du variateur ainsi que le boîtier d'entrée des câbles (si inclus à la livraison) sont en place.
<input type="checkbox"/>	 Vérifiez que le moteur peut être démarré en toute sécurité. Vous devez désaccoupler la machine entraînée si elle risque d'être endommagée en cas d'erreur de sens de rotation du moteur.
Conseils d'utilisation de la micro-console intelligente	
<p>Les deux commandes en bas de l'écran (Options et Menu sur la figure de droite) représentent les fonctions des deux touches  et  situées sous l'écran. Les commandes des touches de fonction varient selon le contexte.</p> <p>Les touches , ,  et  servent, selon la vue active, à déplacer le curseur et/ou à régler les valeurs.</p> <p>La touche  ouvre une page d'aide contextuelle.</p>	
1 – Réglages avec l'assistant de mise en service : Langue, valeurs nominales du moteur, date et heure	
<input type="checkbox"/>	<p>Gardez les données de la plaque signalétique du moteur à portée de main.</p> <p>Mettez le variateur sous tension.</p>

FR

L'assistant de mise en service vous guide pour la configuration initiale.

L'assistant démarre automatiquement. Attendez jusqu'à ce que la microconsole affiche l'écran illustré à droite.

Pour sélectionner la langue de votre choix, mettez-la en surbrillance (si elle ne l'est pas déjà) et appuyez sur  (OK).

N.B. : Après avoir sélectionné la langue, vous devrez patienter quelques minutes que la microconsole reprenne son activité.



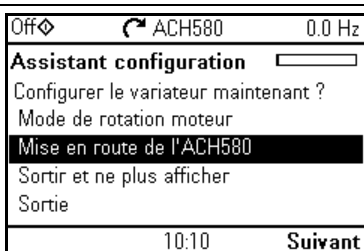

Sélectionnez **Mise en route de l'ACH580** et enfoncez la touche  (Suivant).



Reportez-vous à la plaque signalétique du moteur pour régler les valeurs nominales du moteur. Entrez les valeurs exactes de la plaque signalétique du moteur.

Exemple de plaque signalétique d'un moteur asynchrone :













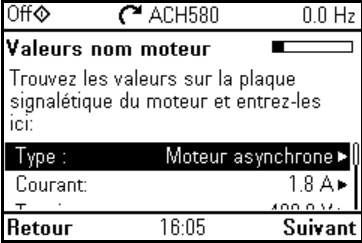

V		Hz	kW	r/min	A	cos ϕ	IA/IN	tE/s
690 Y	50	30	1475	32.5	0.83			
400 D	50	30	1475	56	0.83			
660 Y	50	30	1470	34	0.83			
380 D	50	30	1470	59	0.83			
415 D	50	30	1475	54	0.83			
440 D	60	35	1770	59	0.83			

3 ~ motor		M2AA 200 MLA 4		
		IEC 200 M/L 55		
		No		
		Ins.cl. F		IP 55
Cat. no		3GAA 202 001 - ADA		
6312/C3		6210/C3	180	kg
IEC 34-1				

R0-R9

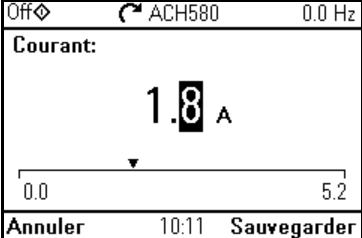

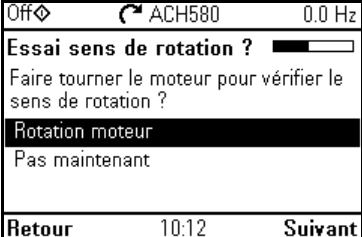
FR

<p><input type="checkbox"/> Assurez-vous que les données moteur sont correctes. Les valeurs sont préréglées en fonction de la taille de l'appareil mais vous devez vérifier qu'elles correspondent bien au moteur.</p> <p>Commencez par le type de moteur.</p> <ul style="list-style-type: none"> • Pour modifier une ligne en surbrillance, enfoncez la touche . • Faites défiler le contenu de l'affichage avec les touches  et . <p>Les réglages du cos phi nominal et du couple nominal sont facultatifs.</p> <p>Enfoncez  (Suivant) pour continuer.</p>	
<p><input type="checkbox"/> Modification d'une valeur dans une vue :</p> <ul style="list-style-type: none"> • Déplacez le curseur vers la droite ou la gauche avec les touches  et . • Ajustez la valeur avec  et . <p>Enfoncez  (Sauvegarder) pour sauvegarder votre réglage ou  (Annuler) pour annuler les modifications et revenir à l'écran précédent.</p>	
<p><input type="checkbox"/> Cette étape facultative nécessite de faire tourner le moteur. Ne l'effectuez pas si elle présente le moindre risque ou si la configuration mécanique ne s'y prête pas.</p> <p>Pour vérifier le sens de rotation, mettez Rotation moteur en surbrillance et appuyez sur  (Suivant).</p>	
<p><input type="checkbox"/> Enfoncez la touche Hand  de la microconsole pour démarrer le variateur.</p>	

R0-R9







FR

R0-
R9

FR

<input type="checkbox"/>	<p>Vérifiez le sens de rotation du moteur.</p> <p>S'il tourne en sens avant, sélectionnez Oui, rotation en sens avant et enfoncez (Suivant) pour poursuivre.</p> <p>Dans le cas contraire, sélectionnez Non, sens de rotation fixe et enfoncez (Suivant) pour poursuivre.</p>	
<input type="checkbox"/>	<p>Choisissez le système d'unités que vous souhaitez utiliser et appuyez sur (Suivant).</p>	
<input type="checkbox"/>	<p>Modifiez les unités présentées sur la micro-console si nécessaire.</p> <ul style="list-style-type: none"> • Pour modifier une ligne en surbrillance, enfoncez la touche . • Faites défiler le contenu de l'affichage avec les touches et . <p>Pour passer à l'écran suivant, appuyez sur (Suivant).</p>	
<input type="checkbox"/>	<p>Modification d'une valeur dans une vue :</p> <ul style="list-style-type: none"> • Sélectionnez la valeur avec et . <p>Enfoncez (Sauvegarder) pour sauvegarder votre réglage ou (Annuler) pour annuler les modifications et revenir à l'écran précédent.</p>	
<input type="checkbox"/>	<p>Réglez la date, l'heure et les formats d'affichage de la date et de l'heure.</p> <ul style="list-style-type: none"> • Pour modifier une ligne en surbrillance, enfoncez la touche . • Faites défiler le contenu de l'affichage avec les touches et . <p>Pour passer à l'écran suivant, appuyez sur (Suivant).</p>	

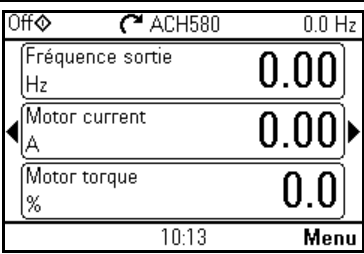
<input type="checkbox"/>	<p>Pour donner un nom au variateur (qui s'affichera en haut), appuyez sur .</p> <p>Si vous souhaitez conserver le nom préréglé (ACH580), enfoncez la touche  (Suivant).</p> <p>Pour en savoir plus sur la saisie de texte, cf. <i>Manuel d'exploitation ACH580</i> (3AXD50000027595).</p>	
<input type="checkbox"/>	<p>La première mise en route est maintenant terminée, et le variateur est prêt à fonctionner.</p> <p>Enfoncez la touche  (Fait) pour accéder à la vue Accueil.</p>	
<input type="checkbox"/>	<p>La vue Accueil, qui permet de visualiser les valeurs des signaux sélectionnés, s'affiche à l'écran.</p>	

R0-
R9

FR

2 – Fonctionnement en mode Manuel/Off/Auto



- Le variateur peut fonctionner en commande locale ou externe (à distance). Deux modes supplémentaires sont disponibles en commande locale.

Commande externe : variateur commandé par les E/S ou le bus de terrain.

- «Auto» s'affiche sur la ligne du haut.

Commande locale : variateur commandé par la micro-console.

- «Off» s'affiche sur la ligne du haut si le variateur est en mode Off, c'est-à-dire arrêté.
- «Manuel» s'affiche sur la ligne du haut si le variateur est en mode Manuel, c'est-à-dire en cours de fonctionnement. Dans ce mode, la référence initiale est copiée depuis la référence du variateur.

Le symbole  sur la ligne supérieure indique que les touches  et  servent à faire changer la référence.

Le schéma ci-dessous présente les transitions d'état lorsque l'opérateur enfonce la touche Hand, Off ou Auto :

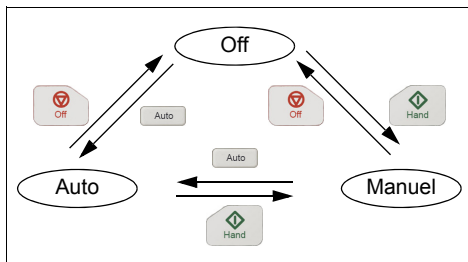

N.B. : Si le variateur redémarre avec le défaut 7081 Perte microconsole actif, le mode de fonctionnement passe de Manuel ou Off à Auto.

N.B. : Le fonctionnement en marche forcée (Override) a priorité sur le mode de fonctionnement actif. Cf. manuel anglais *ACH580 firmware manual* (3AXD50000027537).

Auto	ACH580	30.0 Hz
Fréquence sortie Hz	30.04	
Motor current A	0.46	
Motor torque %	9.4	
10:13		Menu

Off	ACH580	0.0 Hz
Fréquence sortie Hz	0.00	
Motor current A	0.00	
Motor torque %	0.0	
10:13		Menu

Manu.	ACH580	↕ 30.0 Hz
Fréquence sortie Hz	30.00	
Motor current A	0.45	
Motor torque %	9.4	
Référence	10:19	Menu

Off	ACH580	0.0 Hz
✘ Default 7081		
Code AUX: 0000 0000		
Perte microconsole	10:19:35	
Défaut perte microconsole		
Masquer	10:19	Réarmement

R0-R9



FR

IT – Guida rapida all'avviamento









Questa guida descrive come avviare il convertitore di frequenza utilizzando la funzione di assistenza al primo avviamento sul pannello di controllo HVAC. Per le informazioni complete sull'avviamento, vedere *ACH580 firmware manual* (3AXD50000027537 [inglese]).

Prima di iniziare

Verificare che il convertitore sia stato installato come descritto nel capitolo *IT – Guida rapida all'installazione R6...R9* a pag. 75 (telai R6...R9).

R0-
R9



Avviamento con la funzione di assistenza del pannello di controllo HVAC

Sicurezza	
<input type="checkbox"/>	Verificare che l'installazione sia stata completata. Verificare che siano installati il coperchio del convertitore e la cassetta dei cavi, se inclusa.
<input type="checkbox"/>	 Controllare che l'avviamento del motore non determini situazioni di pericolo. Disaccoppiare la macchina comandata qualora vi sia rischio di danni in caso di direzione di rotazione sbagliata.
Come utilizzare il pannello di controllo Assistant	
<p>I due comandi in basso sullo schermo (Opzioni e Menu nella figura a destra) corrispondono alle funzioni dei due tasti software  e  posizionati sotto il display. I comandi assegnati ai tasti software variano in base al contesto.</p> <p>Utilizzare i tasti , ,  e  per spostare il cursore e/o modificare i valori in base alla visualizzazione attiva.</p> <p>Il tasto  richiama una pagina di aiuti sensibili al contesto.</p>	
1 – Impostazioni guidate al primo avviamento: lingua, valori nominali del motore, data e ora	
<input type="checkbox"/>	Tenere a portata di mano i dati di targa del motore. Accendere il convertitore.

IT



R0-
R9

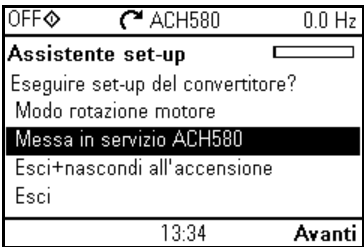















☐	<p>La funzione di assistenza al primo avviamento guida l'utente durante il primo avviamento.</p> <p>La funzione di assistenza si avvia automaticamente. Attendere finché sul pannello di controllo non compare la schermata della figura a destra.</p> <p>Selezionare la lingua dell'interfaccia: evidenziarla (a meno che non sia già evidenziata) e premere  (OK).</p> <p>Nota: dopo aver selezionato la lingua, attendere qualche minuto la riattivazione del pannello di controllo.</p>	
☐	<p>Selezionare Messa in servizio ACH580 e premere  (Avanti).</p>	

Per le seguenti impostazioni dei valori nominali del motore, fare riferimento ai dati riportati sulla targa del motore. I valori devono essere inseriti esattamente come compaiono sulla targa del motore.

Esempio di targa di un motore a induzione (asincrono):

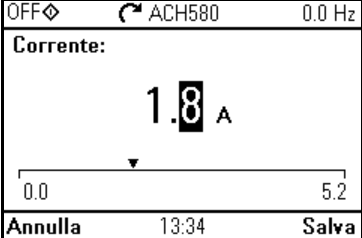
ABB Motors 									
3 ~ motor		M2AA 200 MLA 4							
IEC 200 M/L 55 									
No									
Ins.cl. F					IP 55				
V	Hz	kW	r/min	A	cos φ	IA/IN	tE/s		
690 Y	50	30	1475	32.5	0.83				
400 D	50	30	1475	56	0.83				
660 Y	50	30	1470	34	0.83				
380 D	50	30	1470	59	0.83				
415 D	50	30	1475	54	0.83				
440 D	60	35	1770	59	0.83				
Cat. no		3GAA 202 001 - ADA							
6312/C3			 6210/C3				180 kg		
IEC 34-1									

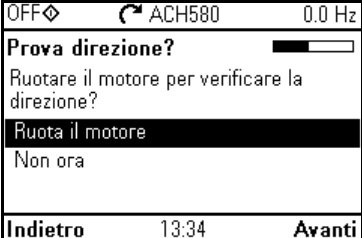
IT

<p><input type="checkbox"/> Controllare che i dati del motore siano corretti. I valori sono predefiniti sulla base del telaio del convertitore, ma è necessario verificare che corrispondano al motore.</p> <p>Iniziare dal tipo di motore.</p> <ul style="list-style-type: none"> • Per modificare la riga selezionata, premere . • Scorrere verso l'alto e verso il basso con i tasti  e . <p>I valori di $\cos\Phi$ nominale e coppia nominale del motore sono facoltativi.</p> <p>Premere  (Avanti) per continuare.</p>	
<p><input type="checkbox"/> Per modificare un valore:</p> <ul style="list-style-type: none"> • Per spostare il cursore a destra e a sinistra, premere  e . • Per modificare il valore, premere  e . <p>Premere  (Salva) per accettare la nuova impostazione o  (Annulla) per tornare alla schermata precedente senza effettuare modifiche.</p>	
<p><input type="checkbox"/> Questo passaggio è facoltativo e richiede la rotazione del motore. Non eseguirlo se può creare situazioni di pericolo o se la configurazione meccanica non lo consente.</p> <p>Per eseguire la prova di rotazione del motore, selezionare Ruota il motore e premere  (Avanti).</p>	
<p><input type="checkbox"/> Premere il tasto Hand  sul pannello per avviare il convertitore.</p>	



R0-
R9

IT

R0-
R9

IT

<input type="checkbox"/>	<p>Controllare la direzione di rotazione del motore. Se è "avanti", selezionare Si, il motore ruota in avanti e premere (Avanti) per continuare. Se la direzione è "indietro", selezionare No, cambia direzione e premere (Avanti) per continuare.</p>	
<input type="checkbox"/>	<p>Selezionare il sistema di unità di misura e premere (Avanti).</p>	
<input type="checkbox"/>	<p>Se necessario, modificare le unità visualizzate sul pannello.</p> <ul style="list-style-type: none"> • Per modificare la riga selezionata, premere . • Scorrere verso l'alto e verso il basso con i tasti e . <p>Passare alla schermata successiva premendo (Avanti).</p>	
<input type="checkbox"/>	<p>Per selezionare un valore:</p> <ul style="list-style-type: none"> • Per selezionare il valore, premere e . <p>Premere (Salva) per accettare la nuova impostazione o (Annulla) per tornare alla schermata precedente senza effettuare modifiche.</p>	
<input type="checkbox"/>	<p>Impostare data, ora e i relativi formati.</p> <ul style="list-style-type: none"> • Per modificare la riga selezionata, premere . • Scorrere verso l'alto e verso il basso con i tasti e . <p>Passare alla schermata successiva premendo (Avanti).</p>	

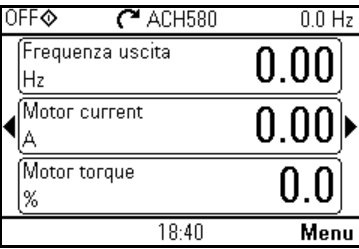
<input type="checkbox"/>	<p>Premere [▶] per dare un nome al convertitore, che comparirà in alto sullo schermo.</p> <p>Se non si desidera cambiare il nome di default (ACH580), premere [↵] (Avanti) per continuare.</p> <p>Per informazioni sulla modifica dei testi, vedere <i>ACH580 firmware manual</i> (3AXD50000027537 [inglese]).</p>	
<input type="checkbox"/>	<p>A questo punto il primo avviamento è terminato e il convertitore di frequenza è pronto all'uso.</p> <p>Premere [↵] (Fatto) per andare alla schermata Home.</p>	
<input type="checkbox"/>	<p>Sul pannello compare la schermata Home, da cui si esegue il monitoraggio dei segnali selezionati.</p>	

R0-R9



IT

2 – Funzionamento Hand/Off/Auto

- Il convertitore di frequenza può trovarsi in modalità di controllo remoto o controllo locale. Il controllo locale prevede a sua volta due diverse modalità operative.

Controllo remoto: il convertitore è controllato dagli I/O o dal bus di campo.

- Sulla riga in alto del display compare la scritta "Auto".

Controllo locale: il convertitore è controllato dal pannello di controllo.

- Sulla riga in alto del display compare la scritta "Off", a indicare che il convertitore è fermo.
- Sulla riga in alto compare la scritta "Manu.", a indicare che il convertitore è in modalità manuale. Il convertitore è in funzione. Il riferimento iniziale in modalità Manuale viene copiato dal riferimento del convertitore.

Il simbolo \blacklozenge sulla riga in alto indica che è possibile modificare il riferimento con \blacktriangleup e \blacktriangledown .

Lo schema seguente mostra le transizioni di stato quando si premono i pulsanti Hand, Off e Auto:

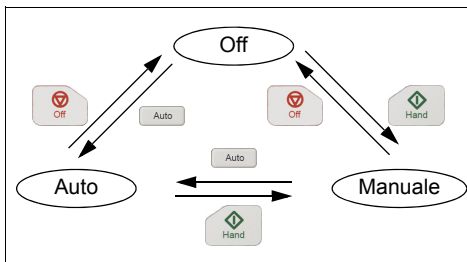

Nota: se si riavvia il convertitore quando è attivo il guasto 7081 Control panel loss, la modalità passa da Manuale o Off ad Auto.

Nota: i comandi di funzionamento forzato prevalgono sulla modalità operativa attiva al momento. Vedere *ACH580 Firmware Manual (3AXD50000027537 [inglese])*.

Auto	ACH580	30.0 Hz
Frequenza uscita Hz	30.04	
Motor current A	0.46	
Motor torque %	9.4	
18:40		Menu

OFF \blacklozenge	ACH580	0.0 Hz
Frequenza uscita Hz	0.00	
Motor current A	0.00	
Motor torque %	0.0	
18:40		Menu

Manu. \blacklozenge	ACH580	↕ 30.0 Hz
Frequenza uscita Hz	30.00	
Motor current A	0.45	
Motor torque %	9.4	
Riferimento	18:40	Menu

OFF \blacklozenge	ACH580	0.0 Hz
Guasto 7081	Codice AUX: 0000 0000	
Perdita pannello	18:36:48	
Guasto per perdita pannello di controllo		
Nascondi	18:37	Reset

R0-R9



IT

NL – Beknopte opstartgids









Deze gids beschrijft het opstarten van de omvormer via de Eerste-start assistent op het HVAC bedieningspaneel. Zie, voor complete informatie over opstarten *ACH580 firmware manual* (3AXD50000027537 [Engels]).

Vóór het starten

Zorg er voor dat de omvormer geïnstalleerd is zoals beschreven in hoofdstuk [NL – R6...R9 Beknopte installatiegids](#) op pagina [85](#) (frames R6...R9).

R0-
R9



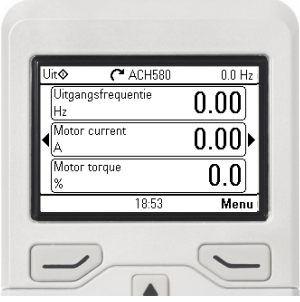

Opstarten met de Eerste-start assistent op een HVAC bedieningspaneel

Veiligheid	
<input type="checkbox"/>	Controleer dat de installatiewerkzaamheden voltooid zijn. Controleer dat de omvormermerk en het kabelingangsblok, indien meegeleverd, op hun plaats zitten.
<input type="checkbox"/>	 Controleer of het starten van de motor geen gevaar oplevert. Ontkoppel de aangedreven machine als er een risico van schade bestaat bij een eventueel verkeerde draairichting.
Tips bij het gebruik van het assistent-bedieningspaneel	
<p>De twee commando's onder aan het display (Opties en Menu in de figuur rechts), tonen de functies van de twee softkeys  en  die zich onder het display bevinden. De commando's die aan de softkeys toegewezen zijn variëren afhankelijk van de context.</p> <p>Gebruik de toetsen , ,  en  om de cursor te bewegen en/of waarden te wijzigen, afhankelijk van het actieve scherm.</p> <p>De toets  toont een context-gevoelige help-pagina.</p>	
1 – Geleide instellingen van de Eerste start assistent: Taal, nominale motorwaarden, en datum en tijd	
<input type="checkbox"/>	Houd de gegevens van het motortypeplaatje bij u. Schakel de voeding van de omvormer in.

NL



R0-
R9

























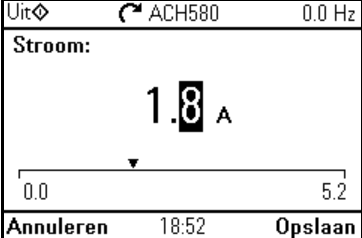

<input type="checkbox"/>	<p>De Eerste start assistent leidt u door de eerste keer opstarten.</p> <p>De assistent begint automatisch. Wacht totdat het bedieningspaneel het scherm rechts hiernaast toont.</p> <p>Kies de taal die u wilt gebruiken door deze te markeren (indien deze nog niet gemarkeerd is) en op  (OK) te drukken.</p> <p>Opmerking: Nadat u de taal geselecteerd heeft, duurt het een paar minuten voordat het bedieningspaneel gewekt is.</p>	
<input type="checkbox"/>	<p>Selecteer In bedrijf nemen van de ACH580 en druk op  (Volgende).</p>	

Raadpleeg het motortypeplaatje voor de volgende instellingen van de nominale waarden van de motor. Voer de waarden exact hetzelfde in als op het motortypeplaatje.

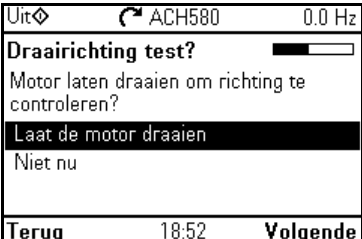
Voorbeeld van een typeplaatje van een (asynchrone) inductiemotor:

ABB Motors 										
3 ~ motor		M2AA 200 MLA 4								
IEC 200 M/L 55 										
No										
Ins.cl. F					IP 55					
V	Hz	kW	r/min	A	cos φ	IA/IN	tE/s			
690 Y	50	30	1475	32.5	0.83					
400 D	50	30	1475	56	0.83					
660 Y	50	30	1470	34	0.83					
380 D	50	30	1470	59	0.83					
415 D	50	30	1475	54	0.83					
440 D	60	35	1770	59	0.83					
Cat. no 3GAA 202 001 - ADA										
6312/C3							6210/C3		180 kg	
IEC 34-1										

NL

<p><input type="checkbox"/> Controleer dat de motorgegevens juist zijn. De waarden zijn voorgedefinieerd op basis van omvormergrootte, maar u dient te verifiëren dat ze overeenkomen met de motor.</p> <p>Begin met het motortype.</p> <ul style="list-style-type: none"> • Ga naar het bewerksscherm van een geselecteerde regel door op  te drukken. • Scroll door het scherm met  en . <p>Nominale $\cos\Phi$ en nominaal koppel van de motor zijn optioneel.</p> <p>Druk op  (Volgende) om door te gaan.</p>	 <p>Uit  ACH580 0.0 Hz</p> <p>Nominale waarden motor </p> <p>Kijk naar de waarden op het motortypeplaatje en voer ze hier in:</p> <p>Type: Asynchrone motor </p> <p>Stroom: 1.8 A </p> <p>Spanning: 400.0 V </p> <p>Terug 18:09 Volgende</p>
<p><input type="checkbox"/> Om een waarde te wijzigen in een bewerkingscherm:</p> <ul style="list-style-type: none"> • Gebruik  en  om de cursor naar links en rechts te verplaatsen. • Gebruik  en  om de waarde te wijzigen. <p>Druk op  (Opslaan) om de nieuwe instelling te accepteren, of druk op  (Annuleren) om terug te gaan naar het vorige scherm zonder iets te wijzigen.</p>	 <p>Uit  ACH580 0.0 Hz</p> <p>Stroom:</p> <p>1.8 A</p> <p>0.0 5.2</p> <p>Annuleren 18:52 Opslaan</p>
<p><input type="checkbox"/> Deze stap is optioneel, en vereist dat de motor gedraaid wordt. Doe dit niet als het enig risico met zich meebrengt, of als de mechanische opstelling dit niet toestaat.</p> <p>Om de draairichtingstest uit te voeren, markeert u Laat de motor draaien en drukt u op  (Volgende).</p>	 <p>Uit  ACH580 0.0 Hz</p> <p>Draairichting test? </p> <p>Motor laten draaien om richting te controleren?</p> <p>Laat de motor draaien</p> <p>Niet nu</p> <p>Terug 18:52 Volgende</p>
<p><input type="checkbox"/> Druk op de Hand-toets  op het paneel om de omvormer te starten.</p>	 <p>Uit  ACH580 5.0 Hz</p> <p>Druk op Hand </p> <p>Waarschuwing: Totdat set-up voltooid is, zijn veiligheidsfuncties niet actief en is het motortoerental 5 Hz.</p> <p>Druk nu op Hand om de motor te laten draaien, en controleer daarna de</p> <p>Terug 18:52</p>

R0-R9



NL

R0-R9



NL

<p><input type="checkbox"/> Controleer de draairichting van de motor. Als deze voorwaarts is, selecteer dan Ja, motor draait voorwaarts en druk op (Volgende) om door te gaan. Als de draairichting niet voorwaarts is, markeer dan Nee, leg richting vast en druk op (Volgende) om door te gaan.</p>	
<p><input type="checkbox"/> Selecteer de lokalisatie die u wilt gebruiken en druk op (Volgende).</p>	
<p><input type="checkbox"/> Wijzig zo nodig de eenheden die op het paneel te zien zijn. • Ga naar het bewerksscherm van een geselecteerde regel door op te drukken. • Scroll door het scherm met en .</p> <p>Ga naar het volgende scherm door op (Volgende) te drukken.</p>	
<p><input type="checkbox"/> Om een waarde te selecteren in een bewerkingsscherm: • Gebruik en om de waarde te selecteren. Druk op (Opslaan) om de nieuwe instelling te accepteren, of druk op (Annuleren) om terug te gaan naar het vorige scherm zonder iets te wijzigen.</p>	
<p><input type="checkbox"/> Stel de datum en tijd in, en ook de displayformats van datum en tijd. • Ga naar het bewerksscherm van een geselecteerde regel door op te drukken. • Scroll door het scherm met en .</p> <p>Ga naar het volgende scherm door op (Volgende) te drukken.</p>	

<input type="checkbox"/>	<p>Om de omvormer een naam te geven die bovenaan wordt weergegeven drukt u op . Als u de standaard naam niet wilt wijzigen (ACH580), ga dan verder door op (Volgende) te drukken. Voor informatie over het bewerken van tekst, zie <i>ACH580 firmware manual</i> (3AXD5000027537 [Engels]).</p>	
<input type="checkbox"/>	<p>De eerste start is nu voltooid en de omvormer is gereed voor gebruik. Druk op (Gereed) om naar het Home-scherm te gaan.</p>	
<input type="checkbox"/>	<p>Het Home-scherm, dat de waarden van de geselecteerde signalen monitort, wordt op het paneel getoond.</p>	

R0-R9



NL

2 – Hand/Uit/Auto bediening

De omvormer kan onder afstandsbesturing of lokale besturing staan, en onder lokale besturing zijn er ook nog twee verschillende modi.

Afstandsbediening: Omvormer wordt bestuurd vanaf de I/O of de veldbus.

- Bovenste regel van het scherm toont Auto.

Lokale besturing: Omvormer wordt bestuurd vanaf het bedieningspaneel.

- Bovenste regel van het scherm toont Uit, dat wil zeggen, de omvormer is in de Uit-modus. Omvormer gestopt.
- Bovenste regel van het scherm toont Hand, dat wil zeggen, de omvormer is in de Hand-modus. Omvormer is in bedrijf. De beginreferentie in de Hand-modus wordt gekopieerd van de omvormer-referentie.

Symbool \blacklozenge op de bovenste regel geeft aan dat u de referentie kunt veranderen met \blacktriangleup en \blacktriangledown .

Het volgende diagram toont de toestandsveranderingen wanneer u op de Hand, Off of Auto knop drukt:

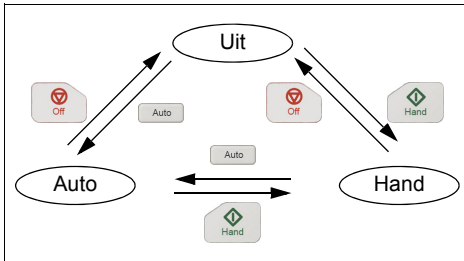

Opmerking: Wanneer u de omvormer opnieuw opstart terwijl fout 7081 Control panel loss actief is, wijzigt de modus van Hand of Uit naar Auto.

Opmerking: Override bedrijf heeft prioriteit op de actuele bedrijfsmodus. Zie *ACH580 firmware manual* (3AXD50000027537 [Engels]).

Auto	ACH580	30.0 Hz
Uitgangsfrequentie	Hz	30.04
Motor current	A	0.46
Motor torque	%	9.4
		13:58 Menu

Uit	ACH580	0.0 Hz
Uitgangsfrequentie	Hz	0.00
Motor current	A	0.00
Motor torque	%	0.0
		18:53 Menu

Hand	ACH580	↕ 30.0 Hz
Uitgangsfrequentie	Hz	30.00
Motor current	A	0.45
Motor torque	%	9.4
Referentie	13:58	Menu

Uit	ACH580	0.0 Hz
Fout 7081	Aux code: 0000 0000	
Bed.paneel kwijt	Di 12.01.	
Fout bedieningspaneel kwijt		
Verbergen	13:57	Reset

R0-R9



NL

PL – Skrócona instrukcja uruchamiania









Ta instrukcja opisuje sposób uruchamiania przemiennika częstotliwości przy użyciu Asystenta pierwszego uruchamiania na panelu sterowania HVAC. Pełne informacje dotyczące uruchamiania zawiera podręcznik *ACH580 firmware manual* (3AXD50000027537, w języku angielskim).

Przed rozpoczęciem

Należy sprawdzić, czy przemiennik częstotliwości został zamontowany zgodnie z opisem w rozdziale *PL – Skrócona instrukcja montażu – obudowy R6...R9* na stronie 95 (obudowy R0...R9).

R0-
R9

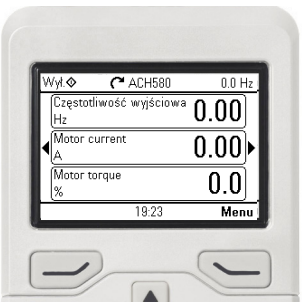

Uruchamianie przy użyciu Asystenta pierwszego uruchamiania na panelu sterowania HVAC

Bezpieczeństwo	
<input type="checkbox"/>	Upewnić się, że prace montażowe zostały zakończone. Sprawdź, czy osłony przemiennika częstotliwości i skrzynki kablowej znajdują się na miejscu.
<input type="checkbox"/>	 Sprawdzić, czy uruchomienie silnika nie spowoduje żadnego niebezpieczeństwa. Odłączyć napędzane urządzenie , jeśli istnieje ryzyko uszkodzenia przez niewłaściwy kierunek obrotów silnika.
Wskazówki dotyczące obsługi panelu sterowania z asystentami	
<p>Dwie komendy znajdujące się w dolnej części wyświetlacza (Options i Menu widoczne na ilustracji po prawej stronie) odpowiadają funkcjom dwóch przycisków  i  znajdujących się pod wyświetlaczem. Te dwie funkcje przypisane do przycisków mogą być różne w zależności od kontekstu.</p> <p>Należy użyć klawiszy , ,  i  do przesuwania kursora i/lub zmiany wartości w zależności od aktywnego widoku.</p> <p>Klawisz  powoduje wyświetlenie strony pomocy uzależnionej od kontekstu.</p>	
1 – Ustawienia Asystenta pierwszego uruchamiania: Język, wartości znamionowe silnika oraz data i godzina	
<input type="checkbox"/>	<p>Przygotować dane z tabliczki znamionowej silnika.</p> <p>Włączyć przemiennik częstotliwości.</p>

PL

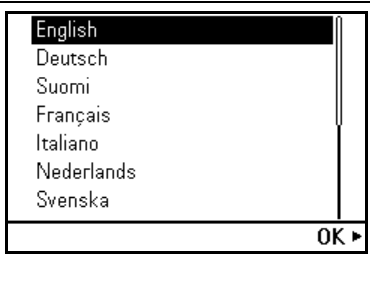

R0-
R9

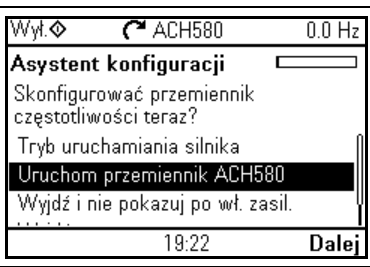













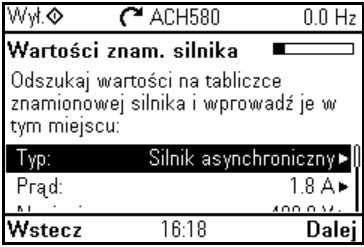

<input type="checkbox"/>	<p>Asystent pierwszego uruchamiania wspiera użytkownika podczas pierwszego uruchomienia. Jest on uruchamiany automatycznie. Zaczekać, aż na panelu sterowania pojawi się widok przedstawiony po prawej stronie.</p> <p>Wybrać żądany język, podświetlając go (jeśli nie jest już podświetlony), i nacisnąć przycisk  (OK).</p> <p>Uwaga: Po wybraniu języka wzbudzenie panelu sterowania zajmuje kilka minut.</p>	
<input type="checkbox"/>	<p>Wybrać opcję Uruchom przemiennik ACH580 i nacisnąć przycisk  (Dalej).</p>	

Tabliczka znamionowa silnika przedstawia następujące ustawienia wartości znamionowych silnika. Należy wprowadzić wartości dokładnie takie, jakie przedstawia tabliczka znamionowa silnika.

Przykładowa tabliczka znamionowa silnika indukcyjnego (asynchronicznego):

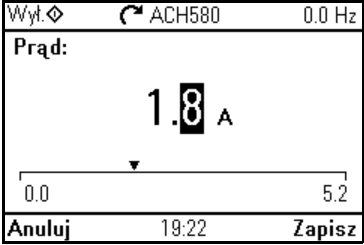
 ABB Motors 									
3 ~ motor		M2AA 200 MLA 4							
		IEC 200 M/L 55							
		No		Ins.cl. F		IP 55			
V	Hz	kW	r/min	A	cos φ	IA/IN	tE/s		
690 Y	50	30	1475	32.5	0.83				
400 D	50	30	1475	56	0.83				
660 Y	50	30	1470	34	0.83				
380 D	50	30	1470	59	0.83				
415 D	50	30	1475	54	0.83				
440 D	60	35	1770	59	0.83				
Cat. no		3GAA 202 001 - ADA							
6312/C3				6210/C3		180 kg			
IEC 34-1									

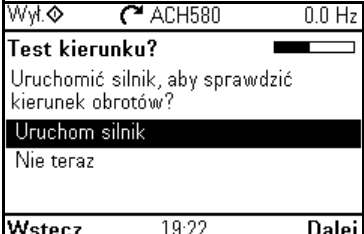



PL

<p><input type="checkbox"/> Sprawdzić, czy dane silnika są prawidłowe. Wartości są wstępnie zdefiniowane na podstawie wielkości przemiennika częstotliwości, ale należy sprawdzić, czy odpowiadają one silnikowi.</p> <p>Rozpocząć od typu silnika.</p> <ul style="list-style-type: none"> Przejsć do widoku edycji wybranego wiersza, naciskając przycisk . Widok można przewijać przy użyciu przycisków  i . <p>Wartość znamionowego $\cos\Phi$ i wartość znamionowego momentu obrotowego silnika są opcjonalne.</p> <p>Nacisnąć przycisk  (Dalej), aby kontynuować.</p>	
<p><input type="checkbox"/> Aby zmienić wartość w widoku edycji:</p> <ul style="list-style-type: none"> Za pomocą przycisków  i  przesunąć kursor w lewo lub prawo. Przy użyciu przycisków  i  zmienić wartość. <p>Nacisnąć przycisk  (Zapisz) aby zatwierdzić nowe ustawienie, lub nacisnąć przycisk  (Anuluj) aby wrócić do poprzedniego widoku bez wprowadzania zmian.</p>	
<p><input type="checkbox"/> Ten krok jest opcjonalny i wymaga obracania silnika. Nie należy wykonywać tego kroku, jeśli może on spowodować jakiegokolwiek ryzyko lub na jego użycie nie pozwala konfiguracja mechaniczna.</p> <p>Aby wykonać test kierunku, wybrać opcję Uruchom silnik i nacisnąć przycisk  (Dalej).</p>	
<p><input type="checkbox"/> Nacisnąć przycisk Hand  na panelu, aby uruchomić przemiennik częstotliwości.</p>	

R0-
R9

<input type="checkbox"/>	<p>Sprawdzić kierunek obrotów silnika.</p> <p>Jeśli silnik obraca się do przodu, wybrać opcję Tak, silnik obraca się do przodu, a następnie nacisnąć przycisk (Dalej) aby kontynuować.</p> <p>Jeśli silnik nie obraca się do przodu, wybrać opcję Nie, ustal kierunek, a następnie nacisnąć przycisk (Dalej), aby kontynuować.</p>	
<input type="checkbox"/>	<p>Wybrać lokalizację, która ma zostać użyta, i nacisnąć przycisk (Dalej).</p>	
<input type="checkbox"/>	<p>W razie potrzeby zmienić jednostki wyświetlone na panelu.</p> <ul style="list-style-type: none"> Przejsz do widoku edycji wybranego wiersza, naciskając przycisk . Widok można przewijać przy użyciu przycisków i . <p>Przejsz do następnego widoku, naciskając przycisk (Dalej).</p>	
<input type="checkbox"/>	<p>Aby wybrać wartość w widoku edycji:</p> <ul style="list-style-type: none"> Przy użyciu przycisków i wybrać wartość. <p>Nacisnąć przycisk (Zapisz), aby zatwierdzić nowe ustawienie, lub nacisnąć przycisk (Anuluj), aby wrócić do poprzedniego widoku bez wprowadzania zmian.</p>	
<input type="checkbox"/>	<p>Ustawić datę i godzinę oraz format wyświetlania daty i godziny.</p> <ul style="list-style-type: none"> Przejsz do widoku edycji wybranego wiersza, naciskając przycisk . Widok można przewijać przy użyciu przycisków i . <p>Przejsz do następnego widoku, naciskając przycisk (Dalej).</p>	

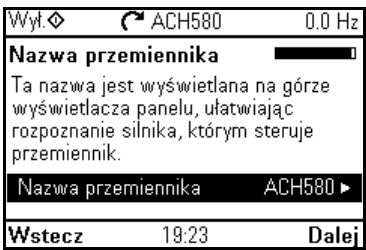
PL

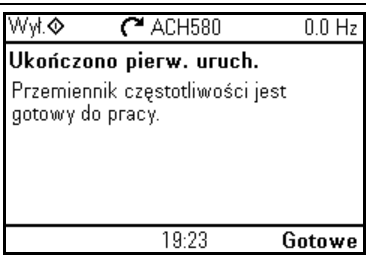
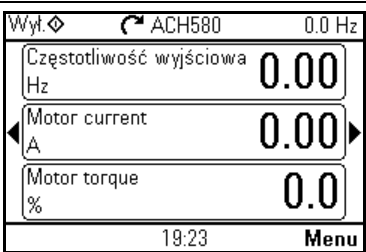
<input type="checkbox"/>	<p>Aby nadać przemiennikowi częstotliwości nazwę, która będzie wyświetlana w górnej części ekranu, naciśnij przycisk .</p> <p>Jeśli domyślna nazwa (ACH580) ma pozostać niezmienną, przejdź dalej, naciskając przycisk  (Dalej)</p> <p>Więcej informacji na temat edytowania tekstu zawiera dokument <i>ACH580 firmware manual</i> (3AXD50000027537 [j. ang.]).</p>	
<input type="checkbox"/>	<p>Po wykonaniu tych czynności pierwsze uruchamianie zostanie zakończone i przemiennik częstotliwości będzie gotowy do użycia.</p> <p>Naciśnij przycisk  (Gotowe), aby przejść do widoku głównego.</p>	
<input type="checkbox"/>	<p>Na panelu wyświetlony zostanie widok główny pozwalający na monitorowanie wybranych sygnałów.</p>	

R0-R9



2 — Praca w trybie Hand/Off/Auto

□ Przemiennek częstotliwości może być sterowany zdalnie lub lokalnie. W przypadku sterowania lokalnego dostępne są dwa dodatkowe tryby.



Sterowanie zdalne: Przemiennek częstotliwości jest sterowany przy użyciu interfejsu we/wy lub magistrali komunikacyjnej.

- W górnym wierszu wyświetlana jest informacja Auto.

Sterowanie lokalne: Przemiennek częstotliwości jest sterowany przy użyciu panelu sterowania.

- Gdy górny wiersz zawiera informację Off, oznacza to, że przemiennik częstotliwości jest w trybie Off (wyłączony). Przemiennek częstotliwości jest zatrzymany.

- Gdy górny wiersz zawiera informację Hand, oznacza to, że przemiennik częstotliwości jest w trybie Hand (ręczny). Przemiennek częstotliwości pracuje. Początkowa wartość zadana trybu Hand (ręczny) jest kopiowana z wartości zadanej przemiennika częstotliwości.

Symbol  w górnym wierszu oznacza, że można zmienić wartość zadaną przy użyciu przycisków  i .

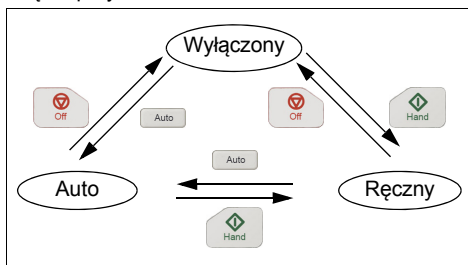

Poniższy rysunek przedstawia zmiany po naciśnięciu przycisku Hand, Off lub Auto:







Uwaga: Jeśli przemiennik częstotliwości zostanie uruchomiony ponownie, gdy błąd 7081 Utrata panelu sterowania jest aktywny, tryb Hand (ręczny) lub Off (wyłączony) zostanie zmieniony na tryb Auto (automatyczny).

Uwaga: Operacja zastąpienia powoduje zastąpienie bieżącego trybu. Patrz dokument *ACH580 firmware manual* (3AXD50000027537 [j. ang.]).

Auto	 ACH580	30.0 Hz
Częstotliwość wyjś... Hz		30.04
◀	Motor current A	0.46 ▶
Motor torque %		9.4
19:29		Menu

Wyt. 	 ACH580	0.0 Hz
Częstotliwość wyjściowa Hz		0.00
◀	Motor current A	0.00 ▶
Motor torque %		0.0
19:23		Menu

Ręczn. 	 ACH580	↕ 30.0 Hz
Częstotliwość wyjś... Hz		30.00
◀	Motor current A	0.45 ▶
Motor torque %		9.4
Wartość za... 19:29		Menu

Wyt. 	 ACH580	0.0 Hz
 Błąd 7081		
Kod pomocniczy: 0000 0000		
Utrata panelu ster. Wto 12.01.		
Błąd utraty panelu sterowania		
Ukryj 14:26		Resetuj

R0-R9



PL

PT – Guia de início rápido









Este guia descreve como inicializar o inversor de frequência utilizando o assistente de inicialização no painel de controle HVAC. Para informações completas sobre inicialização consulte o *ACH580 firmware manual* (3AXD50000027537 [inglês]).

Antes de iniciar

Certifique-se de que o inversor de frequência foi instalado conforme descrito no capítulo *PT – R6...R9 Guia de instalação rápida* na página 105 (carcaças R0...R9).

R0-
R9

Dando início ao assistente de inicialização no painel de controle HVAC

Segurança	
<input type="checkbox"/>	Certifique-se de que a instalação tenha sido concluída. Certifique-se de que a tampa do inversor de frequência e a caixa de cabo, se inclusas, estão em seu devido lugar.
<input type="checkbox"/>	 Verifique se a partida do motor não provoca nenhum perigo. Desacople a máquina que será acionada se houver risco de danos no caso de um sentido de rotação incorreto.
Dicas sobre como utilizar o painel de controle	
<p>Os dois comandos na parte inferior do visor (Options [Opções] e Menu na figura à direita) exibem as funções das duas teclas  e , localizadas abaixo do visor. Os comandos atribuídos às teclas variam dependendo do contexto. Use as teclas , ,  e  para mover o cursor e/ou alterar valores dependendo da visualização ativa. A tecla  exibe uma página de ajuda relacionada ao contexto.</p>	
1 – Configurações do assistente de inicialização: Idioma, valores nominais do motor e data e hora	
<input type="checkbox"/>	<p>Tenha os dados da plaqueta de identificação do motor em mãos.</p> <p>Dê partida no inversor de frequência.</p>

PT

R0-
R9



<p><input type="checkbox"/> O assistente de inicialização o ajudará nessa primeira etapa. O assistente iniciará automaticamente. Espere até que o painel de controle entre na visualização mostrada à direita. Selecione o idioma que deseja utilizar, destacando-o (caso ele ainda não esteja destacado) e pressionando (OK). Observação: Depois de selecionar o idioma, ainda levará alguns minutos para que o painel de controle seja ativado.</p>	
<p><input type="checkbox"/> Selecione Prepare o ACH580 e pressione (Seguinte).</p>	

Consulte a plaqueta de identificação do motor para configurar os valores nominais do motor a seguir. Insira os valores exatamente como consta na plaqueta.

Exemplo de uma plaqueta de identificação de um motor de indução (assíncrono):

3 ~ motor		M2AA 200 MLA 4							
		IEC 200 M/L 55							
No									
				Ins.cl. F		IP 55			
V	Hz	kW	r/min	A	cos φ	I/A	I/N	t	E/s
690 Y	50	30	1475	32.5	0.83				
400 D	50	30	1475	56	0.83				
660 Y	50	30	1470	34	0.83				
380 D	50	30	1470	59	0.83				
415 D	50	30	1475	54	0.83				
440 D	60	35	1770	59	0.83				
Cat. no		3GAA 202 001 - ADA							
6312/C3		6210/C3				180 kg			
IEC 34-1									

PT

<p><input type="checkbox"/> Verifique se os dados do motor estão corretos. Os valores são predefinidos com base no tamanho do inversor de frequência, mas é necessário verificar se eles correspondem ao motor. Comece com a opção tipo do motor.</p> <ul style="list-style-type: none"> Vá para a visualização de edição de uma linha selecionada pressionando . Navegue na visualização com as teclas e . <p>Cosφ nominal do motor e torque nominal são opcionais. Pressione (Seguinte) para continuar.</p>	
--	--

<input type="checkbox"/> Para alterar um valor na visualização de edição: <ul style="list-style-type: none"> • Use e para mover o curso para a esquerda e direita. • Use e para alterar o valor. Pressione (Guardar) para aceitar a nova configuração, ou pressione (Cancelar) para voltar para a visualização anterior sem fazer alterações.	
<input type="checkbox"/> Essa etapa é opcional e requer que o motor esteja em rotação. Não realize essa etapa se ela puder causar riscos ou se a configuração mecânica não permitir. Para fazer o teste de direção, selecione Rodar o motor e pressione (Seguinte)).	
<input type="checkbox"/> Pressione a tecla Hand (Manual) no painel para ligar o inversor de frequência.	
<input type="checkbox"/> Verifique a direção do motor. Se ela estiver na direção de avanço, selecione Sim, o motor está a rodar para a frente e pressione (Seguinte) para continuar. Se a direção não for de avanço, selecione Não, corrigir sentido e pressione (Seguinte) para continuar.	
<input type="checkbox"/> Selecione a localização que você deseja utilizar e pressione (Seguinte).	

R0-R9



PT

R0-
R9

<input type="checkbox"/> <p>Altere as unidades mostradas no painel, se necessário.</p> <ul style="list-style-type: none"> Vá para a visualização de edição de uma linha selecionada pressionando . Navegue na visualização com as teclas e . <p>Vá para a próxima visualização pressionando (Seguinte).</p>	
<input type="checkbox"/> <p>Para selecionar um valor na visualização de edição:</p> <ul style="list-style-type: none"> Use e para selecionar o valor. <p>Pressione (Guardar) para aceitar a nova configuração, ou pressione (Cancelar) para voltar para a visualização anterior sem fazer alterações.</p>	
<input type="checkbox"/> <p>Defina as opções data e hora, bem como seu formato de exibição.</p> <ul style="list-style-type: none"> Vá para a visualização de edição de uma linha selecionada pressionando . Navegue na visualização com as teclas e . <p>Vá para a próxima visualização pressionando (Seguinte).</p>	
<input type="checkbox"/> <p>Para dar um nome ao inversor de frequência que será exibido na parte superior pressione . Caso você não deseje alterar o nome padrão (ACH580), continue, pressionando (Seguinte).</p> <p>Para informações sobre como editar texto, consulte o <i>ACH580 firmware manual</i> (3AXD50000027537 [inglês]).</p>	
<input type="checkbox"/> <p>A primeira inicialização está concluída e o inversor de frequência está pronto para ser usado. Pressione (Feito) para ir para visualização inicial.</p>	

PT

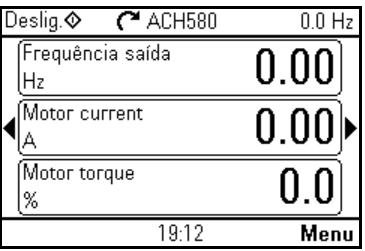
<input type="checkbox"/>	Os valores dos sinais seleccionados monitorados pela visualização inicial são mostrados no painel.	 <p>The screenshot shows a control panel for an ACH580 inverter. At the top, it displays 'Deslig.' with a diamond icon, a refresh icon, 'ACH580', and '0.0 Hz'. Below this are three rows of data: 'Frequência saída Hz' with a value of '0.00', 'Motor current A' with a value of '0.00', and 'Motor torque %' with a value of '0.0'. At the bottom, it shows the time '19:12' and a 'Menu' button.</p>
--------------------------	--	--

R0-
R9

PT

2 – Operação manual/desligada/automática



O inversor de frequência pode estar em controle remoto ou controle local. No controle local há dois modos diferentes adicionais.

Controle remoto: O inversor de frequência é controlado pela E/S ou fieldbus.

- A linha superior da visualização exibe a opção Auto (Automático).

Controle local: O inversor de frequência é controlado pelo painel de controle.

- A linha superior da visualização exibe a opção Off (Desligado), ou seja, o inversor de frequência está no modo desligado. O inversor de frequência está parado.
- A linha superior da visualização exibe a opção Hand (Manual), ou seja, o inversor de frequência está no modo manual. O inversor de frequência está funcionando. A referência inicial no modo manual é copiada da referência do inversor de frequência.

O símbolo  na linha superior indica que você pode alterar a referência com  e .

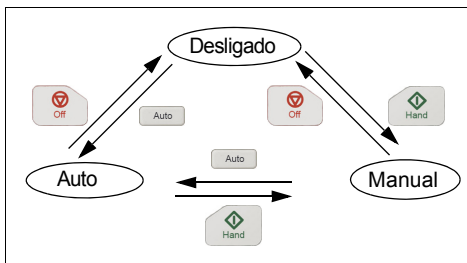

O diagrama a seguir exibe as transições de estado quando você pressiona o botão Hand, Off ou Auto:





Observação: Ao reiniciar o inversor de frequência enquanto a falha 7081 Perda painel estiver ativa, o modo será alterado de Manual ou Desligado para Automático.

Observação: Override operation (Substituir operação) substitui o modo de execução atual. Consulte o *ACH580 firmware manual* (3AXD50000027537 [Inglês]).

Auto	 ACH580	30.0 Hz
Frequência saída		30.04
Hz		
Motor current		0.46
A		
Motor torque		9.4
%		
14:14		Menu

Deslig. 	 ACH580	0.0 Hz
Frequência saída		0.00
Hz		
Motor current		0.00
A		
Motor torque		0.0
%		
19:12		Menu

Man 	 ACH580	 30.0 Hz
Frequência saída		30.00
Hz		
Motor current		0.45
A		
Motor torque		9.4
%		
Referência	14:14	Menu

Deslig. 	 ACH580	0.0 Hz
 Falha 7081		
Cod aux: 0000 0000		
Perda painel		Ter 12.01.
Falha perda painel de controle		
Ocultar	14:13	Rearme

R0-R9



PT

RU – Краткое руководство по вводу в эксплуатацию

В этом руководстве описывается ввод привода в эксплуатацию с помощью помощника первого запуска панели управления HVAC. Полные сведения о вводе в эксплуатацию приведены в документе *ACH580 firmware manual* (код английской версии AXD50000027537).









R0-R9



Подготовительные операции

Убедитесь, что привод установлен так, как описано в главе *RU – Руководство по быстрому монтажу R6...R9* на стр. 115 (типоразмеры R6...R9).

Запуск с помощью мастера первого запуска панели управления HVAC

Техника безопасности	
<input type="checkbox"/>	Убедитесь, что монтажные работы завершены. Убедитесь, что крышки привода и кабельной коробки (если они включены в комплект поставки) находятся на своем месте.
<input type="checkbox"/>	 Убедитесь в том, что пуск двигателя не связан с какой-либо опасностью. Отсоедините приводимый в движение механизм , если существует опасность повреждения оборудования в случае неправильного направления вращения.
Советы по использованию интеллектуальной панели управления	
<p>Две команды в нижней части экрана (Параметры и Меню на рисунке справа) указывают назначение двух функциональных клавиш  и , расположенных ниже экрана. Команды, назначенные функциональным клавишам, зависят от ситуации.</p> <p>Кнопки , ,  и  служат для перемещения курсора и/или изменения значений в зависимости от активного представления.</p> <p>Кнопка  показывает контекстно-зависимую страницу справочной системы.</p>	

RU

1 — значения параметров, задаваемые помощником первого запуска: язык, номинальные параметры двигателя, дата и время

Подготовьте данные паспортной таблички двигателя.
Включите питание привода.

Помощник первого запуска помогает выполнить первый запуск.
Помощник начинает работать автоматически. Дождитесь появления изображения, показанного справа, на экране панели управления.
Выберите требуемый язык, выделив его (если он уже не выбран), и нажмите  (ОК).
Примечание. После выбора языка выход панели управления из режима ожидания занимает некоторое время.





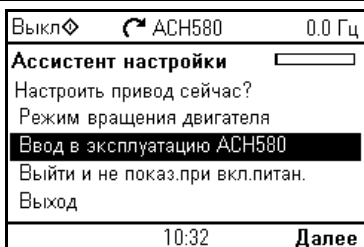



Выберите **Ввод в эксплуатацию АСН580** и нажмите  (Далее).



Чтобы задать следующие номинальные значения, см. данные на паспортной табличке двигателя. Вводимые значения должны точно совпадать с указанными на паспортной табличке двигателя.

Пример паспортной таблички асинхронного двигателя:

		ABB Motors					
3 ~ motor		M2AA 200 MLA 4					
		IEC 200 M/L 55					
		No					
		Ins.cl. F			IP 55		
V	Hz	kW	r/min	A	cos φ	IA/IN	tE/s
690 Y	50	30	1475	32.5	0.83		
400 D	50	30	1475	56	0.83		
660 Y	50	30	1470	34	0.83		
380 D	50	30	1470	59	0.83		
415 D	50	30	1475	54	0.83		
440 D	60	35	1770	59	0.83		
Cat. no		3GAA 202 001 - ADA					
6312/C3				6210/C3		180 kg	
		IEC 34-1					

R0-R9



















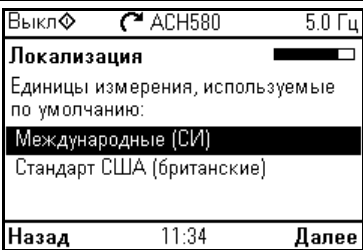



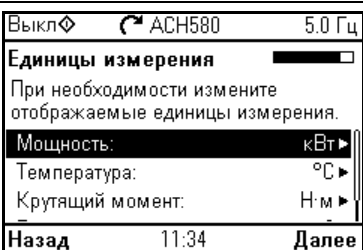





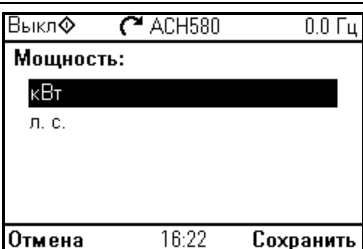

RU

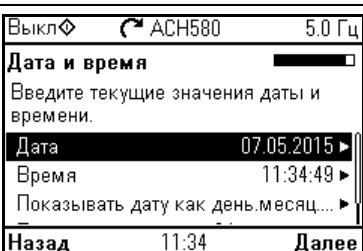

<p>□ Проверьте правильность данных двигателя. Значения предварительно определяются исходя из мощности привода, но необходимо убедиться, что они соответствуют двигателю. Начните с типа двигателя.</p> <ul style="list-style-type: none"> • Для перехода на экран редактирования выбранной строки нажимайте • Для прокрутки изображения используйте стрелки и . <p>Номинальные значения $\cos\Phi$ и крутящего момента двигателя являются дополнительными характеристиками.</p> <p>Для продолжения нажмите (Далее).</p>	
<p>□ Для редактирования изображения:</p> <ul style="list-style-type: none"> • Стрелки и позволяют перемещать курсор влево и вправо. • Для изменения значения используйте стрелки и . <p>Нажмите (Сохранить), чтобы принять новое значение, или (Отмена), чтобы вернуться к предыдущему экрану без внесения изменений.</p>	
<p>□ Эта операция не является обязательной и требует вращения двигателя. Не выполняйте ее, если она сопряжена с какой-либо опасностью или если механическая система не позволяет этого.</p> <p>Чтобы проверить направление вращения, выберите Вращать двигатель и нажмите (Далее).</p>	
<p>□ Нажмите кнопку Hand на панели управления, чтобы запустить привод.</p>	

R0-
R9

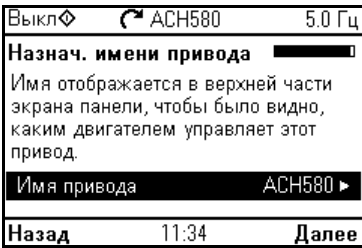
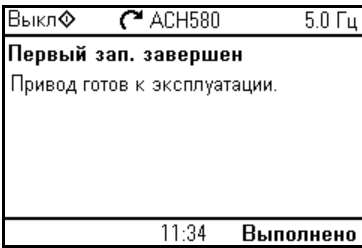

RU

<p>RO-R9</p> 	<p>Проверьте направление вращения двигателя.</p> <p>Если он вращается в прямом направлении, выберите Да, двигатель вращается в прямом направлении и нажмите  (Далее), чтобы продолжить.</p> <p>Если он вращается в обратном направлении, выберите Нет, изменить направление и нажмите  (Далее), чтобы продолжить.</p>	 <p>Ручно  АСН580  5.0 Гц</p> <p>Прямое направление? <input type="checkbox"/></p> <p>После выб. "Нет, изменить напр." привод изм.напр.и новое напр.помечается как "прямое".</p> <p>Да, двиг.вращ. в прямом напр.</p> <p>Нет, изменить направление</p> <p>11:33 Далее</p>
	<p>Выберите систему единиц измерения, которую хотите использовать, и нажмите  (Далее).</p>	 <p>Выкл  АСН580 5.0 Гц</p> <p>Локализация <input type="checkbox"/></p> <p>Единицы измерения, используемые по умолчанию:</p> <p>Международные (СИ)</p> <p>Стандарт США (британские)</p> <p>Назад 11:34 Далее</p>
	<p>Если необходимо, измените единицы измерения, указанные на панели.</p> <ul style="list-style-type: none"> Для перехода на экран редактирования выбранной строки нажимайте . Для просмотра изображения используйте стрелки  и . <p>Переходите к следующему экрану, нажимая  (Далее).</p>	 <p>Выкл  АСН580 5.0 Гц</p> <p>Единицы измерения <input type="checkbox"/></p> <p>При необходимости измените отображаемые единицы измерения.</p> <p>Мощность: кВт </p> <p>Температура: °C </p> <p>Крутящий момент: Н·м </p> <p>Назад 11:34 Далее</p>
<p>RU</p>	<p>Чтобы выбрать значение на экране редактирования:</p> <ul style="list-style-type: none"> Для выбора значения используйте стрелки  и . <p>Нажмите  (Сохранить), чтобы принять новое значение, или  (Отмена), чтобы вернуться к предыдущему экрану без внесения изменений.</p>	 <p>Выкл  АСН580 0.0 Гц</p> <p>Мощность:</p> <p>кВт</p> <p>л. с.</p> <p>Отмена 16:22 Сохранить</p>
	<p>Установите дату и время, а также формат отображения даты и времени.</p> <ul style="list-style-type: none"> Для перехода на экран редактирования выбранной строки нажимайте . Для просмотра изображения используйте стрелки  и . <p>Переходите к следующему экрану, нажимая  (Далее).</p>	 <p>Выкл  АСН580 5.0 Гц</p> <p>Дата и время <input type="checkbox"/></p> <p>Введите текущие значения даты и времени.</p> <p>Дата 07.05.2015 </p> <p>Время 11:34:49 </p> <p>Показывать дату как день.месяц... </p> <p>Назад 11:34 Далее</p>

<input type="checkbox"/>	<p>Чтобы присвоить приводу имя, которое будет отображаться вверху, нажмите стрелку (▶). Если вы не хотите изменять имя, присвоенное по умолчанию (ACH580), нажмите (⏪) (Далее).</p> <p>Сведения о редактировании текста см. в руководстве <i>ACH580 firmware manual</i> (код английской версии 3AXD50000027537).</p>	
<input type="checkbox"/>	<p>Теперь первый запуск выполнен, и привод готов к эксплуатации.</p> <p>Для вызова экрана начального представления нажмите (⏪) (Выполнено).</p>	
<input type="checkbox"/>	<p>На панели отображается экран начального представления, на котором можно контролировать значения выбранных сигналов.</p>	

R0-R9



RU

2 — Работа в местном Hand или автоматическом Auto режимах

□ Привод может работать в режиме дистанционного или местного управления. Режим местного управления, в свою очередь, подразделяется на два различных режима.

Дистанционное управление: управление приводом осуществляется с входов/выходов платы управления или шины Fieldbus.

- В верхней строке экрана отображается «Авто».

Местное управление: управление приводом осуществляется с панели управления.

- В верхней строке экрана отображается «Выкл», что означает, что привод выключен. Привод остановлен.
- В верхней строке экрана отображается «Ручной», что означает, что привод находится в режиме местного управления. Привод работает. Первоначальное задание в режиме местного управления копируется из задания привода.

Символ \blacklozenge в верхней строке означает, что задание можно изменить с помощью стрелок \blacktriangle и \blacktriangledown .

На следующей схеме показан переход состояний при нажатии кнопок Hand, Off и Auto:

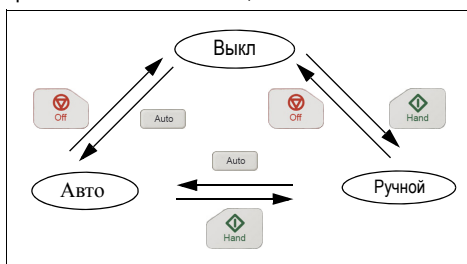

Примечание. Если при перезапуске привода активен отказ 7081 «Control panel loss», режим изменяется с местного управления на выключенный или автоматический.

Примечание. Функция переопределения позволяет изменить текущий режим. См. *ACH580 firmware manual* (3AXD50000027537 [на англ. языке]).

Авто	ACH580	30.0 Hz
Выходная частота Гц	30.04	
Motor current А	0.46	
Motor torque %	9.4	
11:36		Меню

Выкл	ACH580	0.0 Гц
Выходная частота Гц	0.00	
Motor current А	0.00	
Motor torque %	0.0	
11:35		Меню

Ручно	ACH580	30.0 Hz
Выходная частота Гц	30.00	
Motor current А	0.45	
Motor torque %	9.4	
Задание	11:35	Меню

Выкл	ACH580	5.0 Гц
Отказ 7081		
Код AUX: 0000 0000		
Потеря панели	11:35:33	
Ошибка потери связи с панелью управления		
Скрыть	11:35	Сброс

R0-R9



RU

SV – Snabbguide för idrifttagning









I den här guiden beskrivs idrifttagning av frekvensomriktaren med Upstartsassistenten på HVAC-manöverpanelen. Fullständig information om idrifttagning finns i *ACH580 firmware manual* (3AXD5000027537 [engelska]).

Innan du börjar

Se till att frekvensomriktaren har installerats enligt beskrivningen i kapitel [SV – R6...R9 Snabbguide för installation](#) på sidan 125 (byggstorlek R0...R9).

R0-
R9

Idrifttagning med Upstartsassistenten på en HVAC-manöverpanel

Säkerhet	
<input type="checkbox"/>	Säkerställ att installationsarbetet är klart. Säkerställ att frekvensomriktarens kåpa och kabellådan (om den medföljer) är på plats.
<input type="checkbox"/>	 Kontrollera att det inte medför fara om motorn startas. Koppla bort den drivna utrustningen om det finns risk för skada på grund av felaktig rotationsriktning.
Tips för användning av assistentmanöverpanelen	
<p>De två kommandona längst ned på displayen (Alternativ och Meny i figuren till höger), visar funktionerna för de två funktionstangenterna  och  nedanför displayen. Funktionstangenternas funktioner beror på aktuellt sammanhang.</p> <p>Använd tangenterna , ,  och  för att flytta markören och/eller ändra värdena beroende på den aktiva vyn.</p> <p>Tangenten  visar en sammanhangskänslig hjälpsida.</p>	
1 – Inställningar med Upstartsassistenten: Språk, motorns märkvärden samt datum och tid	
<input type="checkbox"/>	Ha motorns märkskyldata till hands. Spänningssätt frekvensomriktaren.

SV

R0-
R9



<input type="checkbox"/> Uppstartsassistenten leder dig genom den första idrifttagningen. Assistenten startar automatiskt. Vänta tills manöverpanelen går in i vyn som visas till höger. Välj det språk du vill använda genom att markera det (om det inte redan är markerat) och trycka på (OK). Obs! När du har valt språk dröjer det några minuter innan manöverpanelen aktiveras.	<div style="border: 1px solid black; padding: 5px;"> English Deutsch Suomi Français Italiano Nederlands Svenska OK ▶ </div>
<input type="checkbox"/> Välj Idrifttagning av ACH580 och tryck på (Nästa).	<div style="border: 1px solid black; padding: 5px;"> Av ◊ ◂ ACH580 0.0 Hz Konfigurationsassistent Vill du konfigurera frekvensomriktaren nu? Roterar motorn Idrifttagning av ACH580 Avsluta och visa inte vid start 14:02 Nästa </div>

Se motors märkskylt för följande motordata. Mata in värdena exakt så som de anges på motors märkskylt.

Exempel på märkskylt på en asynkronmotor:

ABB Motors

3 ~ motor M2AA 200 MLA 4

IEC 200 M/L 55

No

		Ins.cl.		F		IP 55	
V	Hz	kW	r/min	A	cos φ	IA/IN	tE/s
690 Y	50	30	1475	32,5	0.83		
400 D	50	30	1475	56	0.83		
660 Y	50	30	1470	34	0.83		
380 D	50	30	1470	59	0.83		
415 D	50	30	1475	54	0.83		
440 D	60	35	1770	59	0.83		

Cat. no 3GAA 202 001 - ADA

6312/C3		6210/C3	180 kg
---------	--	---------	--------

IEC 34-1















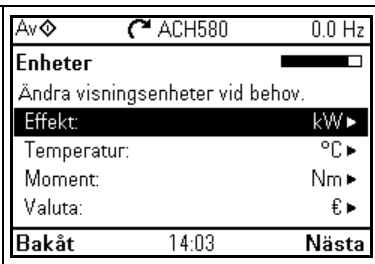

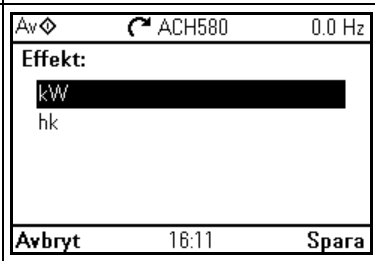

SV

<input type="checkbox"/> Kontrollera att motordata är korrekta. Värdena är fördefinierade baserat på frekvensomriktarens storlek men du bör verifiera att de motsvarar motorn. Starta med motors typ. <ul style="list-style-type: none"> Gå till redigeringsvyn för en markerad rad genom att trycka på . Rulla i vyn med och . Motors nominella cos φ och märkmoment är tillval. Tryck på (Nästa) för att fortsätta.	<div style="border: 1px solid black; padding: 5px;"> Av ◊ ◂ ACH580 0.0 Hz Motorbörvärden Ange värdena, som finns på motors namnplåt, här: Typ: Asynkron motor ▶ Ström: 1.8 A ▶ Spänning: 400.0 V ▶ Bakåt 16:11 Nästa </div>
---	---

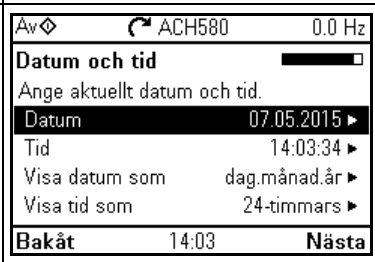
<input type="checkbox"/> Ändra ett värde i en redigeringsvy: <ul style="list-style-type: none"> • Använd och för att flytta markören åt vänster och höger. • Använd och för att ändra värdet. Tryck på (Spara) för att godkänna den nya inställningen eller tryck på (Avbryt) för att gå tillbaka till föregående vy utan att göra ändringar.	
<input type="checkbox"/> Det här steget är valfritt och kräver rotering av motorn. Gör inte detta om det kan orsaka risker eller om den mekaniska konfigurationen inte tillåter det. Gör riktningstestet genom att markera Rotera motorn och trycka på (Nästa).	
<input type="checkbox"/> Tryck på starttangentsen på panelen för att starta frekvensomriktaren.	
<input type="checkbox"/> Kontrollera motorns rotationsriktning. Om den roterar framåt, markera Ja, motorn roterar framåt (om det inte redan är markerat) och tryck på (Nästa) för att fortsätta. Om riktningen inte är framåt, markera Nej, ändra riktning och tryck på (Nästa) för att fortsätta.	
<input type="checkbox"/> Välj lokalisering och tryck på (Nästa).	

R0-
R9

SV

<input type="checkbox"/>	<p>Ändra de enheter som visas på panelen vid behov.</p> <ul style="list-style-type: none"> Gå till redigeringsvy för en markerad rad genom att trycka på . Rulla i vyn med  och . <p>Gå till nästa vy genom att trycka på  (Nästa).</p>	
<input type="checkbox"/>	<p>Välja ett värde i en redigeringsvy:</p> <ul style="list-style-type: none"> Använd  och  för att välja värdet. <p>Tryck på  (Spara) för att godkänna den nya inställningen eller tryck på  (Avbryt) för att gå tillbaka till föregående vy utan att göra ändringar.</p>	
<input type="checkbox"/>	<p>Ange datum och tid och visningsformat för dem.</p> <ul style="list-style-type: none"> Gå till redigeringsvy för en markerad rad genom att trycka på . Rulla i vyn med  och . <p>Gå till nästa vy genom att trycka på  (Nästa).</p>	
<input type="checkbox"/>	<p>Tryck på  för att ange ett namn för frekvensomriktaren som visas längst upp.</p> <p>Om det förvalda namnet inte ska ändras, (ACH580), fortsätt genom att trycka på  (Nästa).</p> <p>Information om redigering av text finns i <i>ACH580 firmware manual</i> (3AXD50000027537 [engelska]).</p>	
<input type="checkbox"/>	<p>Den första starten är klar och frekvensomriktaren är klar att användas.</p> <p>Tryck på  (Klart) för att öppna startvyn.</p>	

R0-R9

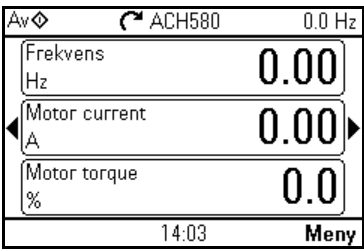

SV

<input type="checkbox"/>	Startvyns förvalda signaler visas på panelen.	 <p>The screenshot shows a control panel for an ACH580 motor. At the top, it displays 'Av' with a diamond icon, a refresh icon, 'ACH580', and '0.0 Hz'. Below this are three rows of data: 'Frekvens Hz' with a value of '0.00', 'Motor current A' with a value of '0.00', and 'Motor torque %' with a value of '0.0'. At the bottom, it shows the time '14:03' and a 'Meny' button.</p>
--------------------------	---	--

R0-
R9

SV

2 – Hand/av/auto

- Frekvensomriktaren kan fjärrstyras eller styras lokalt. I lokal styrning finns det ytterligare två olika lägen.

Fjärrstyrning: Frekvensomriktaren styrs från I/O eller fältbussen.

- Den översta raden i vyn visar Auto.

Lokal styrning: Frekvensomriktare styrs från manöverpanelen.

- Den översta raden i vyn visar Av, dvs. frekvensomriktaren är i avstängt läge. Drivsystemet står stilla.
- Den översta raden i vyn visar Hand, dvs. frekvensomriktaren är i drift. Den första referensen i handläge kopieras från frekvensomriktarens referens. Symbolen \blacklozenge på den översta raden indikerar att referensen kan ändras med \blacktriangle och \blacktriangledown .

Följande schema visar statusövergångar när knappen Hand, Off eller Auto trycks på:

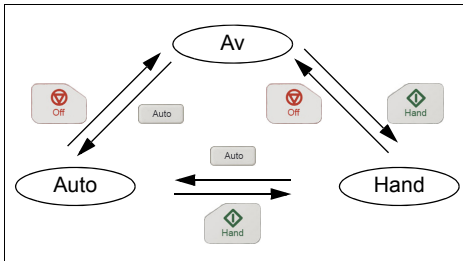

Obs! Om frekvensomriktaren startas om när fel 7081 Panelförlust är aktivt ändras läget från Hand eller Av till Auto.

Obs! Med Override operation åsidosätts det faktiska driftläget. Se *ACH580 firmware manual* (3AXD50000027537 [engelska]).

Auto	ACH580	30.0 Hz
Frekvens Hz	30.04	
Motor current A	0.46	
Motor torque %	9.4	
19:05		Meny

Av \blacklozenge	ACH580	0.0 Hz
Frekvens Hz	0.00	
Motor current A	0.00	
Motor torque %	0.0	
14:03		Meny

Hand \blacklozenge	ACH580	\blacklozenge 30.0 Hz
Frekvens Hz	30.00	
Motor current A	0.45	
Motor torque %	9.4	
Referens	19:05	Meny

Av \blacklozenge	ACH580	0.0 Hz
Fel 7081		
Hjälpkod: 0000 0000		
Panelförlust	07.05.2015	
Bortfall manöverpanel		
Dölj	19:04	Återställ

R0-R9



SV

TR – Hızlı başlatma kılavuzu











Bu kılavuz, HVAC kontrol panelindeki İlk başlatma asistanını kullanarak sürücüyü başlatmayı açıklar. Başlatma hakkında tam bilgi için, bkz. *ACH580 firmware manual* (3AXD5000027537 [İngilizce]).

Başlamadan önce

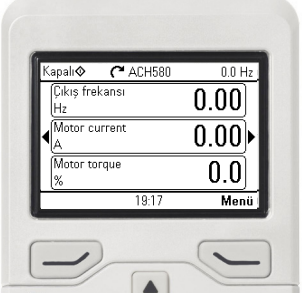

Sürücünün *TR – R6...R9 Hızlı kurulum kılavuzu* bölümü 135. sayfada (R6...R9 kasaları) açıklandığı gibi kurulduğundan emin olun.

R0-
R9

HVAC kontrol panelinde İlk başlatma asistanıyla başlatma





Güvenlik	
<input type="checkbox"/>	Kurulum çalışmasının tamamlandığından emin olun. Sürücünün kapağının ve dahil olması halinde kablo kutusunun takılı olduğundan emin olun.
<input type="checkbox"/>	 Motoru start etmenin bir tehlikeye yol açmayacağından emin olun. Hatalı dönüş yönü durumunda hasar riski varsa motor ile makine arasındaki bağlantıyı sökün.
Asistan kontrol panelini kullanma hakkında ipuçları	
<p>Ekranın alt kısmında iki komut bulunur (sağdaki şekilde Seçenekler ve Menü) ve ekranın alt kısmında ( ile ) iki programlanabilir tuşun fonksiyonunu gösterir. Programlanabilir tuşlara atanan komutlar bağlama göre değişiklik gösterir. İmleci hareket ettirmek ve/veya etkin görünümüne göre değerleri değiştirmek için , ,  ve  tuşlarını kullanın.</p> <p> tuşu içeriğe duyarlı bir yardım sayfası gösterir.</p>	
1 – İlk start asistanı yönlendirmeli ayarlar: Dil, motor nominal değerleri, tarih ve saat	
<input type="checkbox"/>	Motor plakası verilerini yakında tutun. Sürücüye güç verin.
<input type="checkbox"/>	İlk start asistanı ilk başlatma sırasında sizi yönlendirir. Asistan otomatik olarak başlar. Sağda gösterilen kontrol paneli görünümüne girene kadar bekleyin. Kullanmak istediğiniz dili vurgulayarak (zaten vurgulanmamışsa) ve  (Tamam) tuşuna basarak seçin.
	<p>Not: Dili seçtikten sonra, kontrol panelinin uyanması bir kaç dakika sürer.</p> 





TR









<input type="checkbox"/> ACH580'i devreye al öğesini seçin ve  (İleri) tuşuna basın.	Kapalı  ACH580 0.0 Hz
	Kurulum Asistanı Sürücü kurulumu şimdi yapılınsın mı? Motoru döndürme modu ACH580'i devreye al Çık ve çalıştırma sırasında gösterme Çıkış 19:16 İleri

























Aşağıdaki motor nominal değer ayarları için motor plakasına bakın. Değerleri **tam olarak** motor plakasında gösterildiği gibi girin.

Bir endüksiyon (asenron) motoru plakası örneği:

		ABB Motors					
3 ~ motor		M2AA 200 MLA 4		IEC 200 M/L 55			
		No		Ins.cl. F		IP 55	
V	Hz	kW	r/min	A	cos φ	IA/IN	tE/s
690 Y	50	30	1475	32.5	0.83		
400 D	50	30	1475	56	0.83		
660 Y	50	30	1470	34	0.83		
380 D	50	30	1470	59	0.83		
415 D	50	30	1475	54	0.83		
440 D	60	35	1770	59	0.83		
Cat. no		3GAA 202 001 - ADA					
6312/C3		6210/C3		180 kg			
		IEC 34-1					

<input type="checkbox"/> Motor verilerinin doğru olduğunu kontrol edin. Değerler sürücü boyutuna göre önceden tanımlanır, ama motora karşılık geldiklerini siz doğrulamalısınız. Motor tipiyle başlayın. <ul style="list-style-type: none">  tuşuna basarak seçili satırın düzenleme görünümüne gidin.  ve  tuşlarına basarak görünümü kaydırın. Motor nominal cosφ değeri ve nominal moment isteğe bağlıdır. Devam etmek için  (İleri) tuşuna basın.	Kapalı  ACH580 0.0 Hz
	Motor nominal değerleri Motor bilgi plakasındaki değerleri bulun ve bu değerleri buraya girin: Tür: Asenkron motor Akım: 1.8 A Gerilim: 400.0 V Geri 16:16 İleri









<input type="checkbox"/> Düzenleme ekranında bir değer değiştirmek için: <ul style="list-style-type: none"> İmleci sola ve sağa kaydırmak için  ve  tuşlarını kullanın. Değeri değiştirmek için  ve  tuşlarını kullanın. Yeni ayarı kabul etmek için  (Kaydet) tuşuna basın veya değişiklik yapmadan önceki görünümüne geri dönmek için  (İptal) tuşuna basın.	Kapalı  ACH580 0.0 Hz
	Akım: <div style="text-align: center; font-size: 2em; font-weight: bold;">1.8 A</div> <div style="text-align: center;">  </div> İptal 19:16 Kaydet

<input type="checkbox"/>	<p>Bu adım isteğe bağlıdır ve motorun dönmesini gerektirir. Risk oluşturacaksa veya mekanik kurulum buna izin vermiyorsa bunu yapmayın.</p> <p>Yön testini yapmak için, Motoru döndür ögesini seçin ve  (İleri) tuşuna basın.</p>	<p>Kapalı  ACH580 0.0 Hz</p> <p>Yön testi yapılınsın mı? </p> <p>Yön kontrolü için motor döndürülsün mü?</p> <p>Motoru döndür</p> <p>Şimdi değil</p> <p>Geri 19:16 İleri</p>
<input type="checkbox"/>	<p>Sürücüyü başlatmak için paneldeki  Hand tuşuna basın.</p>	<p>Kapalı  ACH580 5.0 Hz</p> <p>El işaretine basın </p> <p>Uyarı: Kurulum tamamlanana kadar, güvenlik cihazları etkin durumda olmaz ve motor hızı 5 Hz olur.</p> <p>Motoru döndürmek için El işaretine basın ve ardından dönüş yönünü</p> <p>Geri 19:16</p>
<input type="checkbox"/>	<p>Motorun yönünü kontrol edin.</p> <p>İleri yöndeyseniz, Evet, motor ileri yönde dönüyor ögesini seçin ve devam etmek için  (İleri) tuşuna basın.</p> <p>İleri yönde değilse, Hayır, yönü düzelt ögesini seçin ve devam etmek için  (İleri) tuşuna basın.</p>	<p>El  ACH580  5.0 Hz</p> <p>Bu ileri mi? </p> <p>“Hayır, yönü düzelt” seçimi sürücünün yönü değiştirmesini ve etiketlerin yeni yön “ileri” olarak değiştirilmesini belirtir.</p> <p>Evet, motor ileri yönde dönüyor</p> <p>Hayır yönü düzelt</p> <p>19:17 İleri</p>
<input type="checkbox"/>	<p>Kullanmak istediğiniz yerelleştirmeyi seçin ve  (İleri) tuşuna basın.</p>	<p>Kapalı  ACH580 0.0 Hz</p> <p>Lokalizasyon </p> <p>Birim varsayılanları:</p> <p>Uluslararası (SI)</p> <p>ABD standardı (İngiliz ölçü birimi)</p> <p>Geri 19:17 İleri</p>
<input type="checkbox"/>	<p>Panelde gösterilen birimleri gerektiğinde değiştirin.</p> <ul style="list-style-type: none">  tuşuna basarak seçili satırın düzenleme görünümüne gidin.  ve  tuşlarına basarak görünümü kaydırın. <p>Sonraki görünüme gitmek için  (İleri) tuşuna basın.</p>	<p>Kapalı  ACH580 0.0 Hz</p> <p>Birimler </p> <p>Gerekirse ekran birimlerini değiştirin.</p> <p>Güç: kW </p> <p>Sıcaklık: °C </p> <p>Tork: Nm </p> <p>Para birimi: € </p> <p>Geri 19:17 İleri</p>

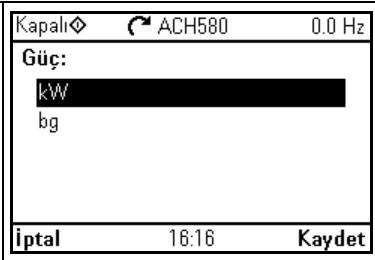
R0-R9

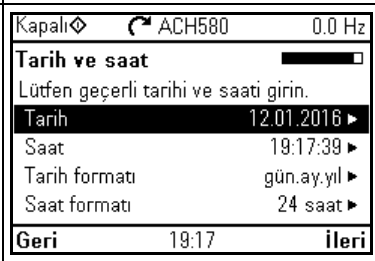

TR

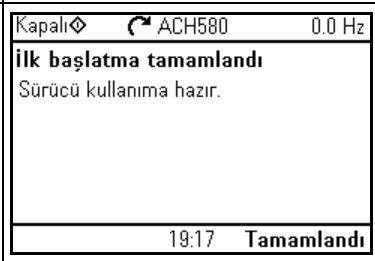
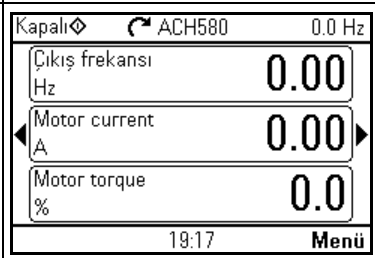
<input type="checkbox"/>	<p>Düzenleme görünümünde bir değeri seçmek için:</p> <ul style="list-style-type: none"> Değeri değiştirmek için ▲ ve ▼ tuşlarını kullanın. <p>Yeni ayarı kabul etmek için  (Kaydet) tuşuna basın veya değişiklik yapmadan önceki görünüme geri dönmek için  (İptal) tuşuna basın.</p>	
<input type="checkbox"/>	<p>Tarih ve saatin yanı sıra tarih ve saat görüntüleme biçimlerini de ayarlayın.</p> <ul style="list-style-type: none">  tuşuna basarak seçili satırın düzenleme görünümüne gidin. ▲ ve ▼ tuşlarına basarak görünümü kaydırın. <p>Sonraki görünüme gitmek için  (İleri) tuşuna basın.</p>	
<input type="checkbox"/>	<p>Sürücüyü üstte gösterilecek bir ad vermek için,  tuşuna basın.</p> <p>Varsayılan adı (ACH580) değiştirmek istemiyorsanız,  (İleri) tuşuna basarak devam edin.</p> <p>Metni düzenleme hakkında bilgi için, bkz. <i>ACH580 firmware manual</i> (3AXD50000027537 [İngilizce]).</p>	
<input type="checkbox"/>	<p>İlk başlatma artık tamamlanmıştır ve sürücü kullanıma hazırdır.</p> <p>Ana görünüme girmek için  (Tamamlandı) tuşuna basın.</p>	
<input type="checkbox"/>	<p>Seçilen sinyallerin değerlerini izleyen Home görünümü panelde gösterilir.</p>	

R0-R9



TR

2 – Manuel/Kapalı/Otomatik çalışma



☐ Sürücü uzaktan kontrolde veya lokal kontrolde olabilir ve lokal kontrolde ek olarak iki farklı mod vardır.

Uzaktan kontrol: Sürücü G/Ç veya fieldbus üzerinden kontrol edilir.

- Görünümün üst satırında Oto. gösterilir.

Lokal kontrol: Sürücü kontrol paneli üzerinden kontrol edilir.

- Görünümün üst satırında Kapalı gösterilir, yani sürücü Kapalı modundadır. Sürücü durduruldu.
- Görünümün üst satırında El gösterilir, yani sürücü El modundadır. Sürücü çalışıyor. El modundaki başlangıç referansı sürücü referansından kopyalanır.

En üst satırdaki  sembolü, referansı  ve  ile değiştirebileceğinizi belirtir.

Aşağıdaki şema Hand, Off veya Auto düğmesine bastığınızdaki durum geçişlerini gösterir:

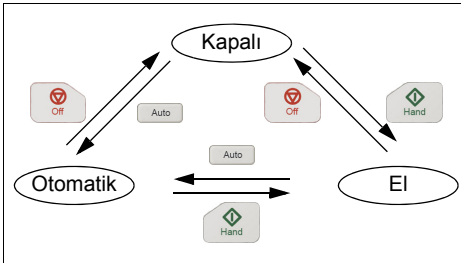

Not: Sürücüyü 7081 Control panel loss hatası etkinken yeniden start ederseniz, mod El veya Kapalı modundan Otomatik moduna geçer.

Not: Geçersiz kılma işlemi gerçek çalışma modunu geçersiz kılar. Bkz. *ACH580 firmware manual* (3AXD50000027537 [İngilizce]).

Oto.  ACH580 30.0 Hz

Çıkış frekansı
Hz 30.04

Motor current
A 0.46

Motor torque
% 9.4

14:19 Menü

Kapalı   ACH580 0.0 Hz

Çıkış frekansı
Hz 0.00

Motor current
A 0.00

Motor torque
% 0.0

19:17 Menü

El   ACH580  30.0 Hz

Çıkış frekansı
Hz 30.00

Motor current
A 0.45

Motor torque
% 9.4

Referans 14:19 Menü

Kapalı   ACH580 0.0 Hz

 Arıza 7081

YARDIMCI kod: 0000 0000

Kntrl paneli kaybı Sal.12.01.

Kumanda paneli kaybı hatası

Gizle 14:19 Sıfırla

R0-
R9



TR

R0-
R9



TR

ZH – 快速启动指南











本指南介绍如何在 HVAC 控制盘上使用“首次启动助手”启动变频器。如需了解有关启动的完整信息，请参阅 *ACH580 firmware manual* (3AXD50000027537 [英语])。

启动之前

确保按照第 145 页的 *ZH – R6...R9 快速安装指南* 一章（外形尺寸 R0...R6）。

在 HVAC 控制盘上用“初次启动助手”启动

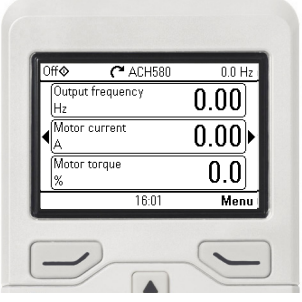
R0-
R9

安全	
<input type="checkbox"/>	确保安装工作已经完成。确保变频器的盖板和电缆盒位置就位。
<input type="checkbox"/>	 检查确保电机的启动不造成任何危险。如果由于不正确的转动方向可能导致损坏， 请将被驱动的机器断开。
使用助手型控制盘的提示	
<p>显示屏底部的两个命令（右图的选项和菜单）显示了屏幕下方的两个软键  和  的功能。分配给软键的命令在不同上下文环境中会有所不同。用 , ,  和  键移动光标和 / 或根据当前视图修改值。</p> <p> 键会显示一个上下文相关的帮助页面。</p>	
1 – 首次启动助手引导的设置： 语言、电机额定值以及日期和时间	
<input type="checkbox"/>	请准备好电机铭牌数据。 给变频器上电。
<p><input type="checkbox"/> “首次启动助手”会引导您完成首次启动。助手会自动开始运行。等待控制盘进入如右图所示的画面。</p> <p>选择您想使用的语言（如果尚未选中），然后按  (OK)。</p> <p>注：选择了语言后，控制盘需要几分钟时间来激活。</p>	

ZH

R0-R9



<input type="checkbox"/> 选择 调试 ACH580 并按 (下一步)。	<div style="border: 1px solid black; padding: 5px;"> <div style="display: flex; justify-content: space-between; border-bottom: 1px solid black;"> Off ACH580 0.0 Hz </div> <p>Set-up Assistant</p> <p>Set up drive now? <input type="checkbox"/></p> <p>Spin the motor mode</p> <p>Commission the ACH580</p> <p>Exit & don't show at power-up</p> <p>Exit</p> <div style="display: flex; justify-content: space-between; border-top: 1px solid black; border-bottom: 1px solid black;"> 01:15 Next </div> </div>
--	---

电机的下列额定值设置请参考电机铭牌。完全按照电机铭牌所示输入值。

感应（异步）电机铭牌示例：

ABB Motors

3 ~ motor M2AA 200 MLA 4

IEC 200 M/L 55

No

		Ins.cl.		F		IP 55	
V	Hz	kW	r/min	A	cos φ	I _A /I _N	t/s
690 Y	50	30	1475	32.5	0.83		
400 D	50	30	1475	56	0.83		
660 Y	50	30	1470	34	0.83		
380 D	50	30	1470	59	0.83		
415 D	50	30	1475	54	0.83		
440 D	60	35	1770	59	0.83		

Cat. no 3GAA 202 001 - ADA











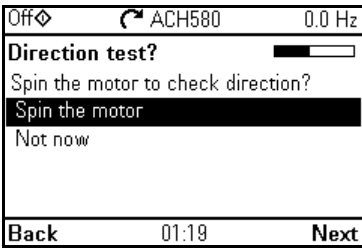

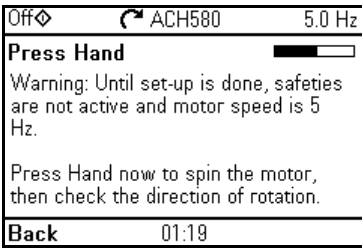





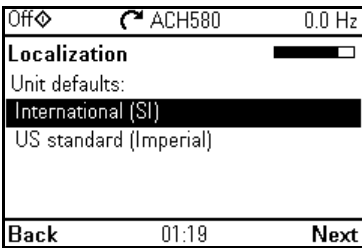

6312/C3		6210/C3	180 kg
---------	--	---------	--------

IEC 34-1

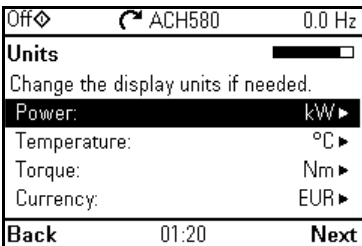
<input type="checkbox"/> 检查确认电机数据正确。这些值是根据变频器规格预先定义的，但是您应该确认它们与电机对应。 从输入电机类型开始。 <ul style="list-style-type: none"> • 按 进入所选行的编辑视图。 • 用 和 滚动视图。 电机额定 cos φ 和额定转矩是选填项目。 按 (下一步) 继续。	<div style="border: 1px solid black; padding: 5px;"> <div style="display: flex; justify-content: space-between; border-bottom: 1px solid black;"> Off ACH580 0.0 Hz </div> <p>Motor nominal values</p> <p>Find the values on the motor's nameplate, and enter them here:</p> <p>Type: Asynchronous motor </p> <p>Current: 1.8 A </p> <p>Voltage: 400.0 V </p> <div style="display: flex; justify-content: space-between; border-top: 1px solid black; border-bottom: 1px solid black;"> Back 01:17 Next </div> </div>
--	--

<input type="checkbox"/> 要在编辑视图上更改一个值： <ul style="list-style-type: none"> • 用 和 左右移动光标。 • 用 和 修改数值。 按 (保存) 接受新设置，或按 (取消) 来返回原先视图而不做任何修改。	<div style="border: 1px solid black; padding: 5px;"> <div style="display: flex; justify-content: space-between; border-bottom: 1px solid black;"> Off ACH580 0.0 Hz </div> <p>Current:</p> <p style="font-size: 2em; text-align: center;">1.8 A</p> <div style="text-align: center; margin-top: 10px;"> </div> <div style="display: flex; justify-content: space-between; border-top: 1px solid black; border-bottom: 1px solid black;"> 0.0 5.2 </div> <div style="display: flex; justify-content: space-between; border-bottom: 1px solid black;"> Cancel 01:18 Save </div> </div>
--	--

ZH

□	<p>此步骤是可选的，要求转动电机。如果这可能会导致任何风险或者机械设置不允许此动作，请勿执行此操作。</p> <p>要执行方向测试，选择转动电机并按  (下一步)。</p>	 <p>Off  ACH580 0.0 Hz</p> <p>Direction test?</p> <p>Spin the motor to check direction?</p> <p>Spin the motor</p> <p>Not now</p> <p>Back 01:19 Next</p>
□	<p>在控制盘上按手形键 ，启动变频器。</p>	 <p>Off  ACH580 5.0 Hz</p> <p>Press Hand</p> <p>Warning: Until set-up is done, safeties are not active and motor speed is 5 Hz.</p> <p>Press Hand now to spin the motor, then check the direction of rotation.</p> <p>Back 01:19</p>
□	<p>检查电机的转动方向。</p> <p>如果是正向，选择是的，电机正在正向旋转并按  (下一步) 继续。</p> <p>如果不是正向，选择不，修改方向并按  (下一步) 继续。</p>	 <p>Hand  ACH580 5.0 Hz</p> <p>Is this forward?</p> <p>Selecting "No, fix direction" tells the drive to change direction, and labels the new direction "forward".</p> <p>Yes, motor is spinning forward</p> <p>No, fix direction</p> <p>01:19 Next</p>
□	<p>选择希望使用的单位并按  (下一步)。</p>	 <p>Off  ACH580 0.0 Hz</p> <p>Localization</p> <p>Unit defaults:</p> <p>International (SI)</p> <p>US standard (Imperial)</p> <p>Back 01:19 Next</p>
□	<p>如有必要，修改面板上显示的单位。</p> <ul style="list-style-type: none"> 按  进入所选行的编辑视图。 用  和  滚动视图。 <p>按  (下一步) 进入下一个视图。</p>	 <p>Off  ACH580 0.0 Hz</p> <p>Units</p> <p>Change the display units if needed.</p> <p>Power: kW </p> <p>Temperature: °C </p> <p>Torque: Nm </p> <p>Currency: EUR </p> <p>Back 01:20 Next</p>

R0-R9



ZH

<p>□</p>	<p>要在编辑视图上选择一个值：</p> <ul style="list-style-type: none"> 用 和 选择值。 <p>按 (保存) 接受新设置，或按 (取消) 来返回原先视图而不做任何修改。</p>	
<p>□</p>	<p>设置日期和时间以及日期时间显示格式。</p> <ul style="list-style-type: none"> 按 进入所选行的编辑视图。 用 和 滚动视图。 <p>按 (下一步) 进入下一个视图。</p>	
<p>□</p>	<p>要给变频器命名（显示在顶部），按 。</p> <p>如果您不想改变默认名称 (ACH580)，按 (下一步) 继续。</p> <p>有关编辑文字的更多信息，请参阅 <i>ACH580 firmware manual</i> (3AXD50000027537 [英语])。</p>	
<p>□</p>	<p>首次启动到此完成，变频器已经可以使用了。</p> <p>按 (完成) 进入主页视图。</p>	
<p>□</p>	<p>主页视图会显示面板上显示的所选信号的值。</p>	

R0-
R9

ZH

2 - 手动 / 关闭 / 自动运行

扁平器可以通过远程控制或本地控制，在本地控制中，又有两种不同的模式。

远程控制：从 I/O 或现场总线控制变频器。

- 视图的顶行显示 Auto。

本地控制：从控制盘控制变频器。

- 视图顶行显示 Off，也就是说，变频器处于关闭模式。变频器停止运行。
- 视图顶行显示 Hand，也就是说，变频器处于手动模式。变频器运行中。Hand 模式中的初始参照值复制自变频器的参照值。
顶行的符号 \blacklozenge 表示您可以用 \blacktriangle 和 \blacktriangledown 修改参照值。

下列图表显示了当您按下 Hand、Off 或 Auto 按钮时的状态变化。

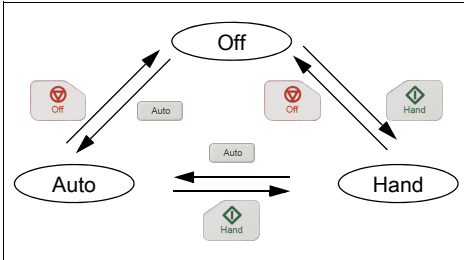

注：当您在故障 7081 控制盘丢失状态下重新启动变频器时，模式从 Hand 或 Off 变为 Auto。

注：覆盖操作会覆盖实际的运行模式。请参阅 *ACH580 firmware manual (3AXD5000002753 [英语])*。

Auto	ACH580	30.0 Hz
Output frequency	Hz	30.04
Motor current	A	0.46
Motor torque	%	9.4
	16:00	Menu

Off \blacklozenge	ACH580	0.0 Hz
Output frequency	Hz	0.00
Motor current	A	0.00
Motor torque	%	0.0
	16:01	Menu

Hand \blacklozenge	ACH580	30.0 Hz
Output frequency	Hz	30.00
Motor current	A	0.45
Motor torque	%	9.4
Reference	16:00	Menu

Off \blacklozenge	ACH580	0.0 Hz
Fault 7081	Aux code: 0000 0000	
Control panel loss	16:18:35	
Control panel loss fault		
Hide	16:54	Reset

R0-R9



R0-
R9



Contact us

3AXD50000036602 Rev A (MUL) 2016-03-11



3AXD50000036602A